

The Raptor 3" Setback Bracket can be installed directly to either the port or starboard transom of the boat.

Item / Assembly	Part #	Description	Qty.
2	2352802	SETBACK BRACKET, PAINTED	1
	2352803	SETBACK BRKT, PAINTED WHT *white*	1
▲	2354912	INSTRC-INSTALL,SETBACK BRK	1
A Items 4 - 10	2994940	BAG ASM,SETBACK HDW,RPTR	1
4	2371758	WASHER-3/8 HD FLAT SS	4
6	2353102	NUT-3/8-16 FLANGE,NYLOK,SS	4
8	2383422	SCREW-3/8-16 X 1 1/4 HHCS SS	4
10	2378608	ANTI SEIZE TUBE, 4CC	1

* This part is included in an assembly and cannot be ordered individually.

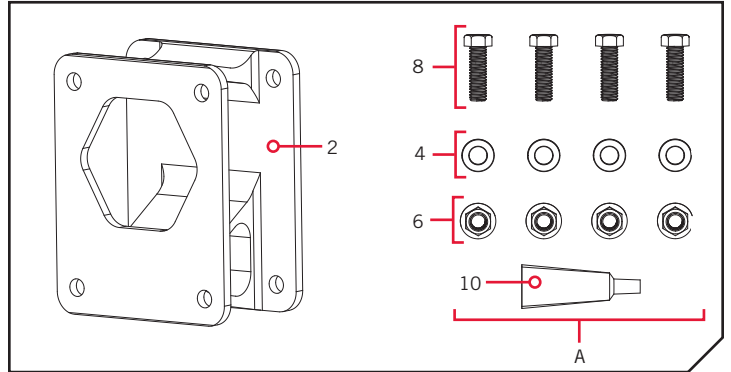

▲ Not shown on Parts Diagram.

NOTICE: Use the 3" Setback Bracket (1810370 and 1810375 - white) when 3" of additional setback is needed. May be mounted directly to the transom or added to a 4" or 6" Jack Plate bracket for either a Port or Starboard installation. The Setback Bracket may also be paired with the Raptor Direct Mount Angle Bracket (1810371 and 1810376 - white) for additional mounting options.

TOOLS AND RESOURCES REQUIRED

- Drill
- 9/16" Box End or Socket Wrench
- Marine Grade Sealant
- 20ft/lb capacity Torque Wrench
- Awl or similar marking tool
- A second person to help with installation
- Masking Tape
- 7/16" Drill Bit
- File, sand paper, or emery board
- 9/16" Open End Wrench

MOUNTING CONSIDERATIONS

Complete Typical Installation

The Raptor 3" Setback Bracket can be used to mount the Raptor in a variety of ways. This includes:

1. Directly to the Transom of the boat, with the Raptor Built-in Mounting Bracket mounted to the 3" Setback Bracket.
2. Between the Raptor Direct Mount Angle Bracket and the Built-in Raptor Mounting Bracket.
3. Between any one of the Raptor Jack Plate brackets and the Raptor Built-in Mounting Bracket.

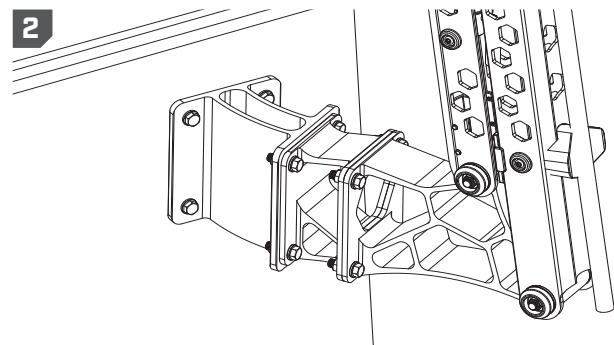
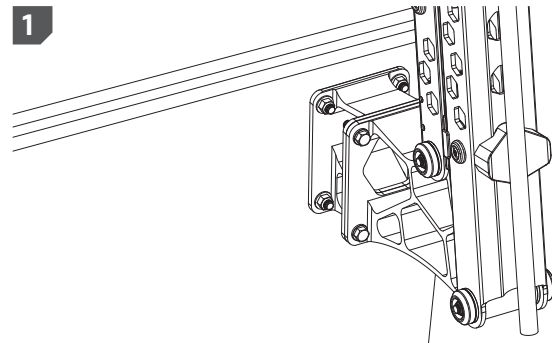
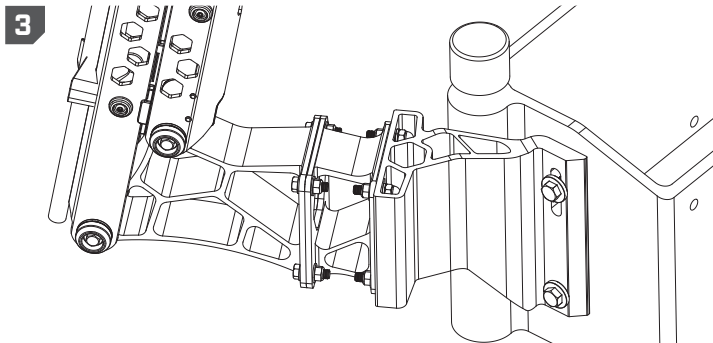

Mounting Considerations

Before mounting your Raptor 3" Setback Bracket to the boat, please give consideration to the following:

1. Unobstructed Mounting - When selecting the mounting location, examine your boat to ensure that you will not drill into any obstructions and that the hardware will be accessible for assembly.

2. Unobstructed Deployment and Retraction - The Raptor is designed to mount on either the port or starboard side of the transom. The Raptor must have a clear, unobstructed path to deploy. Check to make sure that your proposed location will allow the anchor to deploy and retract without hitting trim tabs, poling platforms, ladders, the engine or other obstructions. You should also consider your fishing methods when selecting the mounting location.

3. Raptor to Hull Clearance - The bottom edge of the Raptor should never be less than 4" above the hull directly below the Raptor to prevent spray and drag conditions. This applies to any bracket mounting configuration used.

4. Raptor to Engine Clearance - When selecting a mounting location, make sure that no interference exists between the Raptor and your engine during normal operation. Once you have selected your mounting location, trim the engine all the way up and all the way down, and steer the engine fully to the left and right to confirm proper engine clearance. Ensure there is a minimum of two to three inches of clearance from any point on the Raptor in all states of stow and deploy.

5. Hexagon Cutout - When mounted on either the Port or Starboard side, the bracket should always be oriented to with the hexagon cutout facing away from the transom. When mounting the Setback Bracket with additional Raptor mounting brackets, the Hexagon Cutout should always face towards the Built-in Raptor Mounting Bracket.

NOTICE: These installation steps switch between mounting options and may differ from your actual installation.

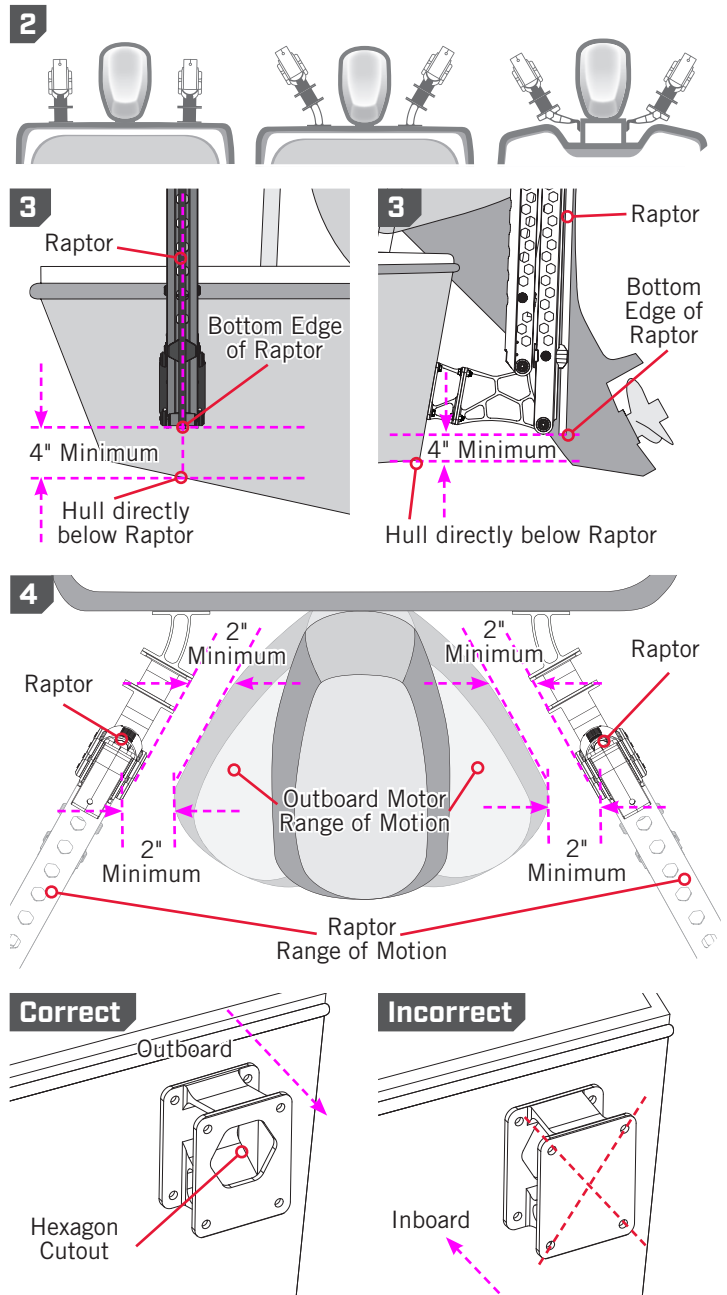

Installing the 3" Setback Bracket Directly to the Transom

1

ITEM(S) NEEDED

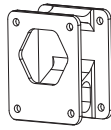

#2 x 1

- a. Review the Mounting Considerations to determine if it is acceptable to complete a direct mount of the Raptor 3" Setback Bracket. If acceptable, position the 3" Setback Bracket (Item #2) at the selected location. Make sure that the Hexagon Cutout is positioned away from the Transom and facing Outboard. With the bracket level and in place, mark all four Mounting Holes with a pen or similar marking tool.

NOTICE: It is recommended to have a second person help with installation.

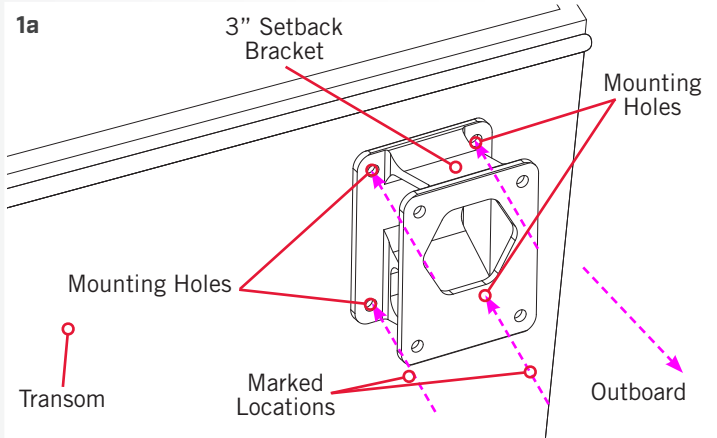

2

- b. Double check that the mounting location is clear to drill holes and then use a Drill with a 7/16" Drill Bit to drill through the Transom/Stern of the boat on the marked locations.

NOTICE: When drilling holes into fiberglass, it is helpful to first cover the surface with masking tape. This will help keep the boat surface unmarked and help with cleanup. Cover the surface and then mark the location to drill. Once the holes are drilled, remove the masking tape before continuing installation.

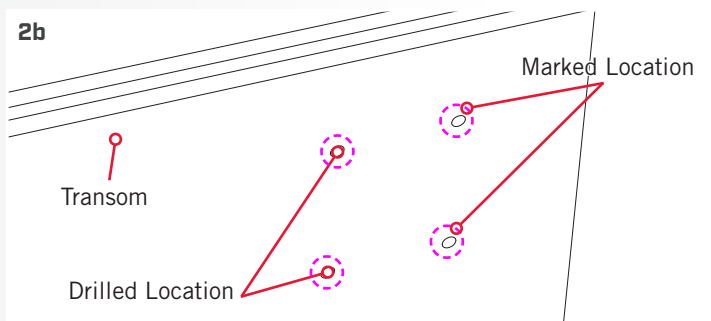

NOTICE: When drilling the marked holes, make sure that the drill bit is perpendicular to the Transom/Stern of the boat and that the holes are being drilled straight. Not drilling the holes straight will give the mounting hardware a poor fit.

3

- c. Place a 1/8" bead of Marine Grade Sealant on the Transom of the boat around the drilled holes.
- d. Place the Marine Grade Sealant around the Mounting Holes on the face of the 3" Setback Bracket that will contact the boat Transom/Stern when mounted. This should be the face of the bracket without the Hexagon Cutout. Keep the sealant approximately centered between the outside edge of the Mounting Bracket and the Mounting Holes. Once the sealant is in place, align the 3" Setback Bracket in the desired orientation with the holes that were drilled in the Transom/Stern.

NOTICE: To install the 3" Setback Bracket to the boat, the Hardware Kit (Assembly 2994943) included with the Raptor will be needed. This includes Four (Part #2371758) Flat Washers, Four (Part #2371759) Stainless Steel Fender Washers, Four (Part #2383421) 3/8 - 16 X 3 1/2 Stainless Steel Hex Head Cap Screws, Four (Part #2353102) Stainless Steel Nylock Flange Nuts and anti-seize.

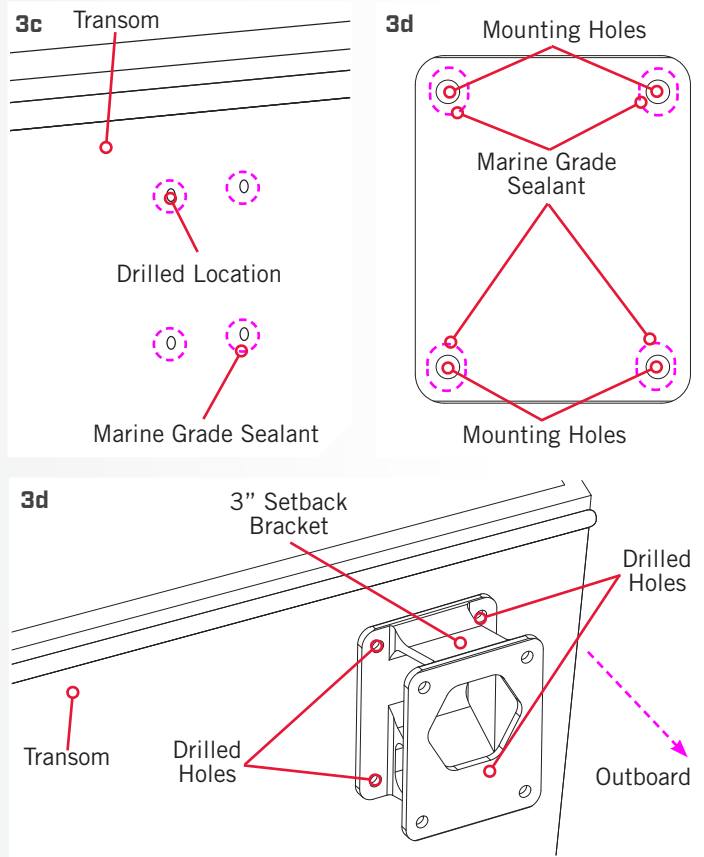

4

ITEM(S) NEEDED



- e. To install the 3" Setback Bracket to the Transom, use the Mounting Hardware Kit 2994943 provided with the Raptor. Take each of the four 3-1/2" Stainless Steel Hex Head Cap Screws (Part #2383421) and place one Fender Washer (Part #2371759) on them. Apply anti-seize (Item #10) to the hardware. The Hex Head Cap Screws will pass through the Drilled Holes on the Transom, passing from inboard to outboard. Once through the Drilled Holes in the Transom, they will pass into the Mounting Holes on the 3" Setback Bracket.
- f. Place a Flat Washer (Part #2371758) on the end of each screw on the Outboard side of the 3" Setback Bracket and then secure each with a Flange Nut (Part #2353102). Apply anti-seize to the threads before tightening. Tighten the screws with a 9/16" Box End or Socket Wrench. Do not over-tighten. Tighten to 20 ft-lbs.

NOTICE: To prevent seizing of the stainless steel hardware, do not use high speed installation tools. Applying an anti-seize may help prevent seizing.

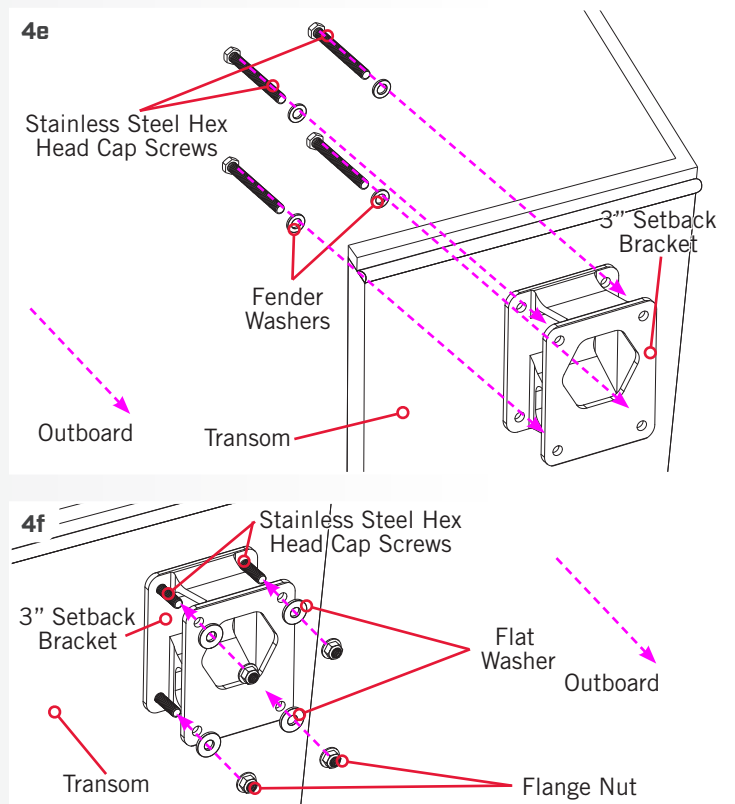

5

ITEM(S) NEEDED

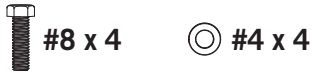

- g. With the 3" Setback Bracket secured to the Transom, take the Raptor and align the Built-in Mounting Bracket with the Mounting Holes on the 3" Setback Bracket.
- h. With the help of a second person, hold the Raptor in place to install the mounting hardware. Take the four 1-1/4" Stainless Steel Hex Head Cap Screws (Item #8) and four of the Stainless Steel Flat Washers (Item #4). Place a Washer on the end of each screw and then apply Anti-seize to the threads of each Screw. Insert each screw with washer into the Raptor Built-in Mounting Bracket and then into the 3" Setback Bracket.

NOTICE: To prevent seizing of the stainless steel hardware, do not use high speed installation tools. Applying an anti-seize may help prevent seizing.

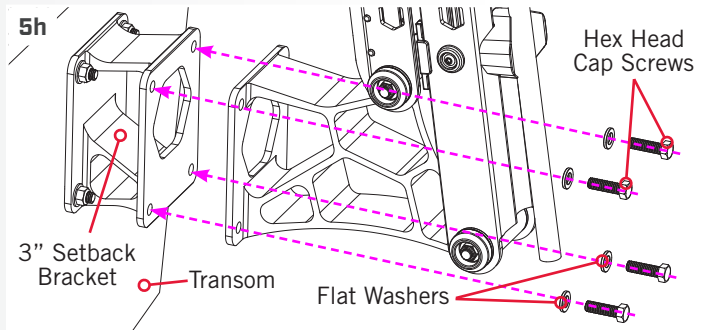
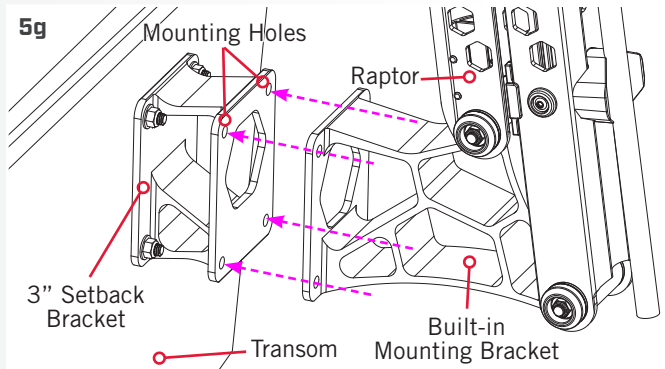

6

ITEM(S) NEEDED



- i. Take four of the Flange Nuts (Item #6) and place one on the end of each of the Hex Head Cap Screws.
- j. Apply anti-seize to the threads before tightening. Once set, tighten the Flange Nuts with a 9/16" Box End or Socket Wrench. Do not over-tighten. Tighten to 20 ft-lbs.

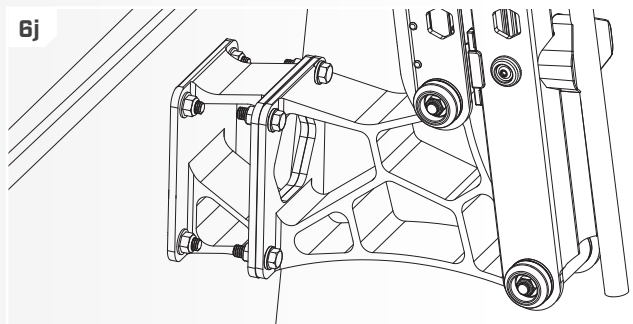
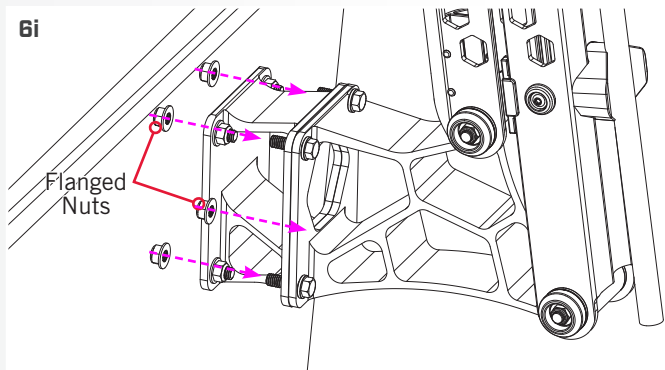

Installing the 3" Setback Bracket to the Direct Mount Angle Bracket

1

- a. Review the Mounting Considerations to determine if it is acceptable to complete a mount of the Raptor 3" Setback Bracket to the Direct Mount Angle Bracket. Begin with the Direct Mount Angle Bracket already installed to the boat. For specific instructions, please refer to the Installation Instructions included with the Direct Mount Angle Bracket (1810371 or 1810376 - white). Once the Direct Mount Angle Bracket is secured to the boat, continue below.

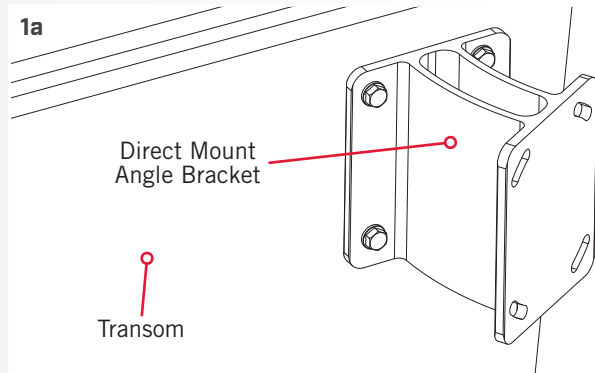

NOTICE: To install the 3" Setback Bracket to the Direct Mount Angle Bracket, the Hardware Kit (Assembly 2994940) included with the Raptor Direct Mount Angle Bracket will be needed. This includes Four (Part #2383422) Stainless Steel Hex Head Cap Screws, Four (Part #2371758) Stainless Steel Flat Washers, Four (Part #2353102) Stainless Steel Nylock Flange Nuts and Anti-seize (Part #2378608).

2

ITEM(S) NEEDED

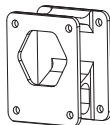

#2 x 1

- b. Take the 3" Setback Bracket (Item #2) and the Raptor with the Built-in Mount Bracket and align them so that the Hexagon Cutout on the Setback Bracket is facing towards the Raptor.

NOTICE: It is recommended to have a second person help with installation.

NOTICE: On the final installation, the 3" Setback Bracket will be installed to the Direct Mount Angle Bracket with the Hexagon Cutout facing Outboard.

2b

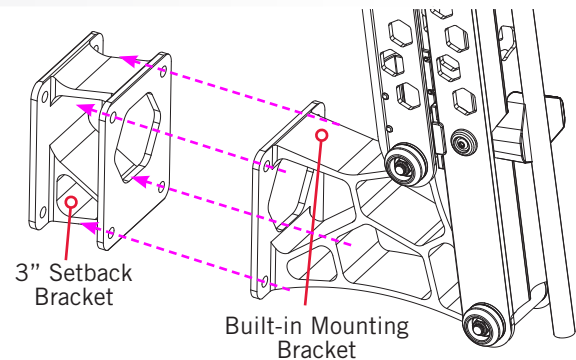

3

ITEM(S) NEEDED



#8 x 4

⊙ #4 x 4



#10 x 1

- c. Take the four 1-1/4 Stainless Steel Hex Head Cap Screws (Item #8) and four of the Stainless Steel Flat Washers (Item #4). Place a Washer on the end of each Screw and then apply Anti-seize (Item #10) to the threads of each Screw. Insert each screw with washer into the Raptor Built-in Mounting Bracket and then into the 3" Setback Bracket.

NOTICE: To prevent seizing of the stainless steel hardware, do not use high speed installation tools. Applying an anti-seize may help prevent seizing.

3c

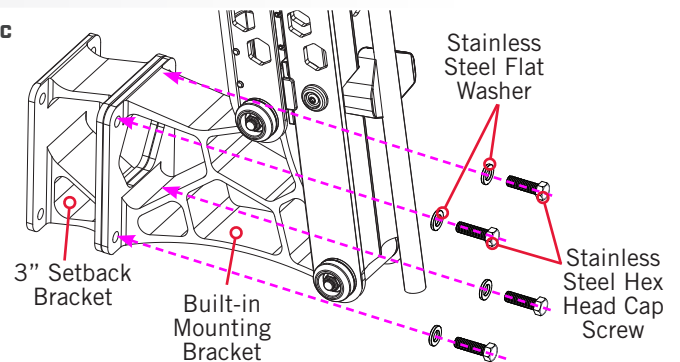

4

ITEM(S) NEEDED

⊙ #6 x 4

- d. Take four of the Flange Nuts (Item #6) and place one on the end of each of the Hex Head Cap Screws.
- e. Apply anti-seize to the threads before tightening. Once set, tighten the Flange Nuts with a 9/16" Box End or Socket Wrench. Do not over-tighten. Tighten to 20 ft-lbs.

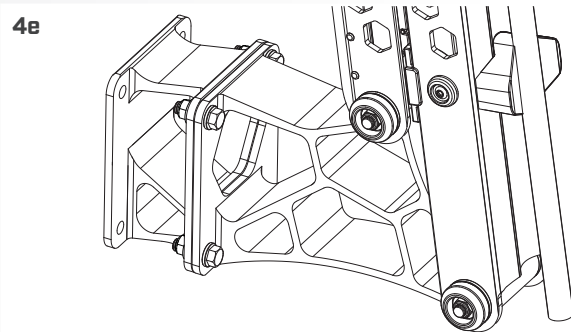
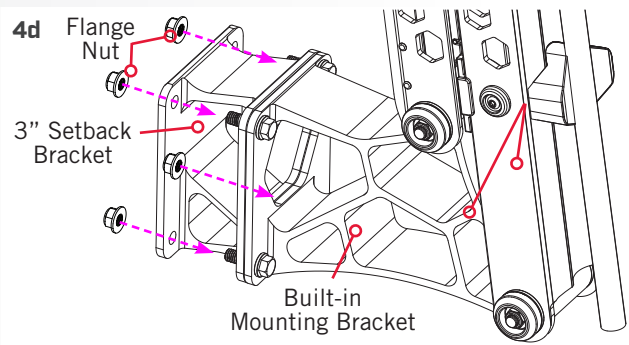

5

- f. With the help of a second person, position the 3" Setback Bracket, that was just secured to the Raptor, so that the Slotted Holes on the Direct Mount Angle Bracket align with the Mounting Holes in the 3" Setback Bracket. Notice that the holes are slotted on the angle bracket so that the Raptor can be adjusted along the slots for the final installation.

NOTICE: It is recommended to have a second person help with installation.

- g. To install the 3" Setback Bracket to the Direct Mount Angle Bracket, the Hardware Kit (Assembly 2994940) included with the Raptor Direct Mount Angle Bracket will be needed. Take the Four (Part #2383422) Stainless Steel Hex Head Cap Screws and Four (Part #2371758) Stainless Steel Flat Washers from this kit. Place a Washer on the end of each Screw and then apply Anti-seize to the threads of each Screw. Insert each Screw into the 3" Setback Bracket and then into the Slotted Holes of the Direct Mount Angle Bracket.

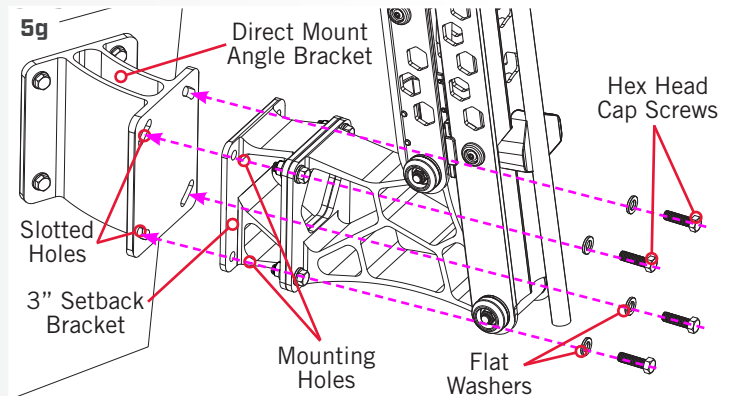
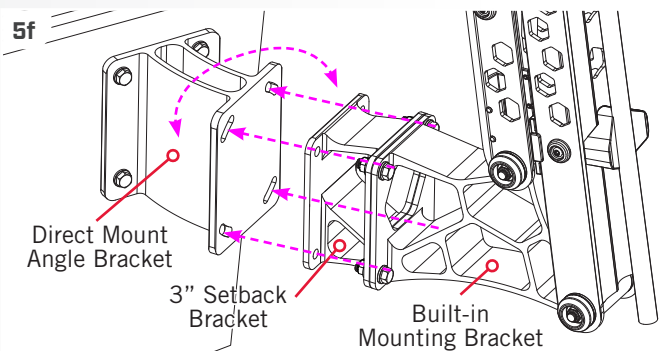

6

- h. Take four of the Flange Nuts and place one on the end of each of the Hex Head Cap Screws. Secure them loosely.
- i. Then check the angle of the bracket along the Slotted Holes and confirm that the Raptor is set at the desired angle along the holes. Apply anti-seize to the threads before tightening. Once set, tighten the Flange Nuts with a 9/16" Box End or Socket Wrench. Do not over-tighten. Tighten to 20 ft-lbs.

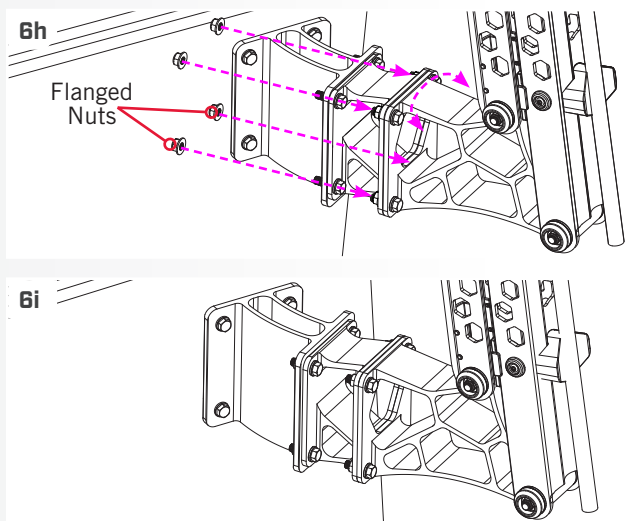

Installing the 3" Setback Bracket to a Jack Plate Bracket

1

- a. Review the Mounting Considerations to determine if it is acceptable to complete a mount of the Raptor 3" Setback Bracket to a Raptor Jack Plate Bracket. Begin with any one of the Raptor Jack Plate Brackets already installed to the boat. For specific instructions, please refer to the Installation Instructions included with the Jack Plate Brackets. Once the Jack Plate Bracket is secured to the boat, Leave the hardware and red retainer in place until instructed to remove it and continue below.

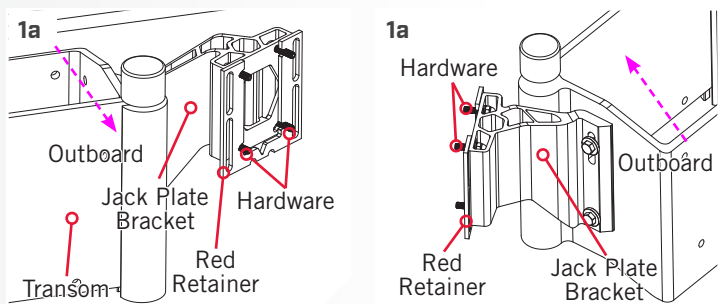

NOTICE: Raptor Jack Plate options include a Port bracket with either a 4" (1810361 and 1810366 - white) or 6" (1810363 and 1810368 - white) rise or a Starboard bracket with either a 4" (1810360 and 1810365 - white) or 6" (1810362 and 1810367 - white) rise.

NOTICE: To install the 3" Setback Bracket to the Direct Mount Angle Bracket, pieces from the Hardware Kit (Assembly 2994939) included with the Raptor Jack Plate Brackets will be needed. Pieces needed include (Part #2353102) Stainless Steel Nylock Flange Nuts and Anti-seize (Part #2378608).

2

ITEM(S) NEEDED

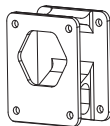

#2 x 1

- b. Take the 3" Setback Bracket (Item #2) and the Raptor with the Built-in Mount Bracket and align them so that the Hexagon Cutout on the Setback Bracket is facing towards the Raptor.

NOTICE: On the final installation, the 3" Setback Bracket will be installed to the Direct Mount Angle Bracket with the Hexagon Cutout facing Outboard.

NOTICE: It is recommended to have a second person help with installation.

2b

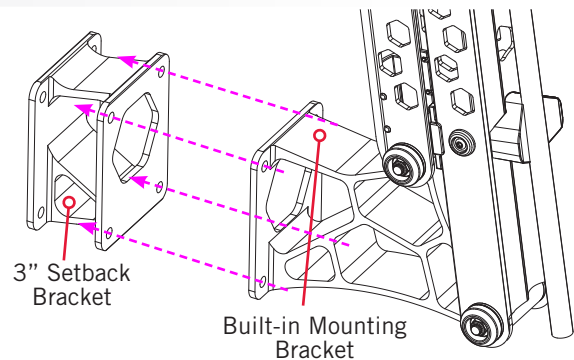

3

ITEM(S) NEEDED



#8 x 4

⊙ #4 x 4



#10 x 1

- c. Take the four 1-1/4 Stainless Steel Hex Head Cap Screws (Item #8) and four of the Stainless Steel Flat Washers (Item #4). Place a Washer on the end of each Screw and then apply Anti-seize (Item #10) to the threads of each Screw. Insert each screw with washer into the Raptor Built-in Mounting Bracket and then into the 3" Setback Bracket.

NOTICE: To prevent seizing of the stainless steel hardware, do not use high speed installation tools. Applying an anti-seize may help prevent seizing.

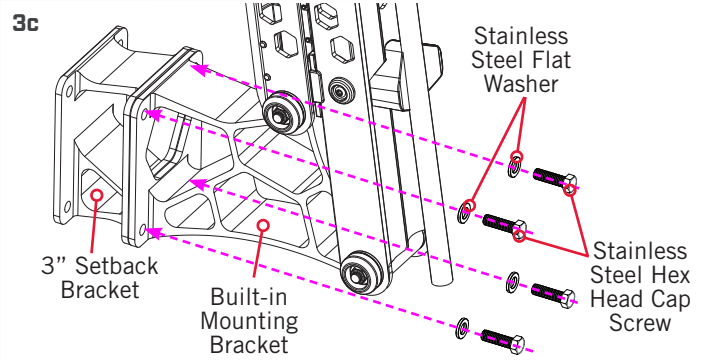

4

ITEM(S) NEEDED

⊙ #6 x 4

- d. Take four of the Flange Nuts (Item #6) and place one on the end of each of the Hex Head Cap Screws.
- e. Apply anti-seize to the threads before tightening. Once set, tighten the Flange Nuts with a 9/16" Box End or Socket Wrench. Do not over-tighten. Tighten to 20 ft-lbs.

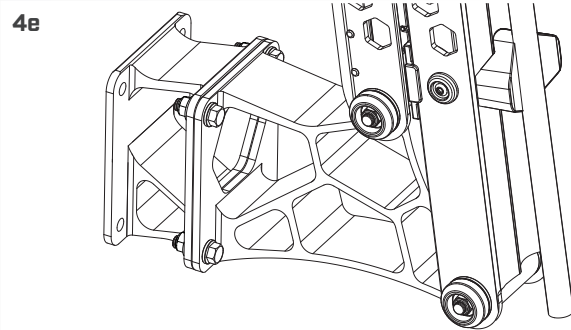
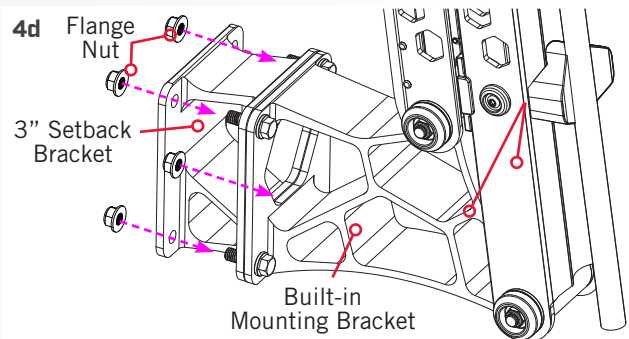

5

- f. With the help of a second person, position the 3" Setback Bracket, that was just secured to the Raptor, so that the hardware in the Red Retainer on the Jack Plate bracket aligns with the Mounting Holes in the 3" Setback Bracket.

NOTICE: The Red Retainer helps to align the hardware in the Jack Plate Bracket with the Mounting Holes in the 3" Setback Bracket to aid in installation. Keep the Red Retainer in place until instructed to remove it.

NOTICE: It is recommended to have a second person help with installation.

- g. To install the 3" Setback Bracket to the Jack Plate bracket, the four Stainless Steel Flange Nuts (Part #2353201) and Anti-seize (Part #2378608) from the Mounting Assembly 2994939, from any one of the Raptor Jack Plate Bracket will be needed. Apply Anti-seize to the threads of the hardware held in place by the Red Retainer. Then install the 3" Setback Bracket to the hardware. Take four of the Flange Nuts and place one on the end of each of the Hex Head Cap Screws. Secure them loosely.

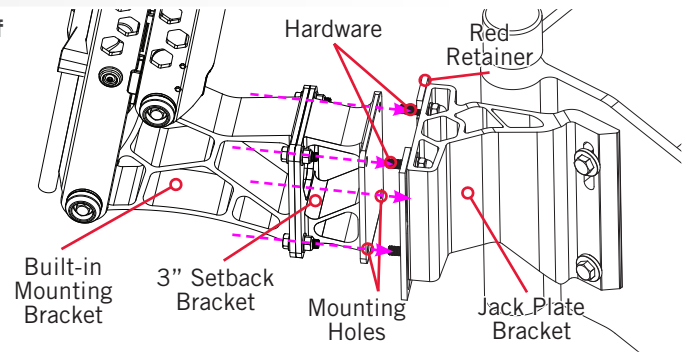
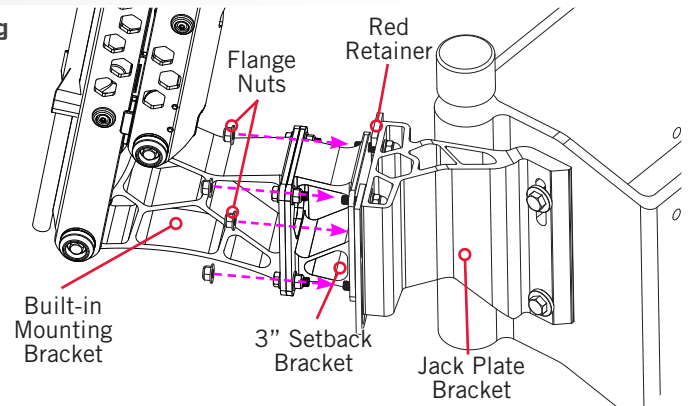
5f**5g****6**

- h. With the Flange Nuts in place, pull the Red Retainer out to release the hardware. There are handles on each side of the Red Retainer that can be used to grasp each half. When pulling the Red Retainer, grasp each side and pull so that the Red Retainer breaks at the center and releases the hardware.

NOTICE: The Mounting Holes on the Jack Plate are slotted so that the Raptor can be adjusted along the slots for the final installation.

- i. With the Red Retainer removed, there is slack in the mounting hardware between the Jack Plate Bracket and 3" Setback Bracket. This allows the brackets to be rotated for final Raptor placement along the Slotted Holes in the Jack Plate Bracket. Check the angle of the bracket along the Slotted Holes and confirm that the Raptor is set at the desired angle. Once set, hold the hardware inside the Jack Plate Bracket with a 9/16" Open End Wrench. Tighten the Flange Nuts with a 9/16" Box End or Socket Wrench. Do not over-tighten. Tighten to 20 ft-lbs.

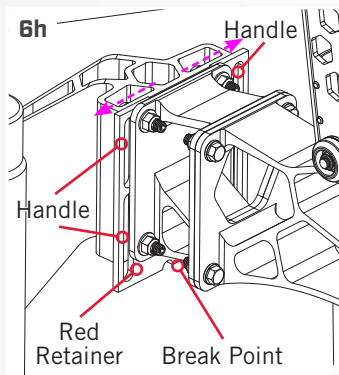
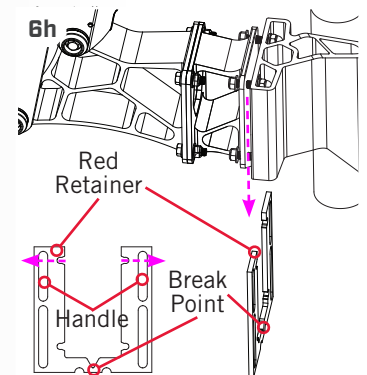
6h**6h****6i**