

PRECISION ONBOARD CHARGERS

**MK 106PCL, MK 212PCL, MK 318PCL, MK 110PCL,
MK 220PCL, MK 330PCL, MK 440PCL & MK 550PCL**

Owner's Manual

INTRODUCTION

THANK YOU

Thank you for choosing Minn Kota®. We believe that you should spend more time fishing and less time positioning your boat. That's why we build the smartest, toughest, most intuitive marine products on the water. Every aspect of a Minn Kota product is thought out and rethought until it's good enough to bear our name. Countless hours of research and testing provide you the advantages of a Minn Kota product that can truly take you "Anywhere. Anytime". We don't believe in shortcuts. We are Minn Kota. And we are never done helping you catch more fish.

REGISTRATION

Remember to keep your receipt and immediately register your charger. To receive all the benefits of your product warranty, please fill out and mail the registration card.

SERIAL NUMBER

Your Minn Kota 11-character serial number is very important. It helps to determine the specific model and year of manufacture. When contacting Consumer Service or registering your product, you will need to know your product's serial number. We recommend that you write the serial number down so that you have it available for future reference.

NOTICE: The serial number on your Precision Charger is located on the bottom of the charger and on the Warning Decal on the AC Power Cord.

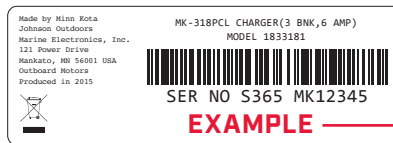
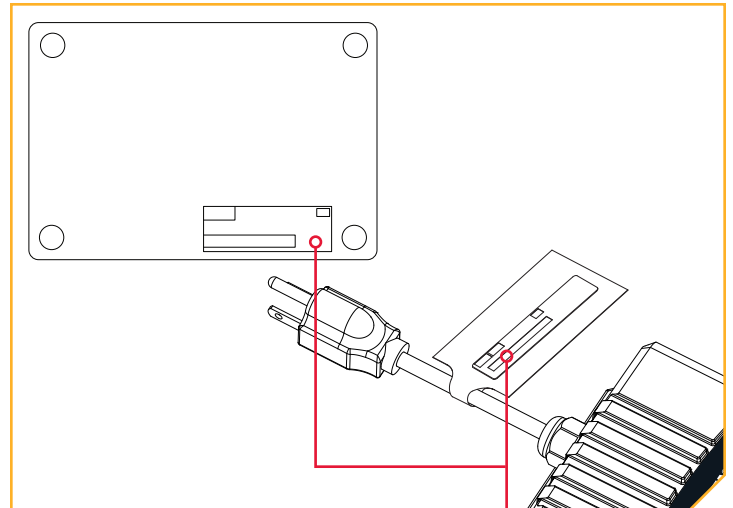

SAFETY INSTRUCTIONS

IMPORTANT SAFETY INSTRUCTIONS - SAVE THESE INSTRUCTIONS

1. **SAVE THESE INSTRUCTIONS** - This manual contains important safety and operating instructions for your Minn Kota battery charger. The Minn Kota battery charger is a powerful electrical device. If incorrectly installed, configured or operated, the battery charger can damage batteries and / or electrical equipment. Please thoroughly read the instructions and safety information contained in this manual before operating the battery charger.
2. Use of an attachment not recommended or sold by Johnson Outdoors Marine Electronics, Inc. may result in a risk or fire, electric shock, or injury to persons.
3. To reduce the risk of damage to electric plug and cord, pull by plug rather than cord when disconnecting charger.
4. An extension cord should not be used unless absolutely necessary. Use of improper extension cord could result in a risk of fire and electric shock. If an extension cord must be used, make sure:
 - a) That pins on plug of extension cord are the same number, size and shape as those of plug on charger;
 - b) That extension cord is properly wired and in good electrical condition; and
 - c) That wire size is large enough for ac ampere rating of charger as specified in table.

Model	AWG Size		
	25' AC Extension Cord	50' AC Extension Cord	100' AC Extension Cord
MK 106PCL	18 AWG	18 AWG	16 AWG
MK 212PCL	18 AWG	18 AWG	16 AWG
MK 318PCL	16 AWG	16 AWG	12 AWG
MK 110PCL	18 AWG	18 AWG	16 AWG
MK 220PCL	16 AWG	16 AWG	12 AWG
MK 330PCL	16 AWG	16 AWG	12 AWG
MK 440PCL	16 AWG	12 AWG	10 AWG
MK 550PCL	14 AWG	12 AWG	10 AWG

5. Do not operate charger with damaged cord or plug.
6. Do not operate charger if it has received a sharp blow, been dropped, or otherwise damaged in any way. Do not operate charger with damaged cord or plug – replace the charger immediately.
7. Do not disassemble charger.
8. To reduce risk of electric shock, unplug charger from outlet and disconnect from battery before attempting any maintenance or cleaning. Turning off controls will not reduce this risk.

WARNING

9. WARNING - RISK OF EXPLOSIVE GASES

- a) **WORKING IN VICINITY OF A LEAD-ACID BATTERY IS DANGEROUS. BATTERIES GENERATE EXPLOSIVE GASES DURING NORMAL BATTERY OPERATION. FOR THIS REASON, IT IS OF UTMOST IMPORTANCE THAT YOU FOLLOW THE INSTRUCTIONS EACH TIME YOU USE THE CHARGER.**
- b) To reduce the risk of battery explosion, follow these instructions and those published by the battery manufacturer and manufacturer of any equipment you intend to use in the vicinity of the battery. Review cautionary markings on these products and on engine.

SAFETY INSTRUCTIONS



10. External connections to the charger shall comply with the United States Coast Guard Electrical Regulation (33CFR183, SUB PART 1). For safety and compliance reasons, we recommend that you follow American Boat and Yacht Council (ABYC) standards when rigging your boat. Altering boat wiring should be completed by a qualified marine technician.

11. PERSONAL PRECAUTIONS

- a) Consider having someone close enough by to come to your aid when you work near a lead-acid battery.
- b) Have plenty of fresh water and soap nearby in case acid contacts skin, clothing, or eyes.
- c) Wear complete eye protection and clothing protection. Avoid touching eyes while working near battery.
- d) If battery acid contacts skin or clothing, wash immediately with soap and water. If acid enters eyes, immediately flood eye with running cold water for at least 10 minutes and get medical attention immediately.
- e) NEVER smoke or allow a spark or flame in vicinity of battery or engine.
- f) Be extra cautious to reduce risk of dropping a metal tool onto battery. It might spark or short-circuit battery or other electrical part that may cause explosion.
- g) Remove personal metal items such as rings, bracelets, necklaces, and watches when working with a lead-acid battery. A lead-acid battery can produce a short-circuit current high enough to weld a ring or the like to metal, causing a severe burn.
- h) Use charger for charging batteries only. It is not intended to supply power to a low voltage electrical system other than in a starter-motor application. Do not use battery charger for charging dry-cell batteries that are commonly used with home appliances. These batteries may burst and cause injury to persons and damage to property.
- i) NEVER charge a frozen battery.

12. PREPARING TO CHARGE

- a) If necessary to remove battery from boat or vehicle to charge, always remove grounded terminal from battery first. Make sure all accessories in the boat or vehicle are off, so as not to cause an arc.
- b) Be sure area around battery is well ventilated while battery is being charged.
- c) Clean battery terminals. Be careful to keep corrosion from coming in contact with eyes.
- d) Add distilled water to each cell until battery acid reaches level specified by battery manufacturer. Do not overfill. For a battery without removable cell caps, such as valve regulated lead acid batteries, carefully follow manufacturer's recharging instructions.
- e) Study all battery manufacturer's specific precautions while charging and recommended rates of charge.
- f) The Minn Kota charger will only charge 12 Volt/6 Cell Lead-acid Batteries (Flooded, Maintenance Free, or AGM) and 12 Volt Lithium (LiFePO₄) Batteries (check battery manufacturer's specifications). Do not connect the output of the charger to any other voltage or battery type.

13. CHARGER LOCATION

- a) Locate charger as far away from battery as dc cables permit.
- b) Never place charger directly above battery being charged; gases from battery will corrode and damage charger.
- c) Never allow battery acid to drip on charger when reading electrolyte specific gravity or filling battery.
- d) Do not operate charger in a closed-in area or restrict ventilation in any way.
- e) Do not set a battery on top of charger.



SAFETY INSTRUCTIONS



- f) Do not mount the charger below the waterline of the boat or directly adjacent to fuel tanks.
- g) Each DC output cord is six feet long. Make sure that all DC output cords can reach the batteries and that the AC power cord can reach a power source. When using an extension cord, make the AC connection to the charger outside of the battery compartment as far away as practical to reduce the risk of a spark igniting gases in the compartment.
- h) Do not shorten the DC output cords, as this can affect charger output.
- i) If the DC output cords are not long enough, they may be lengthened by splicing and soldering 12 AWG (minimum) wire. Each splice should be covered with dual wall adhesive-lined heat shrink tubing to protect the joint from corroding. The splice should be made between the fork in the output cable and the fuse holder. The fuse holder should always remain within 7" of the battery terminals. The maximum extension length is 15 feet. You may contact the Minn Kota Service Department with any questions.

 **WARNING**

j) Do not splice the AC power cord, as this voids the three year Limited Warranty.

k) Even though the Minn Kota charger is capable of operating in a high ambient temperature environment, a minimum of six inches of unobstructed area should be allowed on all sides of the unit for proper air circulation and cooling. Proper cooling and circulation will allow the charger to operate at peak efficiency.

l) Keyhole slots are not to be used for installing the charger.

14. MOUNTING THE CHARGER - Due to the weight of the charger and the impact that boats routinely endure, take the time to securely mount the charger to prevent damage. Mounting with nuts, bolts and washers is preferable to mounting with screws.

- a) Charger was designed to be mounted in any orientation on the boat.
- b) Use the largest diameter bolts possible and use all four mounting holes.
- c) After marking the locations, set the charger aside and drill the holes.
- d) Apply a marine grade silicone sealant in each of the drilled holes to create a waterproof seal.
- e) Then secure the charger in place using the mounting hardware.

NOTICE: Your battery charger is supplied with an AC plug holder designed to hold the power cord plug when not in use. Mount the AC plug holder with four screws in a convenient dry site to prevent corrosion to the AC plug and to prevent the AC plug from making contact with the battery posts.

 **WARNING**

f) Make sure the charger is disconnected from AC power before connecting the batteries to the output cords.

 **CAUTION**

g) Before making any connections to batteries in a confined space (such as a battery compartment of a boat), open the door or hatch of the compartment and allow it to air out for 15 minutes. This allows any gases that have accumulated in the compartment to escape.



SAFETY INSTRUCTIONS

15. DC CONNECTION PRECAUTIONS

a) Connect and disconnect dc output terminals only after removing ac cord from electric outlet. Never allow output terminals to touch each other.

b) Attach output terminals to battery and chassis as indicated in 16(e), 16(f), and 17(b).

16. FOLLOW THESE STEPS WHEN BATTERY IS INSTALLED IN VEHICLE. A SPARK NEAR BATTERY MAY CAUSE BATTERY EXPLOSION. TO REDUCE RISK OF A SPARK NEAR BATTERY:

a) Position ac and dc cords to reduce risk of damage by hood, door, or moving engine part.

b) Stay clear of fan blades, belts, pulleys, and other parts that can cause injury to persons.

c) Check polarity of battery posts. POSITIVE (POS, P, +) battery post usually has a larger diameter than NEGATIVE (NEG, N, -) post.

d) Determine which post of battery is grounded (connected) to the chassis. If negative post is grounded to chassis (as in most vehicles), see (e). If positive post is grounded to the chassis, see (f).

e) For negative-grounded vehicle, connect POSITIVE (RED) output terminal from battery charger to POSITIVE (POS, P, +) ungrounded post of battery. Connect NEGATIVE (BLACK) output terminal to vehicle chassis or engine block away from battery. Do not connect output terminal to carburetor, fuel lines, or sheet-metal body parts. Connect to a heavy gage metal part of the frame or engine block. (Refer to Figure 1).

f) For positive-grounded vehicle, connect NEGATIVE (BLACK) output terminal from battery charger to NEGATIVE (NEG, N, -) ungrounded post of battery. Connect POSITIVE (RED) output terminal to vehicle chassis or engine block away from battery. Do not connect output terminal to carburetor, fuel lines, or sheet-metal body parts. Connect to a heavy gage metal part of the frame or engine block. (Refer to Figure 2).

g) When disconnecting charger, disconnect AC cord, remove output terminal from vehicle chassis, and then remove output terminal from battery terminal.

h) See operating instructions for length of charge information.

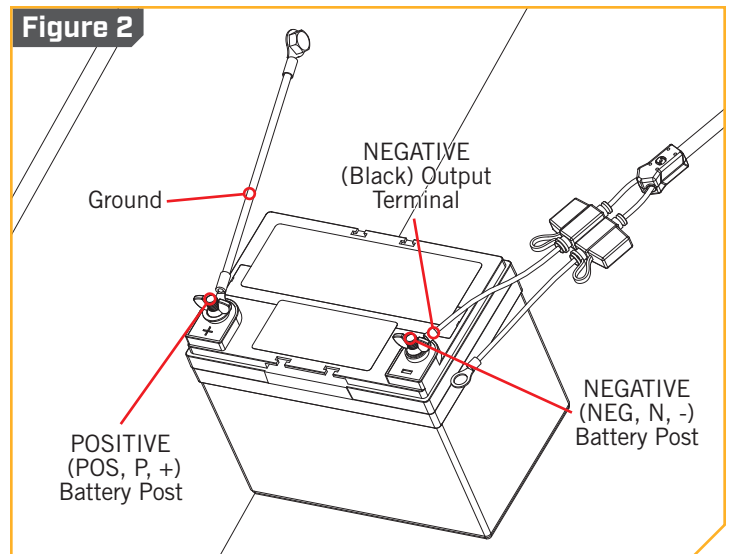
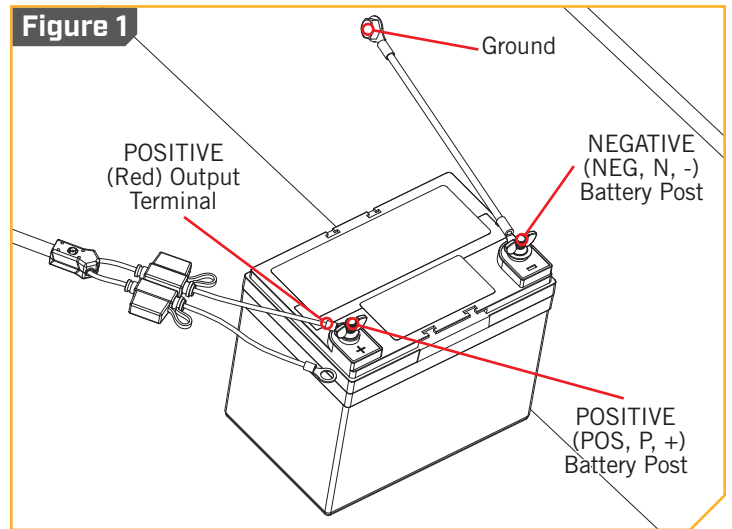

SAFETY INSTRUCTIONS



17. FOLLOW THESE STEPS WHEN BATTERY IS OUTSIDE VEHICLE. A SPARK NEAR THE BATTERY MAY CAUSE BATTERY EXPLOSION. TO REDUCE RISK OF A SPARK NEAR BATTERY:

- a) Check polarity of battery posts. POSITIVE (POS, P, +) battery post usually has a larger diameter than NEGATIVE (NEG, N, -) post.
- b) Connect POSITIVE (RED) output terminal to POSITIVE (POS, P, +) post of battery. Connect NEGATIVE (BLACK) output terminal to NEGATIVE (NEG, N, -) post of battery.
- c) Do not face battery when making final connection.
- d) When disconnecting charger, always do so in reverse sequence of connecting procedure.
- e) A marine (boat) battery does not need to be removed and charged on shore. However, instructions must be followed for location of charger when permanently mounted or used on board.

DANGER

18. DANGER - Never alter AC cord or plug provided – if it will not fit outlet, have proper outlet installed by a qualified electrician. Improper connection can result in a risk of an electric shock.

DANGER

19. DANGER - Do not attempt to repair or service the charger yourself. Opening the charger may expose you to high voltages, the risk of electric shock, and other hazards.

DANGER

20. DANGER - Do not splice the AC power cord.

CAUTION

21. CAUTION - When using an extension cord, make the AC connection to the charger outside of the battery compartment as far away as practical to reduce the risk of a spark igniting gases in the compartment.

CAUTION

22. CAUTION - Even though the Minn Kota charger is capable of operating in a high ambient temperature environment, a minimum of six inches of unobstructed area should be allowed on all sides of the unit for proper air circulation and cooling. Proper cooling and circulation will allow the charger to operate at peak efficiency.

CAUTION

23. CAUTION - Before making any connections to batteries in a confined space (such as a battery compartment of a boat), open the door or hatch of the compartment and allow it to air out for 15 minutes. This allows any gases that have accumulated in the compartment to escape.





 **CAUTION**

24. CAUTION - We recommend that you not recharge your battery, with the watercraft or motor lower unit in the water during electrical storms. Severe damage to the motor or charging system may occur if lightning strikes nearby or if storm-related high voltage conditions exist.

 **CAUTION**

25. CAUTION - If using a generator to power the charger, it must have a clean output and be safe for use on electrical equipment. Generators with a sine wave output can be used to power this charger. See the table in the Maintenance Instructions for power requirements.

 **DANGER**

26. DANGER - Damaged cords and plugs can cause electric shock or electrocution.

 **WARNING**

27. WARNING - Avoid serious injury or death from fire, explosion, or electric shock.

- This device must be connected to a Ground Fault Circuit Interrupt (GFCI) protected AC outlet
- When using an extension cord, connect the AC charger plug before connecting to the GFCI protected AC outlet
- Make connection in an open atmosphere free of explosive fumes
- Make connection in a secure manner that will avoid contact with the water



FEATURES

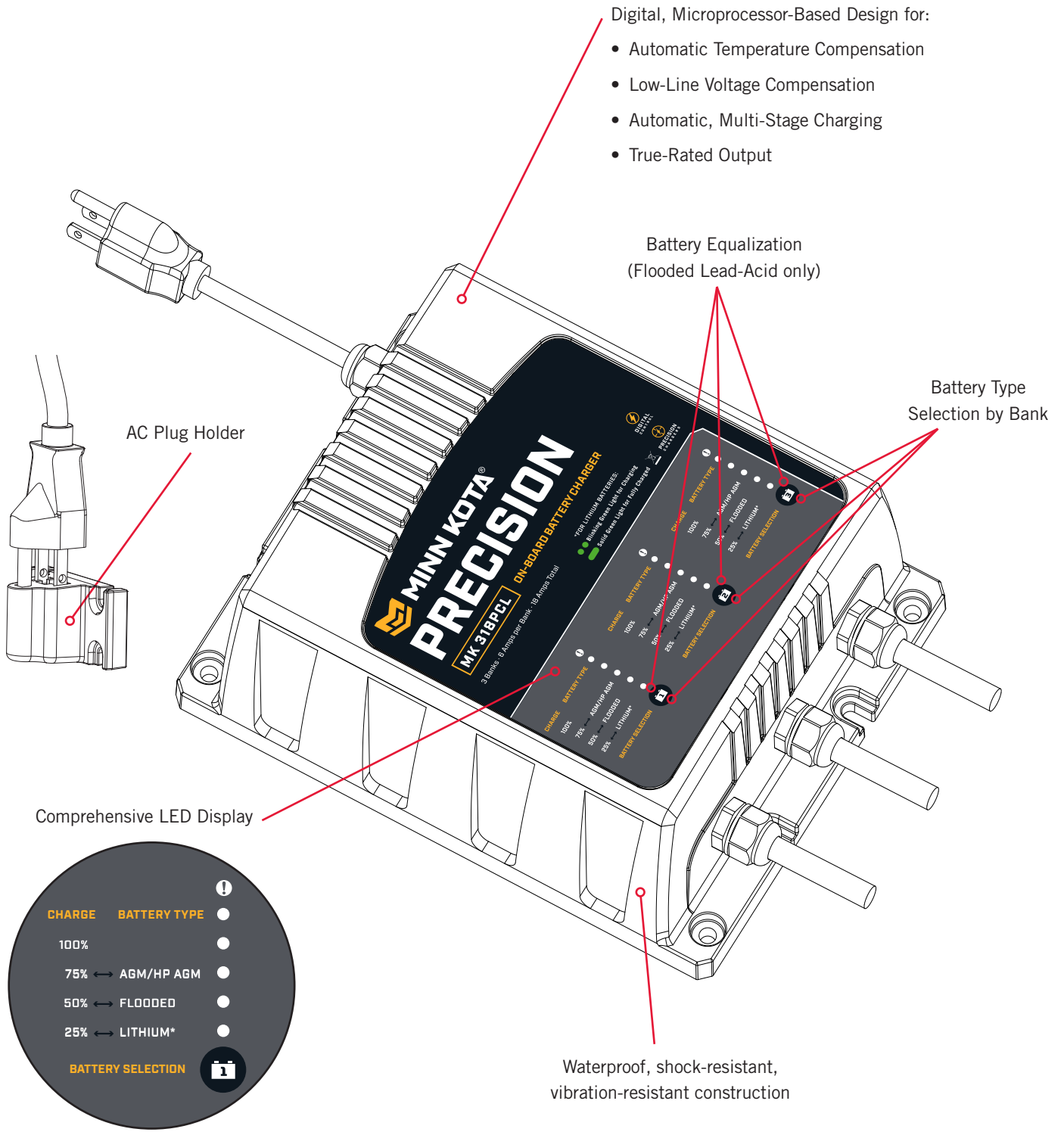

Digital, Microprocessor-Based Design for:

- Automatic Temperature Compensation
- Low-Line Voltage Compensation
- Automatic, Multi-Stage Charging
- True-Rated Output

Battery Equalization
(Flooded Lead-Acid only)

Battery Type
Selection by Bank

AC Plug Holder

Comprehensive LED Display

Waterproof, shock-resistant,
vibration-resistant construction

CHARGE **BATTERY TYPE**

100% ●

75% ↔ AGM/HP AGM ●

50% ↔ FLOODED ●

25% ↔ LITHIUM* ●

BATTERY SELECTION

NOTICE: Specifications subject to change without notice. This diagram is for reference only and may differ from your actual product.

INSTALLATION

INSTALLATION AND MOUNTING

Please take the following recommendations into consideration when locating a mounting location and installing the charger.

LOCATING A MOUNTING LOCATION FOR THE CHARGER »

1. Never place charger above battery being charged; gases from battery will corrode and damage charger.
2. Never allow battery acid to drip on charger when reading electrolyte specific gravity or filling battery.
3. Do not operate charger in a closed-in area or restrict ventilation in any way.
4. Do not set a battery on top of charger.
5. Do not mount the charger below the waterline of the boat or directly adjacent to fuel tanks.
6. Each DC output cord is six feet long. Make sure that all DC output cords can reach the batteries and that the AC power cord can reach a power source. When using an extension cord, make the AC connection to the charger outside of the battery compartment as far away as practical to reduce the risk of a spark igniting gases in the compartment.
7. Do not shorten the DC output cords, as this can affect charger output. If the DC output cords are not long enough, they may be lengthened by splicing and soldering 12 AWG (minimum) wire. Each splice should be covered with dual wall adhesive-lined heat shrink tubing to protect the joint from corroding. The splice should be made between the fork in the output cable and the fuse holder. The fuse holder should always remain within 7" of the battery terminals. The maximum extension length is 15 feet. You may contact the Minn Kota Service Department with any questions.

WARNING

Do not splice the AC power cord, as this voids the three year Limited Warranty.

8. Even though the Minn Kota charger is capable of operating in a high ambient temperature environment, a minimum of six inches of unobstructed area should be allowed on all sides of the unit for proper air circulation and cooling. Proper cooling and circulation will allow the charger to operate at peak efficiency.

MOUNTING THE CHARGER >

Due to the weight of the charger and the impact that boats routinely endure, take the time to securely mount the charger to prevent damage. Mounting with nuts, bolts and washers is preferable to mounting with screws.

1. Use the largest diameter bolts possible and use all four mounting holes.
2. After marking the locations, set the charger aside and drill the holes.
3. Apply a marine grade silicone sealant in each of the drilled holes to create a waterproof seal.
4. Then secure the charger in place using the mounting hardware.

WARNING

Make sure the charger is disconnected from AC power before connecting the batteries to the output cords.

CAUTION

Before making any connections to batteries in a confined space (such as a battery compartment of a boat), open the door or hatch of the compartment and allow it to air out for 15 minutes. This allows any gases that have accumulated in the compartment to escape.

NOTICE: Your battery charger is supplied with an AC plug holder designed to hold the power cord plug when not in use. Mount the AC plug holder with four screws in a convenient dry site to prevent corrosion to the AC plug and to prevent the AC plug from making contact with the battery posts.

INSTALLATION

INSTALLING THE MK-EC BATTERY CHARGER EXTENSION CABLE

The Minn Kota Battery Charger Extension Cables are ideal for extending charger output cables that do not reach the bow, center or transom battery compartments. Features easy installation with waterproof adhesive heat shrink for use in saltwater environments. Each conductor is fused for protection against accidental short circuits.

NOTICE: The MK-EC Battery Charger Extension Cable (#1820089) is an optional kit that is NOT included with the charger.

INSTALLATION PARTS LIST

Item / Assembly	Part #	Description	Qty.
1	✖	15FT EXTENSION CABLE	1
2	✖	WIRE SPLICE	2
3	✖	ADHESIVE HEAT SHRINK	2

✖ This part is included in an assembly and cannot be ordered individually.

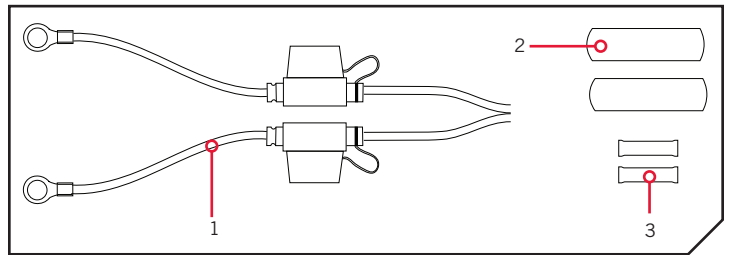

TOOLS AND RESOURCES REQUIRED

- Wire Cutters
- Wire Strippers
- Crimpers
- Heat Gun

INSTALLATION

- Remove AC power from your charger and disconnect the charger from ALL batteries.
 - Open the door or hatch of the compartment and allow it to air out for 15 minutes. This allows any gases that have accumulated in the compartment to escape.
 - Find the Charger Output Cable you would like to extend and use the wire cutters to cut the red or white (positive) and black (negative) wires before the Fuse Holders.

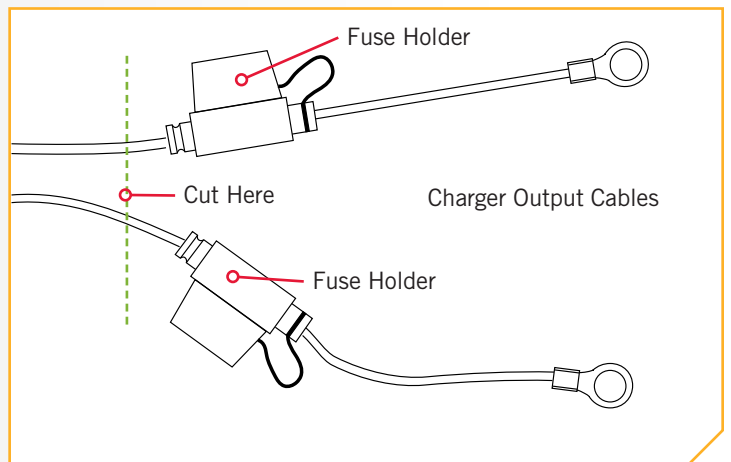

2

- d. Remove the loose pieces of insulation from the ends of the Battery Charger Extension Cable wires and crimp the Black (Negative -) Wire into the Wire Splice connector using the crimpers.
- e. Strip the Battery Charger Output Cable wires 3/8" if they are 12AWG. Strip the Battery Charger Output Cable wires 3/4" if they are 14AWG or 16AWG.
- f. Place one of the Adhesive Heat Shrinks over the Wire Splice and onto the Black (Negative -) Wire of the Battery Charger Extension Cable.
- g. For 12AWG wire, insert the Black (Negative -) Battery Charger Output Cable into the Wire Splice and crimp using the crimpers. For 14AWG or 16AWG wire, fold the stripped Black (Negative -) Battery Charger Output Cable wire in half before inserting and crimping the wire.
- h. Center the Adhesive Heat Shrink over the Wire Splice. Using the heat gun, warm the Adhesive Heat Shrink until it seals the connection.
- i. Repeat steps d through h for connecting the Red or White (Positive +) Wires to the Wire Splice.
- j. Prepare each battery in advance by cleaning off dirt, oil, battery corrosion, etc. Use a water and baking soda solution for cleaning corrosion. Wipe using a dry cloth.
- k. Route the Battery Charger Extension Cable away from sharp objects. Do not remove the Fuse Holders, since fuses are located on both the Red (Positive +) and Black (Negative -) Wires for protection in case of a short circuit.
- l. Now connect the Battery Charger Extension Cable to the battery. Be sure to connect the Black (Negative -) Ring Terminal to the Negative (-) Battery Post and connect the Red (Positive +) Ring Terminal to the Positive (+) Battery Post.

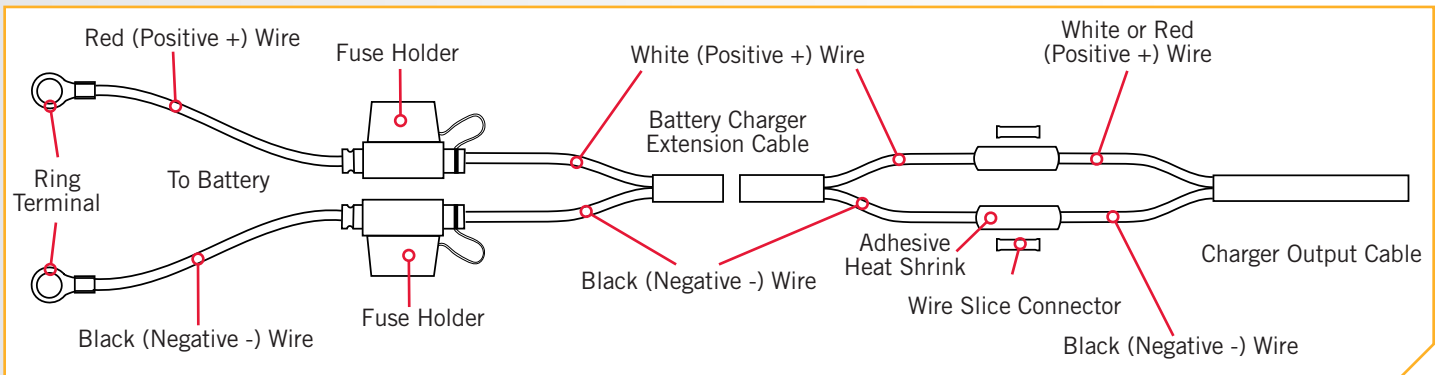

OPERATING INSTRUCTIONS

OVERVIEW

This is a high-performance battery charger that has the ability to properly and safely work with 12 Volt/6 Cell Lead-acid Batteries that are Flooded, Maintenance Free and AGM or 12V Lithium (LiFePO4) (check battery manufacturer's specifications) only. It is important to read and understand how to properly use the battery charger before charging batteries.

Each Output Bank is independent and isolated from one another and the AC Input. The Minn Kota charger can charge independent batteries or combinations of batteries hooked in series or parallel without disconnecting the batteries from any switches or Jumper Wires joining the batteries.

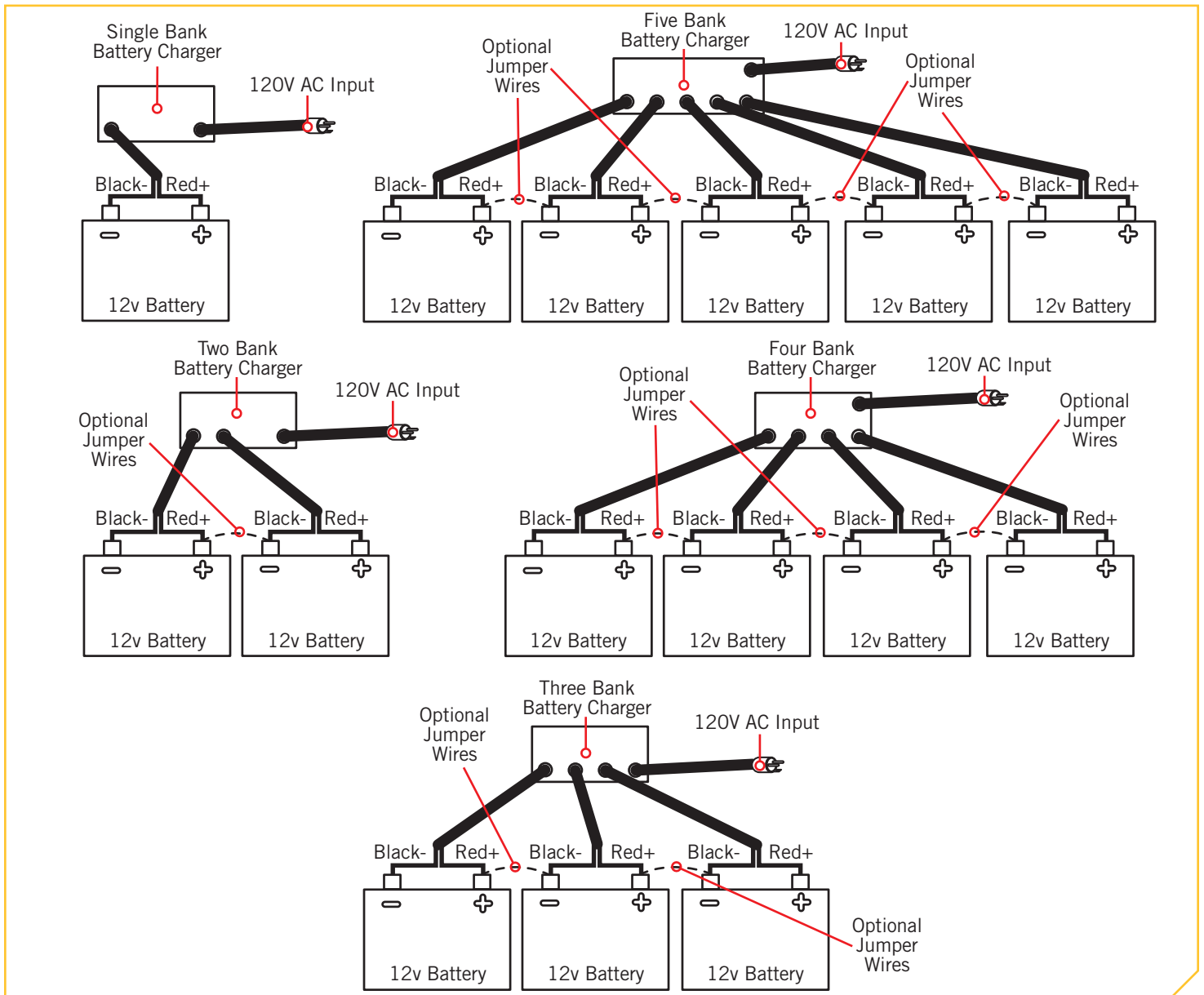

NOTICE: If batteries are connected in a series with Jumper Wires, those wires can be left in place during charging.

SELECTING THE BATTERY TYPE >

The charger can be manually switched between 4 different modes:

1. AGM/High Performance AGM
2. Flooded Lead-Acid
3. Lithium (LiFePO₄)
4. Equalize (for Flooded Lead-Acid)

In order to optimize the performance of your batteries or to prevent damage, you will need to properly set each charger bank for the correct battery type (each bank can be independently set). The factory default setting is Flooded Lead-Acid.

> Setting the Battery Type

1

- a. Plug the charger AC cord into the AC outlet.
- b. During power up all LEDs will temporarily turn on, then just 1 YELLOW LED will remain on. This YELLOW LED will indicate the current battery type selected.
- c. To change battery type, press and hold the Battery Selection  button until the YELLOW LED indicates the desired battery type, then release the button. The battery type will be saved even if the AC cord or DC output cords are disconnected.

NOTICE: The battery type will be saved even if the AC cord or DC output cords are disconnected. When the charger is powered "on", the battery type selected will be recalled from memory.

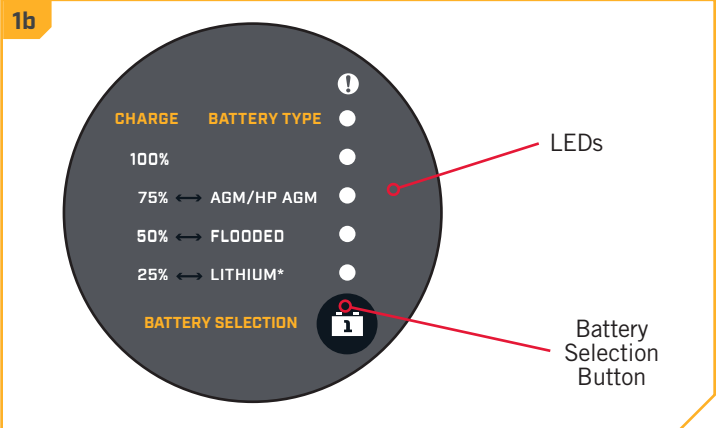
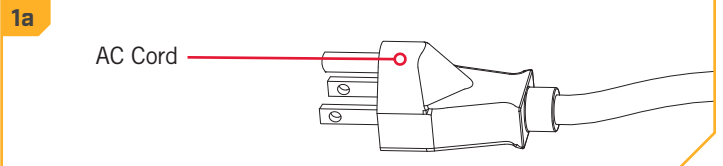

WARNING

Battery type is factory preset for Flooded Lead-Acid. If you are using alternate type batteries, select Lithium (LiFePO₄) or AGM/High Performance AGM. Failure to select the correct battery type could result in damage to your battery and/or cause acid leaks.

> Setting Equalize Mode for Flooded Lead-Acid Batteries

Flooded Lead-Acid batteries should be equalized per the battery manufacturers' recommendations. Only Flooded Lead-Acid batteries should be equalized. The charger will only allow selection of the Equalize Mode if the previous selection was Flooded Lead-Acid. To set Equalize Mode, press and hold the Battery Selection button until all 3 YELLOW LEDs are lit, then release the button. Once in Equalize Mode, the equalize process will only be performed one time. Once this cycle is completed or if the cycle is interrupted (by unplugging the AC or a DC cord), the charger will revert back to the Flooded Lead-Acid battery type.

OPERATING INSTRUCTIONS



GENERAL OPERATION >

WARNING

Make sure the charger is disconnected from AC power before connecting the batteries to the output cords.

After the AC cord on the charger is plugged in and a battery is connected to the output cable correctly, the 25% charging LED will turn on. After 2 seconds, the charger will begin charging the battery. The YELLOW LEDs will indicate how far the charger is in the charging process. Once the 100% GREEN LED is blinking, the charger is holding the float voltage. The charger will hold the batteries float voltage for 24 hours. After 24 hours, the charger output will turn off and the 100% blinking GREEN LED will switch to steady GREEN. For specifics on Lithium Batteries, please see the "LED Patterns" section of this Manual.

Lithium batteries can shut themselves off after extensive use under certain conditions. This protective condition is referred to as Standby Mode. Refer to your Lithium Battery Owner's Manual to learn more about conditions that could activate Standby Mode. Your Minn Kota charger has an Auto Start system set up to automatically restart the battery a set number of times to take the Lithium Battery out of Standby Mode so that it can be charged.

NOTICE: If a  RED LED is blinking, reference the ERROR CONDITIONS in the "Troubleshooting" section of this manual to determine the reason and take the necessary corrective action to remedy the situation. If you are unable to remedy the situation and need help, call the Minn Kota Service Department at 1.800.227.6433 and a technical support representative will be happy to assist you.

CAUTION

We recommend that you not recharge your battery, (or batteries), with the watercraft or motor lower unit in the water during electrical storms. Severe damage to the motor or charging system may occur if lightning strikes nearby or if storm- related high voltage conditions exist.

CAUTION

If using a generator to power the charger, it must have a clean output and be safe for use on electrical equipment. Generators with a sine wave output can be used to power this charger. See "Power Requirements" table for details.

WARNING

To reduce risk of electric shock, do not perform any servicing other than those contained in the operating instructions.

Power Requirements	
Model	Input Power (120VAC, 60Hz)
MK 106PCL	90W
MK 212PCL	180W
MK 318PCL	270W
MK 110PCL	150W
MK 220PCL	300W
MK 330PCL	450W
MK 440PCL	600W
MK 550PCL	750W

INLINE FUSE >

Each output cord has inline fuses on the RED and BLACK leads located near the ring terminals. These fuses serve as protection from surges and short circuits caused by a damaged charger output cable. If a fuse blows, replace it with a 30 amp ATC 32V automotive fuse. Improper battery connections will normally not cause a fuse to blow since this is handled by the internal circuitry of the charger.



OPERATING INSTRUCTIONS

MULTI-STAGE CHARGING >

Minn Kota's Multi-Stage Charging delivers a fast, precise charge profile by automatically controlling current and voltage without overcharging your batteries.

> Bulk Mode

During this stage, the charger delivers full current until the battery reaches ~75% charge. When charging Lithium batteries, the charger will stay in Bulk Mode until the process is complete.

> Absorption Mode

The charging current tapers down while the battery voltage is held constant. See the "Charging Profile" information for more details.

> Mild Equalize Mode

Mild Equalize Mode is for Flooded Lead-Acid batteries only. The voltage is automatically increased with each charging cycle for a maximum of 1.5 hours to desulfate and mix fluids in each battery.

> Equalize Mode

Equalize Mode is for Flooded Lead-Acid batteries only. The Equalize mode must be manually selected for each bank that is to be equalized. The voltage is increased for a maximum of 4 hours to desulfate and mix fluids in each battery.

> Float Mode

When the battery reaches full charge, the charger voltage is reduced. See the "Charging Profile" table in the General Operation section of this Manual for voltages. A flashing 100% GREEN LED is lit for each bank to indicate the battery is charged and in Long Term mode and ready to use. After 24 hours, the charger outputs automatically turn off and a steady 100% GREEN LED is lit for each bank to indicate the battery is ready to use. The charger will automatically resume charging when the battery voltage drops below 12.6V.

LED PATTERNS >

Each bank has the following LEDs:

Lead Batteries (Flooded / AGM HP AGM):

- 25%, 50%, 75% (YELLOW) - These LEDs indicate the progress of charging.
- 100% (GREEN): Blinking GREEN LED indicates battery is fully charged in Float Mode and ready to use. Solid GREEN LED indicates battery is fully charged in long term Float Mode and ready to use.
- ⚠️ (RED) - A solid ⚠️ RED LED indicates there is an issue with a connection. A blinking ⚠️ RED LED indicates an error. See ERROR CONDITIONS in the "Troubleshooting" section of this manual.

Lithium Batteries:

- The 100% GREEN LED will blink indicating the charging process is under way and will continue until the charging process is complete.
- When the 100% GREEN LED is solid the charging process has completed and the battery is ready to go.

CHARGE	BATTERY TYPE	LED
100%		⚠️
100%		●
75% ↔	AGM/HP AGM	●
50% ↔	FLOODED	●
25% ↔	LITHIUM*	●

OPERATING INSTRUCTIONS



Charging Profile @ 25° C

Battery Type	End of Bulk	Equalize	Float
Flooded Lead-Acid	14.4V	15.5V	13.2V
AGM/High Performance AGM (Absorbed Glass Mat)	14.4V	n/a	13.4V
Lithium (LiFePO ₄)	14.5V	n/a	n/a

FLOODED LEAD-ACID

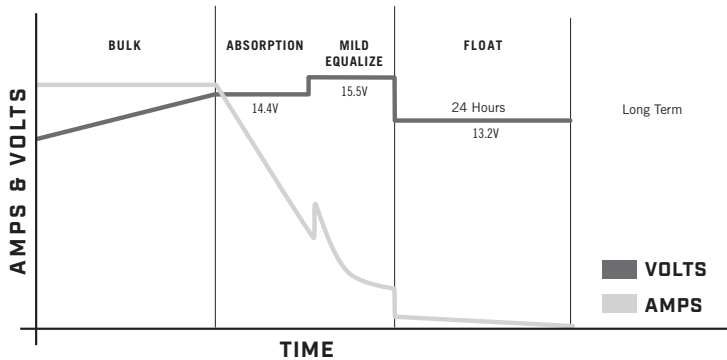

LITHIUM LiFePO₄

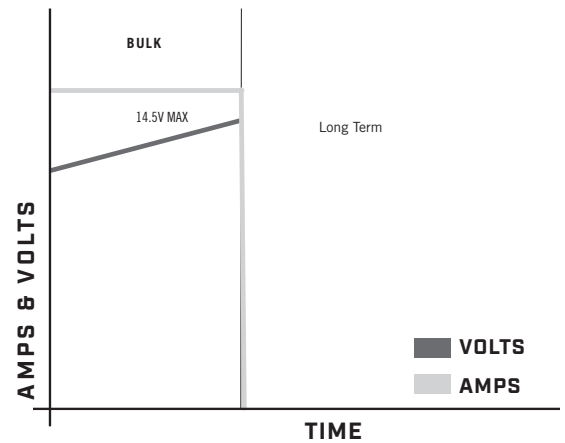

AGM / HP AGM

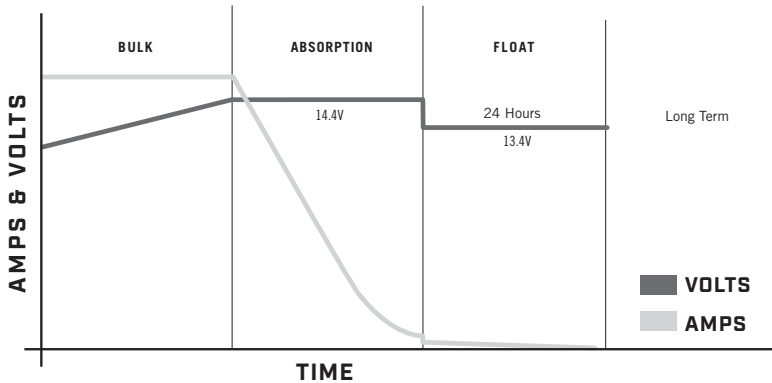

NOTICE: In long term storage, the charger will automatically resume the charging process beginning with Bulk Mode when the battery voltage drops below 12.6V.





TEMPERATURE COMPENSATION >

Temperature compensation is only applied to Lead-Acid Batteries (Flooded, AGM and HP AGM) and not required for Lithium Batteries. To optimally charge a Lead-Acid Battery, the charging voltages need to be adjusted as the temperature of the battery changes. As the temperature of the battery increases, the charging voltage should be decreased to prevent the battery from being over charged. As the temperature of the battery decreases, the charging voltage should be increased to prevent under-charging of the battery. Only the "End of Bulk" voltage is adjusted with temperature. For every degree C the temperature changes, the voltages are adjusted by 0.024 Volts.



TROUBLESHOOTING

ERROR CONDITIONS

Error	Solution
A solid  RED LED for each bank is lit	<ul style="list-style-type: none"> No battery is connected to an output cord. This may also indicate a blown fuse in the fuse holder. The battery is connected reverse polarity. A short circuit. The battery voltage is below 0.5 volts. The bank will not charge a battery in this condition. If in Lithium Mode, the charger will attempt to wake the battery from Standby Mode. The battery voltage is above 16 volts. The bank will not charge a battery in this condition.
A blinking  RED LED with solid 25% YELLOW LED	<ul style="list-style-type: none"> The battery did not rise above 10.5V within a specific time limit or the battery did not complete the Bulk Mode stage withing a specific time limit. The battery may be damaged and will not continue to be charged.
A blinking  RED LED with solid 50% YELLOW LED	<ul style="list-style-type: none"> There is a damaged temperature sensor. The bank will not operate if this occurs.
A blinking  RED LED with solid 75% YELLOW LED	<ul style="list-style-type: none"> The charger overheated. Unplug the charger and allow it to cool before resuming the charging process.
A blinking  RED LED with solid 25%, 50% and 75% YELLOW LEDs	<ul style="list-style-type: none"> The charger is set to Lithium Mode and the charger exceeded the number of attempts allowed to wake the battery from Standby Mode.
A blinking GREEN and 25% YELLOW LEDs	<ul style="list-style-type: none"> The battery is less than 10.5 volts and the charger is in low power output safety mode. Full charging will begin once the battery reaches 10.5 volts. If the battery voltage does not rise above 10.5 volts, then make sure all loads are disconnected from the battery and try again.

Specifications Input Voltage: 95-135VAC, 60Hz

Model	Part No.	System Volts	Banks	Output per Bank (amps)	Total Output (amps)	Input Cable	Output Cable	Size D x H x W (inches)	Weight (lbs)	Input Current (120VAC, 60Hz)
MK 106PCL	1831061	12	1	6	6	18AWG - 6'	16AWG - 6'	9-7/8 x 3-1/2 x 4	4	2A
MK 212PCL	1832121	12 / 24	2	6	12	18AWG - 6'	16AWG - 6'	9-7/8 x 3-1/2 x 5-7/8	6.4	4A
MK 318PCL	1833181	12 / 24 / 36	3	6	18	18AWG - 6'	16AWG - 6'	9-7/8 x 3-1/2 x 7-3/4	8.4	6A
MK 110PCL	1831101	12	1	10	10	18AWG - 6'	16AWG - 6'	9-7/8 x 3-1/2 x 4	4	2.8A
MK 220PCL	1832201	12 / 24	2	10	20	18AWG - 6'	16AWG - 6'	9-7/8 x 3-1/2 x 5-7/8	6.4	5.6A
MK 330PCL	1833301	12 / 24 / 36	3	10	30	18AWG - 6'	16AWG - 6'	9-7/8 x 3-1/2 x 7-3/4	8.4	8.4A
MK 440PCL	1834401	12 / 24 / 36 / 48	4	10	40	16AWG - 6'	16AWG - 6'	9-7/8 x 3-1/2 x 9-7/8	10.5	11.2A
MK 550PCL	1835500	12 / 24 / 36 / 48 / 60	5	10	50	16AWG - 6'	16AWG - 6'	9-7/8 x 3-1/2 x 11-3/4	12.5	13A

FREQUENTLY ASKED QUESTIONS

FREQUENTLY ASKED QUESTIONS

1. How do I determine what battery type is selected on my Minn Kota PCL Charger?
 - After AC Power is applied the yellow LED located next to the corresponding battery type is illuminated for 2 seconds. After the 2 seconds completes the LEDs will then begin to indicate the state of the charging process. The battery type can also be verified while the charger is in the process of charging. To do this you simply push and release the battery selections button. The charger will then stop the charging process, indicate the battery typing using the yellow LEDs then resume the charging process.
2. How warm do Minn Kota battery chargers get?
 - Minn Kota Chargers are designed to work within the limits defined in UL 1236 for marine battery chargers. The maximum recommended ambient temperature is 122° F. Even though the Minn Kota charger is capable of operating in a high ambient temperature environment, a minimum of six inches of unobstructed area should be allowed on all sides of the unit for proper air circulation and cooling.
3. Are the chargers serviceable?
 - There are no serviceable components inside the charger.
4. Can I hook up 2 charger outputs to one battery?
 - Yes, this will charge the battery almost twice as fast because it doubles the battery charging current. The maximum safe charging current for your battery should be verified. Always check battery manufacturer's specifications for safe charging currents. For flooded lead-acid batteries, the fluid in the battery is more likely to evaporate with higher charging currents. The fluid level should be checked frequently.
5. If batteries are connected in parallel, can I use one output from my Minn Kota Charger to charge the batteries?
 - Yes, however, it will take longer to charge multiple batteries. The battery chargers are equipped with built-in safety timers to prevent overcharging of a single battery. If the time to charge multiple batteries connected in parallel exceeds specific time limits, the charger will shut off. To fully charge multiple batteries connected in parallel, you may have to unplug and re-plug in the charger to reset the safety timers and finish the charging process. When connecting batteries in parallel, the batteries should be the same make, model, age and condition. Always check battery manufacturer's specifications.
6. Will I damage my batteries if I leave the charger plugged in over long periods of time when it is not in use?
 - No. Minn Kota's On-board chargers operate in Float Mode where they maintain the battery voltage for 24 hours and then transition to Long Term Storage Mode. During this time the Charger no longer outputs power to the battery and only monitors the voltage. It will automatically resume charging when the battery voltage drops.



SERVICE & MAINTENANCE



GENERAL MAINTENANCE

- Check battery charger for dirt, oil, battery corrosion, etc. Use a water and baking soda solution for cleaning corrosion. Wipe clean using a dry cloth.
- Check ring terminals for dirt, oil, and battery corrosion; then disconnect from battery posts and clean as necessary with water and baking soda solution and dry with a clean cloth.
- When the charger is not in use, coil the power cord to prevent damage.
- When storing the battery charger, store in a clean dry area.
- If power cord or plug becomes damaged, you may contact the Minn Kota Service Repair Department for service repair information. Otherwise, dispose of the battery charger in compliance with local law. Damaged cords and plugs can cause electric shock or electrocution.



COMPLIANCE STATEMENTS

ENVIRONMENTAL COMPLIANCE STATEMENT

It is the intention of JOME to be a responsible corporate citizen, operating in compliance with known and applicable environmental regulations, and a good neighbor in the communities where we make or sell our products.

WEEE DIRECTIVE

EU Directive 2002/96/EC “Waste of Electrical and Electronic Equipment Directive (WEEE)” impacts most distributors, sellers, and manufacturers of consumer electronics in the European Union. The WEEE Directive requires the producer of consumer electronics to take responsibility for the management of waste from their products to achieve environmentally responsible disposal during the product life cycle.

WEEE compliance may not be required in your location for electrical & electronic equipment (EEE), nor may it be required for EEE designed and intended as fixed or temporary installation in transportation vehicles such as automobiles, aircraft, and boats. In some European Union member states, these vehicles are considered outside of the scope of the Directive, and EEE for those applications can be considered excluded from the WEEE Directive requirement.

This symbol (WEEE wheelie bin) on product indicates the product must not be disposed of with other household refuse. It must be disposed of and collected for recycling and recovery of waste EEE. Johnson Outdoors Inc. will mark all EEE products in accordance with the WEEE Directive. It is our goal to comply in the collection, treatment, recovery, and environmentally sound disposal of those products; however, these requirements do vary within European Union member states. For more information about where you should dispose of your waste equipment for recycling and recovery and/or your European Union member state requirements, please contact your dealer or distributor from which your product was purchased.

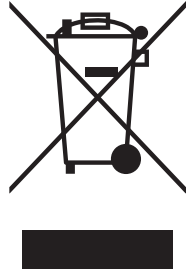

DISPOSAL

Minn Kota chargers are not subject to the disposal regulations EAG-VO (electric devices directive) that implements the WEEE directive. Nevertheless, never dispose of your Minn Kota charger in a garbage bin but at the proper place of collection of your local town council.

Never dispose of battery in a garbage bin. Comply with the disposal directions of the manufacturer or his representative and dispose of them at the proper place of collection of your local town council.

COMPLIANCE STATEMENTS



FCC COMPLIANCE

This device complies with Part 15 of the FCC rules. **Operation is subject to the following two conditions:**

1. This device may not cause harmful interference.
2. This device must accept any interference that may be received, including interference that may cause undesired operation.

Changes or modifications not expressly approved by Johnson Outdoors Marine Electronics, Inc. could void the user's authority to operate this equipment.

NOTICE: This equipment has been tested and found to comply with the limits for a Class A digital device, pursuant to part 15 of the FCC Rules. These limits are designed to provide reasonable protection against harmful interference in a residential installation. This equipment generates, uses and can radiate radio frequency energy and, if not installed and used in accordance with the instructions, may cause harmful interference to radio communications. However, there is no guarantee that interference will not occur in a particular installation. **If this equipment does cause harmful interference to radio or television reception, which can be determined by turning the equipment off and on, the user is encouraged to try to correct the interference by one or more of the following measures:**

- Reorient or relocate the receiving antenna.
- Increase the separation between the equipment and receiver.
- Connect the equipment into an outlet on a circuit different from that to which the receiver is connected.
- Consult the dealer or an experienced radio/TV technician for help.

INDUSTRY CANADA COMPLIANCE

This product meets the applicable Industry Canada technical specifications. Operation is subject to the following two conditions: (1) this device may not cause interference, and (2) this device must accept any interference, including interference that may cause undesired operation of the device.

Changes or modifications not expressly approved by Johnson Outdoors Marine Electronics, Inc. could void the user's authority to operate this equipment.

ENVIRONMENTAL RATINGS

- Ambient operating temperature range: -10C to 50C
- Ambient operating humidity range: 5% to 95%
- Maximum operating altitude: 10,000 feet



PARTS DIAGRAM & PARTS LIST

MK 106PC / MK 212PCL / MK 318PCL / MK 110PCL / MK 220PCL / MK 330PCL / MK 440PCL / MK 550PCL

The parts diagram and parts list provide Minn Kota WEEE compliance disassembly instructions. For more information about where you should dispose of your waste equipment for recycling and recovery and/or your European Union member state requirements, please contact your dealer or distributor from which your product was purchased. Tools required, but not limited to: wire cutters.

MK 106PC / MK 212PCL / MK 318PCL >

> MK 106PC / MK 212PCL / MK 318PCL Charger Parts Diagram

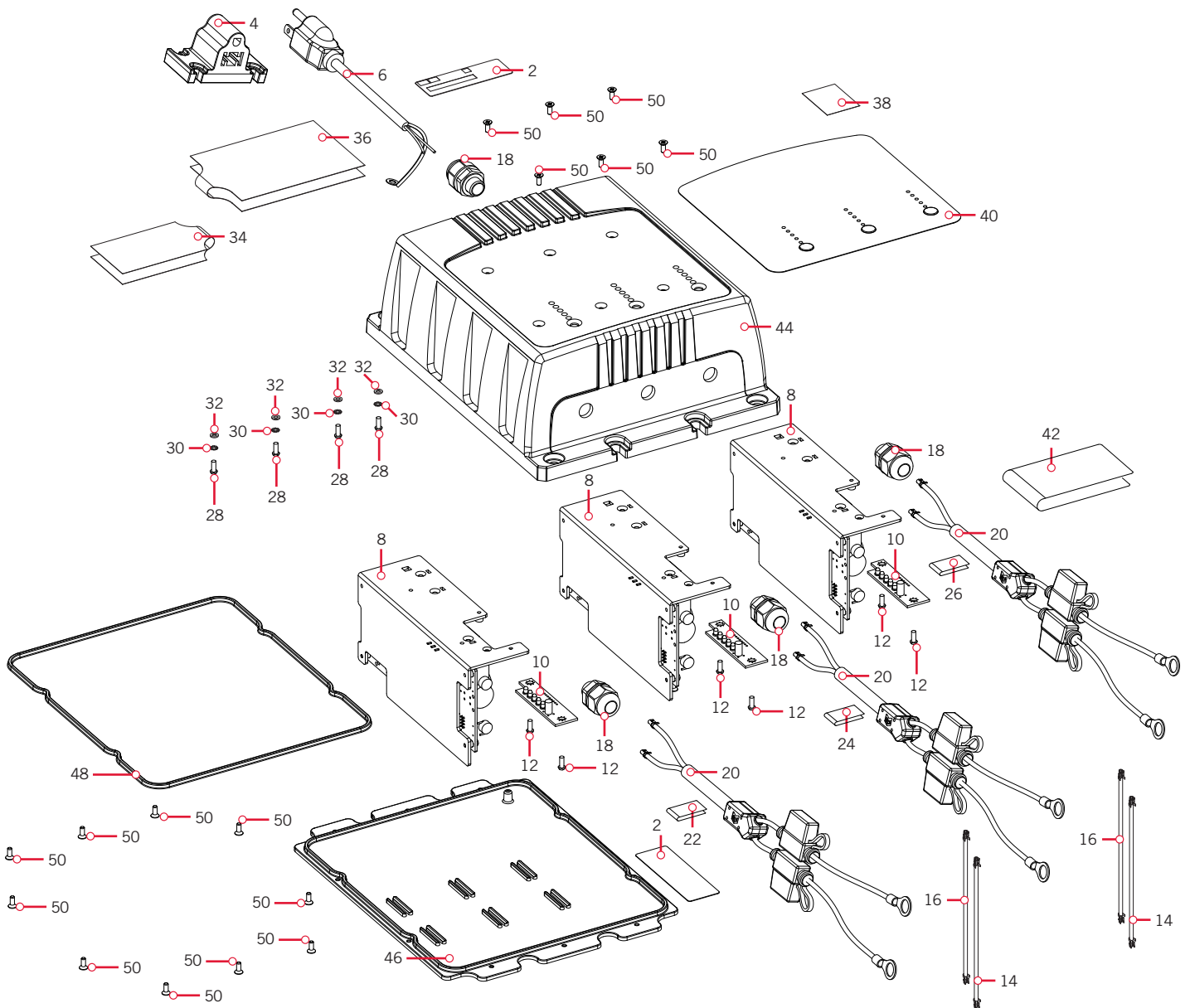

PARTS DIAGRAM & PARTS LIST

› MK 106PC / MK 212PCL / MK 318PCL Charger Parts List

Item	Part #	Description	Notes	Quantity
2	✖	DECAL-SERIAL NUMBER 3" NYLON		2
4	✖	PLUG HOLDER, AC		1
▲	✖	MANUAL, 6/10A PCL CHARGER		1
6	✖	INPUT CORD, 18AWG		1
8	✖	PCB ASM, 6A PCL CHARGER		1/2/3
▲	✖	PCB, 6A PCL CHRGR		1/2/3
▲	✖	TRANSFORMER, 6A PCL CHRGR		1/2/3
▲	✖	HEAT SINK, 6/10A PCL CHRGR		1/2/3
▲	✖	INSULATOR-LG, 6/10A PCL		1/2/3
▲	✖	INSULATOR-SM, 6/10A PCL		1/2/3
10	✖	BOARD, LED, 6/10A PCL		1/2/3
12	✖	SCREW, M3, 8MM		2/4/6
▲	✖	LOCKWASHER-STAR, M4		2/4/6
▲	✖	WASHER-3MM, ZINC PLATED STEEL		2/4/6
14	✖	AC BRD CONNECT,16 AWG,WHT	*MK-212PCL* *MK-318PCL*	1/2
16	✖	AC BRD CONNECT,16 AWG,BLK	*MK-212PCL* *MK-318PCL*	1/2
18	✖	STRAIN RELIEF, METAL PCL		2/3/4
20	✖	OUTPUT CORD,2 CONDUCTOR, 16AWG		1/2/3
22	✖	DECAL-BANK 1, WRAP AROUND	*MK-212PCL* *MK-318PCL*	1
24	✖	DECAL-BANK 2, WRAP AROUND	*MK-212PCL* *MK-318PCL*	1
26	✖	DECAL, BANK 3 WRAP AROUND	*MK-318PCL*	1
28	✖	SCREW-M4, 8MM, PCL CHRGR		2/3/4
30	✖	WASHER-4MM, SPLIT LOCK		2/3/4
32	✖	WASHER-4MM, ZP STEEL		2/3/4
34	✖	LABEL-WARNING, INPUT CORD		1
36	✖	LABEL-WARNING MK-106PCL	*MK-106PCL*	1
	✖	LABEL-WARNING MK-212PCL	*MK-212PCL*	1
	✖	LABEL-WARNING MK-318PCL	*MK-318PCL*	1
38	✖	DECAL-OVERLAY,BAT.SELECT		1
40	✖	DECAL-TOP, MK-106PCL CHRGR	*MK-106PCL*	1
	✖	DECAL-TOP, MK-212PCL CHRGR	*MK-212PCL*	1
	✖	DECAL-TOP, MK-318PCL CHRGR	*MK-318PCL*	1
42	✖	DECAL-ERROR CODE 6/10A PCL		1
44	✖	COVER-DIECAST, 1 BNK PCL	*MK-106PCL*	1
	✖	COVER-DIECAST, 2 BNK PCL	*MK-212PCL*	1
	✖	COVER-DIECAST, 3 BNK PCL	*MK-318PCL*	1

✖ This part is included in an assembly and cannot be ordered individually.

▲ Not shown on Parts Diagram.

PARTS DIAGRAM & PARTS LIST



Item	Part #	Description	Notes	Quantity
46	✘	BASE-DIECAST, 1 BNK PCL	*MK-106PCL*	1
	✘	BASE-DIECAST, 2 BNK PCL	*MK-212PCL*	1
	✘	BASE-DIECAST, 3 BNK PCL	*MK-318PCL*	1
48	✘	GASKET, 1 BNK 6/10A PCL	*MK-106PCL*	1
	✘	GASKET, 2 BNK 6/10A PCL	*MK-212PCL*	1
	✘	GASKET, 3 BNK 6/10A PCL	*MK-318PCL*	1
50	✘	SCREW-M3 FLAT,8MM 6/10 PCL		10/14/18

✘ This part is included in an assembly and cannot be ordered individually.

▲ Not shown on Parts Diagram.



PARTS DIAGRAM & PARTS LIST

MK 110PCL / MK 220PCL / MK 330PCL / MK 440PCL / MK 550PCL

MK 110PCL / MK 220PCL / MK 330PCL / MK 440PCL / MK 550PCL Charger Parts Diagram

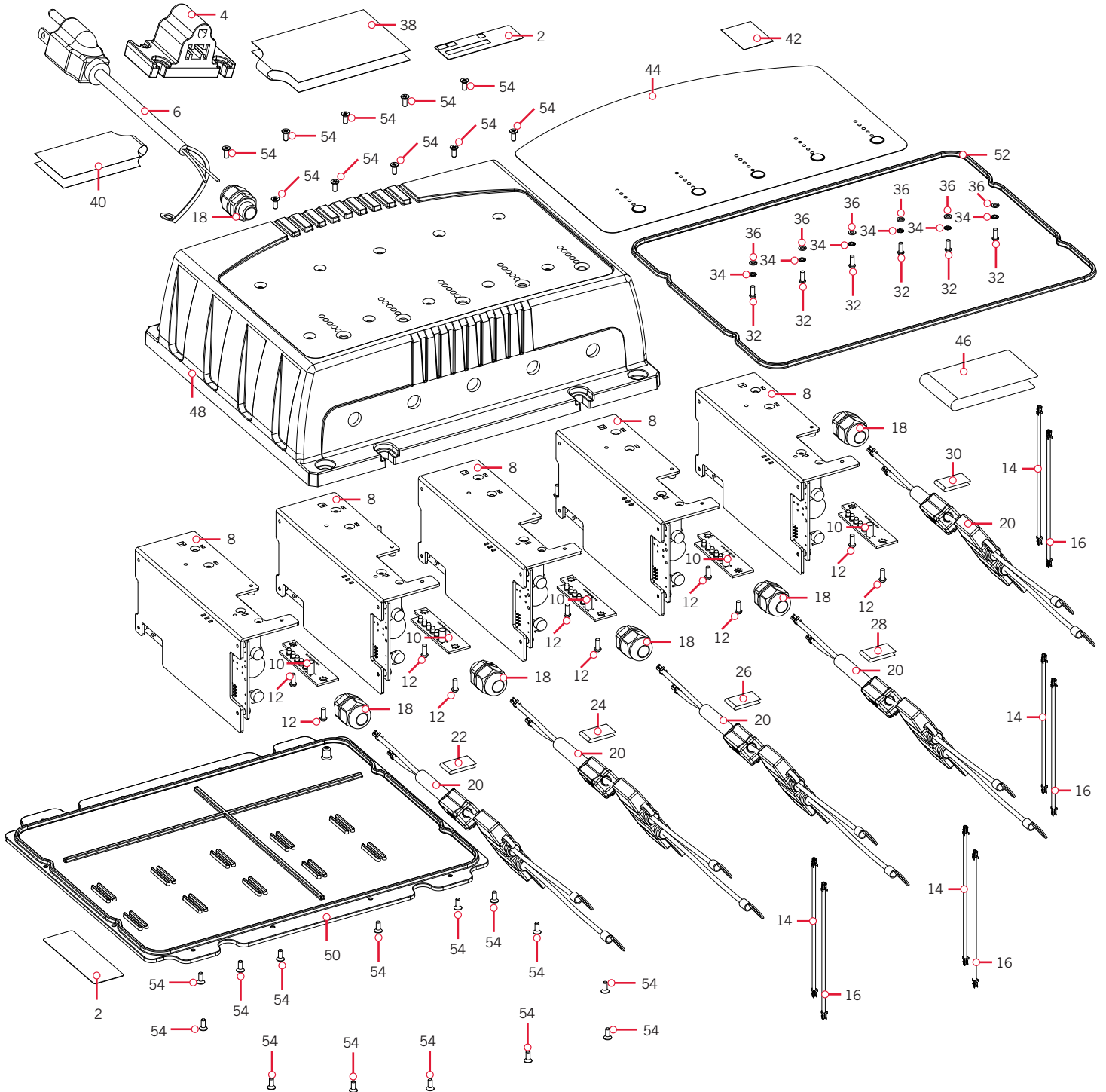

PARTS DIAGRAM & PARTS LIST

➤ MK 110PCL / MK 220PCL / MK 330PCL / MK 440PCL / MK 550PCL Charger Parts List

Item	Part #	Description	Notes	Quantity
2	✖	DECAL-SERIAL NUMBER 3" NYLON		2
4	✖	PLUG HOLDER, AC		1
▲	✖	MANUAL, 6/10A PCL CHARGER		1
6	✖	INPUT CORD, 18AWG		1
8	✖	PCB ASM, 10A PCL CHARGER		1/2/3/4/5
▲	✖	PCB, 10A PCL CHRGR		1/2/3/4/5
▲	✖	TRANSFORMER, 10A PCL CHRGR		1/2/3/4/5
▲	✖	HEAT SINK, 6/10A PCL CHRGR		1/2/3/4/5
▲	✖	INSULATOR-LG, 6/10A PCL		1/2/3/4/5
▲	✖	INSULATOR-SM, 6/10A PCL		1/2/3/4/5
10	✖	BOARD, LED, 6/10A PCL		1/2/3/4/5
12	✖	SCREW, M3, 8MM		2/3/4/5/6
▲	✖	LOCKWASHER-STAR, M4		2/3/4/5/6
▲	✖	WASHER-3MM, ZINC PLATED STEEL		2/3/4/5/6
14	✖	AC BRD CONNECT,16 AWG,WHT	*MK-220PCL* *MK-330PCL* *MK-440PCL*	1/2/3/4
16	✖	AC BRD CONNECT,16 AWG,BLK	*MK-220PCL* *MK-330PCL* *MK-440PCL*	1/2/3/4
18	✖	STRAIN RELIEF, METAL PCL		2/3/4/5/6
20	✖	OUTPUT CORD,2 CONDUCTOR, 16AWG		1/2/3/4/5
22	✖	DECAL-BANK 1, WRAP AROUND	*MK-220PCL* *MK-330PCL* *MK-440PCL* *MK-550PCL*	1
24	✖	DECAL-BANK 2, WRAP AROUND	*MK-220PCL* *MK-330PCL* *MK-440PCL* *MK-550PCL*	1
26	✖	DECAL, BANK 3 WRAP AROUND	*MK-330PCL* *MK-440PCL* *MK-550PCL*	1
28	✖	DECAL, BANK 4 WRAP AROUND	*MK-440PCL* *MK-550PCL*	1
30	✖	DECAL BANK 5 WRAP AROUND	*MK-550PCL*	1
32	✖	SCREW-M4, 8MM, PCL CHRGR		2/3/4/5/6
34	✖	WASHER-4MM, SPLIT LOCK		2/3/4/5/6
36	✖	WASHER-4MM, ZP STEEL		2/3/4/5/6
38	✖	LABEL-WARNING MK-110PCL	*MK-110PCL*	1
	✖	LABEL-WARNING MK-220PCL	*MK-220PCL*	1
	✖	LABEL-WARNING MK-330PCL	*MK-330PCL*	1
	✖	LABEL-WARNING MK-440PCL	*MK-440PCL*	1
	✖	LABEL-WARNING MK-550PCL	*MK-550PCL*	1
40	✖	LABEL-WARNING, INPUT CORD		1
42	✖	DECAL-OVERLAY,BAT.SELECT		1

✖ This part is included in an assembly and cannot be ordered individually.

▲ Not shown on Parts Diagram.

PARTS DIAGRAM & PARTS LIST



Item	Part #	Description	Notes	Quantity
44	✘	DECAL-TOP, MK-110PCL CHRGR	*MK-110PCL*	1
	✘	DECAL-TOP, MK-220PCL CHRGR	*MK-220PCL*	1
	✘	DECAL-TOP, MK-330PCL CHRGR	*MK-330PCL*	1
	✘	DECAL-TOP, MK-440PCL CHRGR	*MK-440PCL*	1
	✘	DECAL-TOP, MK-550PCL CHRGR	*MK-550PCL*	1
46	✘	DECAL-ERROR CODE 6/10A PCL		1
48	✘	COVER-DIECAST, 1 BNK PCL	*MK-110PCL*	1
	✘	COVER-DIECAST, 2 BNK PCL	*MK-220PCL*	1
	✘	COVER-DIECAST, 3 BNK PCL	*MK-330PCL*	1
	✘	COVER-DIECAST, 4 BNK PCL	*MK-440PCL*	1
	✘	COVER-DIECAST, 5 BNK PCL	*MK-550PCL*	1
50	✘	BASE-DIECAST, 1 BNK PCL	*MK-110PCL*	1
	✘	BASE-DIECAST, 2 BNK PCL	*MK-220PCL*	1
	✘	BASE-DIECAST, 3 BNK PCL	*MK-330PCL*	1
	✘	BASE-DIECAST, 4 BNK PCL	*MK-440PCL*	1
	✘	BASE-DIECAST, 5 BNK PCL	*MK-550PCL*	1
52	✘	GASKET, 1 BNK 6/10A PCL	*MK-110PCL*	1
	✘	GASKET, 2 BNK 6/10A PCL	*MK-220PCL*	1
	✘	GASKET, 3 BNK 6/10A PCL	*MK-330PCL*	1
	✘	GASKET, 4 BNK 6/10A PCL.	*MK-440PCL*	1
	✘	GASKET, 5 BNK 6/10A PCL	*MK-550PCL*	1
54	✘	SCREW-M3 FLAT,8MM 6/10 PCL		10/14/18/22/24

✘ This part is included in an assembly and cannot be ordered individually.

▲ Not shown on Parts Diagram.



RECOMMENDED ACCESSORIES

› CHARGER OUTPUT EXTENSION CABLES

Extension cables are ideal when standard charger cables will not reach bow, center or transom battery compartments. Features WAGO® Wall-Nut™ quick connectors (UL Listed). Fused (30 amp) positive and negative leads. Available in 15' length.



› AC POWER PORT (Freshwater & Saltwater)

Our convenient adapter allows quick thru-hull connection to an AC extension cord using the male AC plug from any of our chargers. No cutting or splicing required. The watertight cover and gasket prevent corrosion on the AC plug when it isn't in use.



› TALON SHALLOW WATER ANCHOR

Introducing the all-new, sleek redesigned Talon. Talon is the only shallow water anchor with up to 15' of anchoring depth, multiple anchoring modes, and control from the bow, transom, console, remote or mobile device.



BUILT-IN WORK LIGHT

Lets you tie lines and work from the transom any time of day — or night. Includes both white and blue LED lights with three brightness settings.



UP TO 15' DEEP

Control more water and catch more fish with the first 15' shallow water anchor.



BLUETOOTH® CONNECTIVITY

Lets you control Talon from your mobile device and easily update it. Also opens up communication to other control options.



MORE CONTROL OPTIONS

- Control Panel
- Wireless Remote
- Mobile App
- Wireless Foot Switch
- Humminbird® Connectivity
- i-Pilot® & i-Pilot Link™ Remote



› MINN KOTA ACCESSORIES

We offer a wide variety of trolling motor accessories, including:

- 60-Amp Circuit Breaker
- Mounting Brackets
- Stabilizer Kits
- Extension Handles
- Battery Connectors
- Battery Boxes
- Quick Connect Plugs

