

# CORDED FOOT PEDAL

FOR POWERDRIVE™ & RIPTIDE® POWERDRIVE™

COMPATIBLE WITH POWERDRIVE, POWERDRIVE V2, RIPTIDE POWERDRIVE, AND RIPTIDE SP  
MOTORS MANUFACTURED IN 2007 OR LATER

# SAFETY CONSIDERATIONS

## WARNING

You are responsible for the safe and prudent operation of your vessel. We have designed your Foot Pedal to be an accurate and reliable tool that will enhance boat operation and improve your ability to catch fish. This product does not relieve you from the responsibility for safe operation of your boat. You must avoid hazards to navigation and always maintain a permanent watch so you can respond to situations as they develop. You must always be prepared to regain manual control of your boat. Learn to operate your Foot Pedal in an area free from hazards and obstacles.

## CAUTION

For safety reasons, disconnect the motor from the battery/batteries when the motor is not in use or while the battery/batteries are being charged. If the motor control is left on, and the Foot Pedal is accidentally engaged, and the propeller rotation is blocked, severe motor damage can result.

## WARNING

Practice proper ergonomics when operating the foot pedal to prevent injury.

## COMPATIBILITY

### Compatible with PowerDrive, PowerDrive V2, Riptide PowerDrive, and Riptide SP motors manufactured in 2007 or later

Check that your motor has a round, gray foot pedal plug (not rectangular) to ensure compatibility.

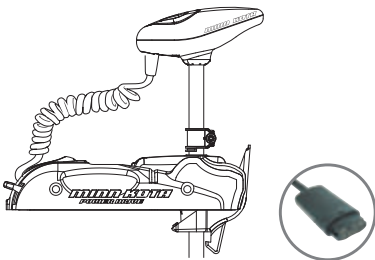

 **Legacy PowerDrive**  
that have black,  
rectangular plug

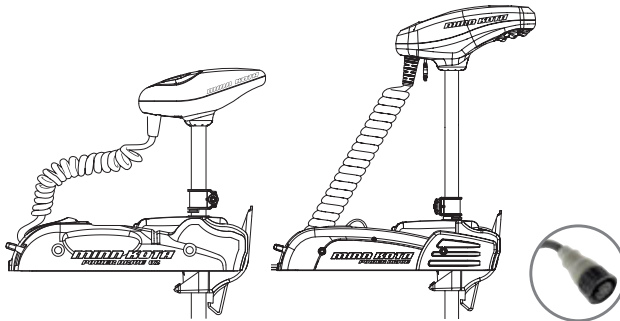

 **PowerDrive V2 or PowerDrive**  
**mfg. 2007 or after**  
that have round, gray foot pedal plug

# INSTALLATION

## INSTALLING THE POWERDRIVE & RIPTIDE POWERDRIVE FOOT PEDAL

Your new PowerDrive Foot Pedal accessory comes with everything you'll need to directly install it on your trolling motor. These instructions are intended to show how to install your new PowerDrive Foot Pedal on a PowerDrive trolling motor. Please review the parts list and mounting considerations for installation prior to getting started.

### INSTALLATION PARTS LIST

Item / Assembly	Part #	Description	Qty.
A	2994859	BAG ASY-TERROVA/V2,RUB.BUMPERS	1
B	2994727	FOOT PEDAL ASSEMBLY, PD	1
1	2377167 ▲	MANUAL-FT PEDAL, POWERDRIVE V3	1
2	2325110	PAD, FOOT PEDAL PD	5

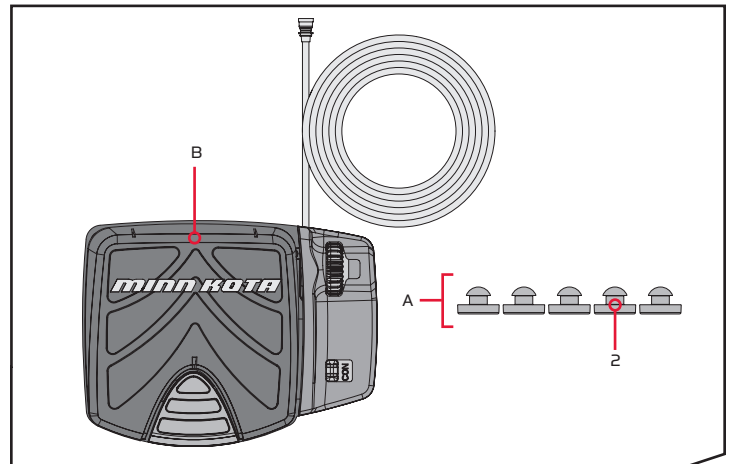

▲ Not shown on Parts Diagram.

### MOUNTING CONSIDERATIONS

Before installing your PowerDrive Foot Pedal, make sure that it is compatible with your motor. To review compatibility, please refer to the "Compatibility" section of this manual. When placing the PowerDrive Foot Pedal on your boat, select a location that will not obstruct boat operation and that is appropriate for trolling motor operation. Place the PowerDrive Foot Pedal in a foot pedal well on your boat if it has one, or any location where it will be free from water and debris.

### INSTALLATION

## Installing the PowerDrive & Riptide PowerDrive Foot Pedal

1

#### ITEM(S) NEEDED

#2 x 5

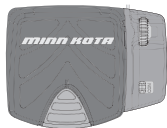

#B x 1

- Take the Foot Pedal (Item #B) and turn it over. Put a Foot Pedal Pad (Item #2) in each of the pad locations.

**NOTE:** Adding the Foot Pedal pads is optional. The pads are recommended when using the Foot Pedal on non-carpeted surfaces.

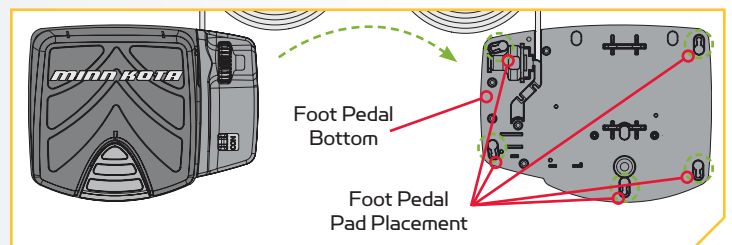

## INSTALLATION

2

- b. Locate the Foot Pedal Cord that exits the mount of the PowerDrive, next to the Power Cord.
- c. Unscrew the cap at the end of the Foot Pedal Cord that exits the motor and the cord on the Foot Pedal.
- d. Plug the cords together and make sure the connection is secure. Be sure to tighten the connector retaining nut.

**NOTE:** The connectors are keyed to prevent reversed installation.

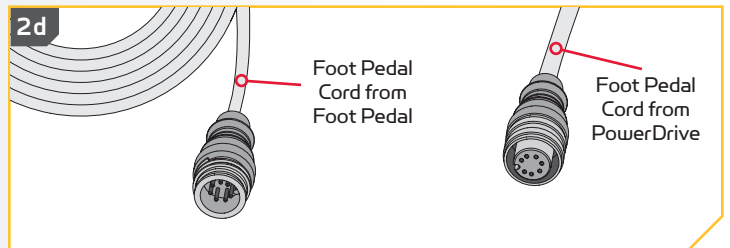
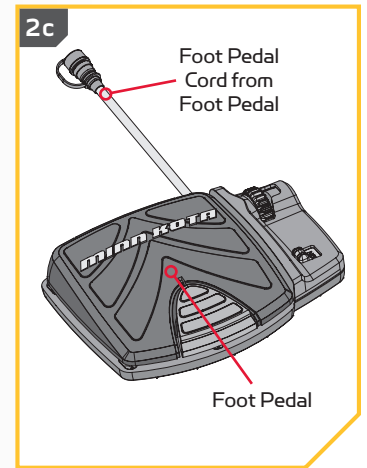
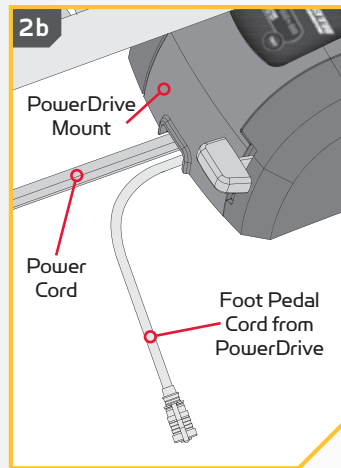

# USING THE FOOT PEDAL

## CONTROLLING SPEED & STEERING WITH THE FOOT PEDAL

The foot pedal is used to operate the motor, and controls on the foot pedal are easy to operate by either foot or hand. The motor can also be controlled by an i-Pilot remote, or a compatible Minn Kota remote if equipped with an appropriate i-Pilot or CoPilot receiver. Please refer to the i-Pilot or compatible remote manual on how the remote controls the motor.

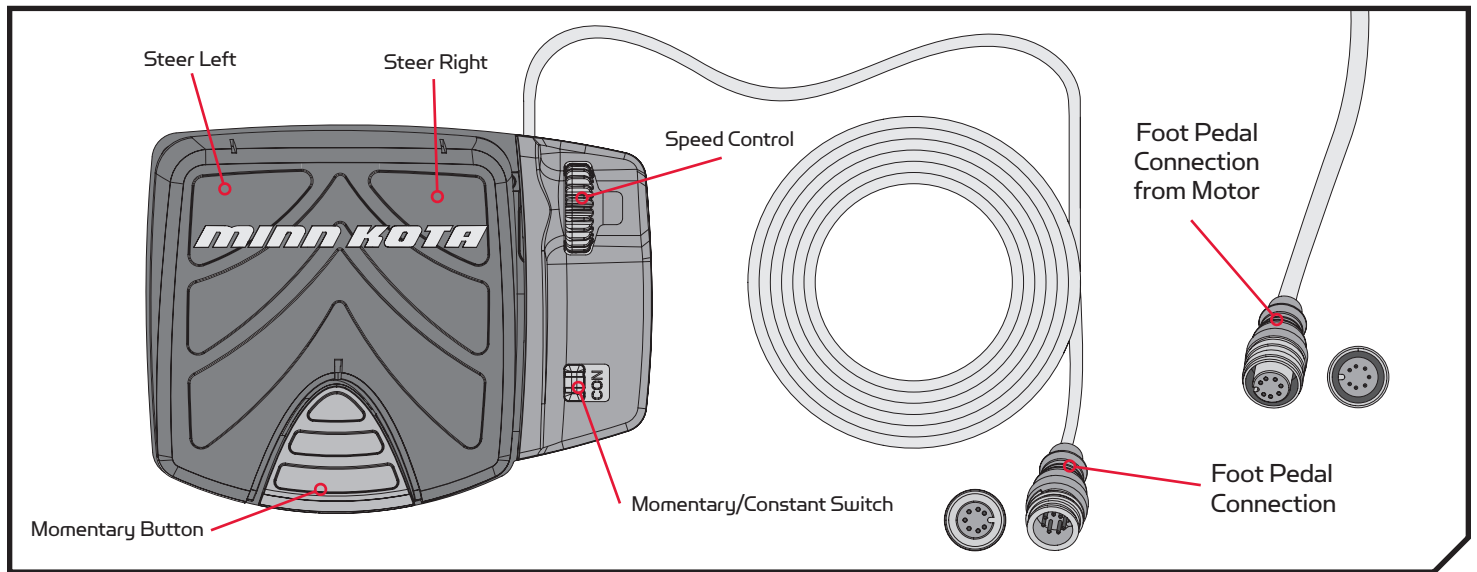

### Momentary Button

The Momentary Button is located at the heel end of the foot pedal and is used to turn the propeller on.

### Momentary/Constant Switch

The Momentary/Constant Switch is used to toggle between Momentary and Constant Mode. During Momentary Mode (MOM), the propeller only turns while pressure is applied to the Momentary Button. While in Constant Mode (CON), the propeller will run continuously regardless of pressure being applied to the Momentary Button.

If a propeller encounters an obstruction while either in Momentary or Constant Mode, while the propeller is running, the increased electrical current being generated by the obstruction will signal the motor to decrease the power to the propeller to prevent damage. If the current overload is detected for more than 20 seconds, the prop will be disabled to prevent damage to the motor. In this event, the operator can turn the prop back on after being sure that the obstruction has been cleared.

### Speed Control

The Speed Control dial is on the upper right side of the toe end of the Foot Pedal. Turn the Speed Knob forward to increase speed and backward to decrease speed. Speed can also be adjusted using the remote, if applicable.

### Steer Right and Steering Left

The main button on the foot pedal is to control steering. Steer Right by applying pressure to the right side of the button and Steer Left by applying pressure to the left side of the button. The position and direction of the Steering Head directly corresponds to the position of the motor. You must use your foot on the pedal to control the steering direction during manual operation. The direction of the motor can also be controlled with the remote, if the motor is properly equipped with the appropriate receiver.



## CAUTION

The steering system is designed to turn your motor 360°. Be careful to avoid over-wrapping the coil cord around the composite shaft. Damage to the coil cord can occur when it is over-wrapped, which will prevent the motor from operating correctly.

## USING THE FOOT PEDAL

---

### Steering in Reverse

The propeller always turns in the forward direction. You can reverse the direction of thrust by turning the motor 180°.

**NOTE:** The motor will not auto correct to drive straight.

### **WARNING**

You are responsible for the safe and prudent operation of your vessel. We have designed PowerDrive to be an accurate and reliable tool that will enhance boat operation and improve your ability to catch fish. This product does not relieve you from the responsibility for safe operation of your boat. You must avoid hazards to navigation and always maintain a permanent watch so you can respond to situations as they develop. You must always be prepared to regain manual control of your boat. Learn to operate your PowerDrive in an area free from hazards and obstacles.

### **CAUTION**

For safety reasons, disconnect the motor from the battery/batteries when the motor is not in use or while the battery/batteries are being charged. If the motor control is left on and the propeller rotation is blocked, severe motor damage can result.

### **WARNING**

Practice proper ergonomics when operating the foot pedal to prevent injury.



# COMPLIANCE STATEMENTS

## ENVIRONMENTAL COMPLIANCE STATEMENT

It is the intention of JOME to be a responsible corporate citizen, operating in compliance with known and applicable environmental regulations, and a good neighbor in the communities where we make or sell our products.

## WEEE DIRECTIVE

EU Directive 2002/96/EC “Waste of Electrical and Electronic Equipment Directive (WEEE)” impacts most distributors, sellers, and manufacturers of consumer electronics in the European Union. The WEEE Directive requires the producer of consumer electronics to take responsibility for the management of waste from their products to achieve environmentally responsible disposal during the product life cycle.

WEEE compliance may not be required in your location for electrical & electronic equipment (EEE), nor may it be required for EEE designed and intended as fixed or temporary installation in transportation vehicles such as automobiles, aircraft, and boats. In some European Union member states, these vehicles are considered outside of the scope of the Directive, and EEE for those applications can be considered excluded from the WEEE Directive requirement.

This symbol (WEEE wheelie bin) on product indicates the product must not be disposed of with other household refuse. It must be disposed of and collected for recycling and recovery of waste EEE. Johnson Outdoors Inc. will mark all EEE products in accordance with the WEEE Directive. It is our goal to comply in the collection, treatment, recovery, and environmentally sound disposal of those products; however, these requirements do vary within European Union member states. For more information about where you should dispose of your waste equipment for recycling and recovery and/or your European Union member state requirements, please contact your dealer or distributor from which your product was purchased.

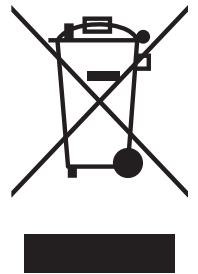

## DISPOSAL

Minn Kota motors are not subject to the disposal regulations EAG-VO (electric devices directive) that implements the WEEE directive. Nevertheless never dispose of your Minn Kota motor in a garbage bin but at the proper place of collection of your local town council.

Never dispose of battery in a garbage bin. Comply with the disposal directions of the manufacturer or his representative and dispose of them at the proper place of collection of your local town council.

## COMPLIANCE STATEMENTS

---

### FCC COMPLIANCE

This device complies with Part 15 of the FCC rules.

**Operation is subject to the following two conditions:**

1. This device may not cause harmful interference.
2. This device must accept any interference that may be received, including interference that may cause undesired operation.

Changes or modifications not expressly approved by Johnson Outdoors Marine Electronics, Inc. could void the user's authority to operate this equipment.

**NOTE:** This equipment has been tested and found to comply with the limits for a Class B digital device, pursuant to part 15 of the FCC Rules. These limits are designed to provide reasonable protection against harmful interference in a residential installation. This equipment generates, uses and can radiate radio frequency energy and, if not installed and used in accordance with the instructions, may cause harmful interference to radio communications. However, there is no guarantee that interference will not occur in a particular installation. **If this equipment does cause harmful interference to radio or television reception, which can be determined by turning the equipment off and on, the user is encouraged to try to correct the interference by one or more of the following measures:**

- Reorient or relocate the receiving antenna.
- Increase the separation between the equipment and receiver.
- Connect the equipment into an outlet on a circuit different from that to which the receiver is connected.
- Consult the dealer or an experienced radio/TV technician for help.

### INDUSTRY CANADA COMPLIANCE

This product meets the applicable Industry Canada technical specifications. Operation is subject to the following two conditions: (1) this device may not cause interference, and (2) this device must accept any interference, including interference that may cause undesired operation of the device.

Changes or modifications not expressly approved by Johnson Outdoors Marine Electronics, Inc. could void the user's authority to operate this equipment.

### ENVIRONMENTAL RATINGS

Ambient operating temperature range: -10C to 50C

Ambient operating humidity range: 5% to 95%

Maximum operating altitude: 10,000 feet



# PARTS DIAGRAM & PARTS LIST

## POWERDRIVE & RIPTIDE POWERDRIVE FOOT PEDAL Foot Pedal Parts Diagram

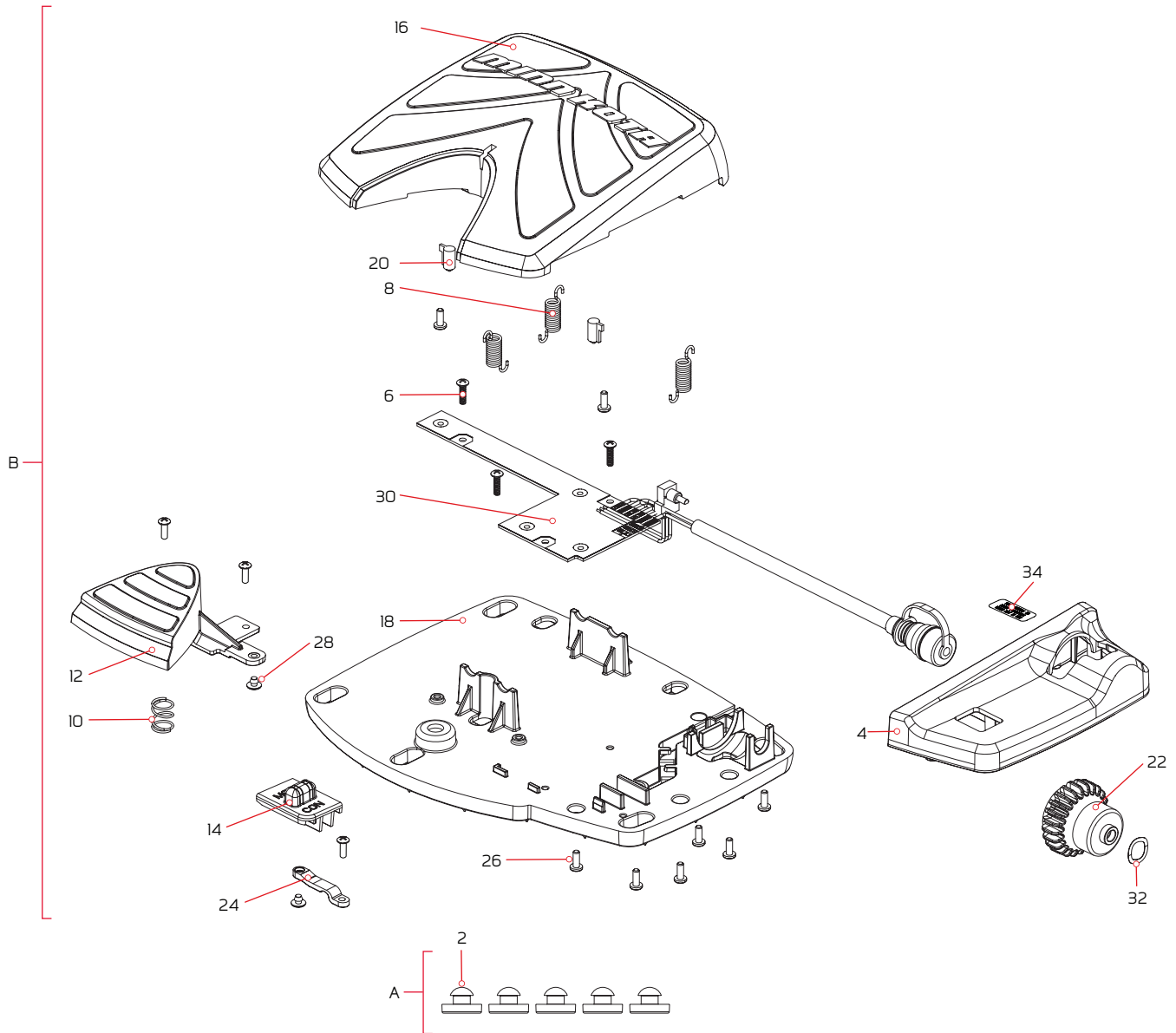

---

## Foot Pedal Parts List

Assembly	Part #	Description	Quantity
A	2994859	BAG ASY-TERROVA/V2,RUB.BUMPERS	1
B	2994727	FOOT PEDAL ASSEMBLY, PD	1
Item	Part #	Description	Quantity
1	2377167 ▲	MANUAL-FT PEDAL, POWERDRIVE V3	1
2	2325110	PAD, FOOT PEDAL PD	5
4	2300275	COVER-SPEED SELECTOR,PD FP,BLK	1
6	2302100	SCREW-#6-20 X 1/2 THD CUTS	3
8	2302730	SPRING-LONG-UPPER PEDAL [A118	3
10	2302732	SPRING-LOWER PEDAL S/S [A120	1
12	2303725	BUTTON-MOMENTARY, PD FP, BLK	1
14	2303730	BUTTON-MOM/CON, PD FP, BLK	1
16	2304405	PEDAL, STRG ROCKER, PD FP, BLK	1
18	2304508	BASE, PEDAL PD	1
20	2305136	BUMPER,STRG RCKR,PD FP,RUBBER	2
22	2307905	WHEEL-SPEED, PD FP, BLK	1
24	2308609	SWITCH LEVER, SINGLE	1
26	2332103	SCREW-#6-20 X 3/8 THD*(SS)	11
28	2335130	BUMBER ACTUATOR	2
30	✘	PCB/CTRL CORD, PD FT PEDAL	1
32	2301750	WASHER, WAVE, PD V3 FP	1
34	2316600	DECAL-ON/OFF SWITCH/PD V2 PED	1

✘ This part is included in an assembly and cannot be ordered individually.

▲ Not shown on Parts Diagram.

# RECOMMENDED ACCESSORIES

---

## ON-BOARD & PORTABLE BATTERY CHARGERS

**Stop buying new batteries and start taking care of the ones you've got.** Many chargers can actually damage your battery over time – creating shorter run times and shorter overall life. Digitally controlled Minn Kota chargers are designed to provide the fastest charge that protect and extend battery life.



MK212PC



MK210D



MK110P

---

## TALON SHALLOW WATER ANCHOR

Talon deploys faster, holds stronger and runs quieter than any other shallow water anchor. Available in depths up to 12' and bold color options including camo, it boasts an arsenal of features and innovations that no other anchor can touch:



- Vertical, Multi-Stage Deployment
  - User-Selectable Anchoring Modes
  - 2x Anchoring Force
  - Fast Deploy
  - Auto Up/Down
  - Triple Debris Shields
  - Built-In Wave Absorption
  - Noise Dissipation
  - Versatile Adjustments
- 

## MINN KOTA ACCESSORIES

We offer a wide variety of trolling motor accessories, including:



- 60-Amp Circuit Breaker
- Mounting Brackets
- Stabilizer Kits
- Extension Handles
- Battery Connectors
- Battery Boxes
- Quick Connect Plugs

Rely only on high-grade boat motors offered on our virtual shelves.