

RIPTIDE TRANSOM

TRANSOM-MOUNT TROLLING MOTOR

USER MANUAL

FEATURES

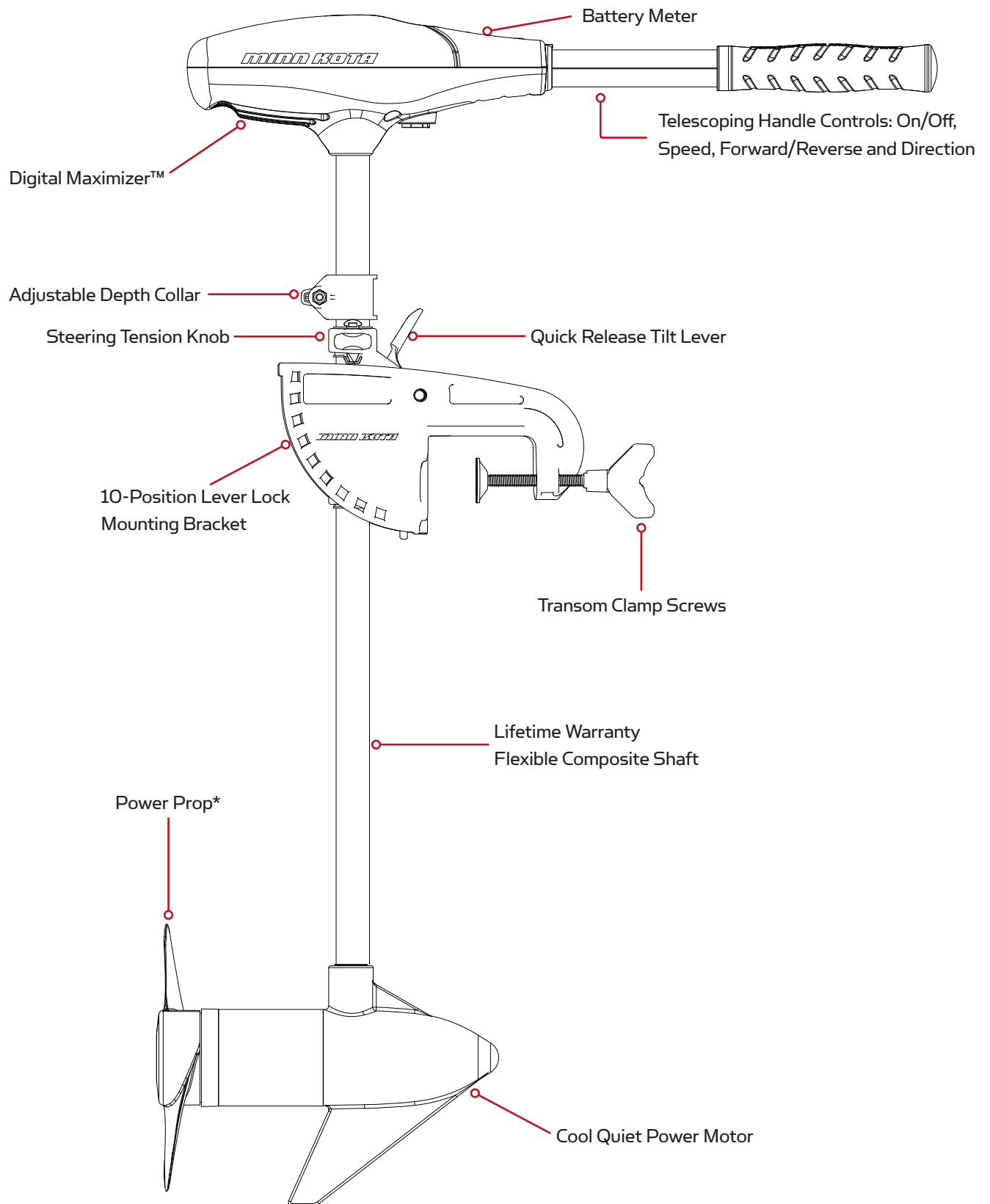

Specifications subject to change without notice.

*This diagram is for reference only and may differ from your actual motor.

INSTALLATION

HANDLE INSTALLATION

1. Remove the wire clip from the ball detent located on the inner handle.
2. Install outer handle over inner handle. Position the handles so the ball detent and OFF are aligned.
3. Push the outer handle into the control box until handle “clicks” into place. The handle is held in place with locking fingers, so some force may be required to lock the handles together.
4. Once the handle is locked into the control box, it can be rotated and extended for normal use.
5. Once the handle is installed, the assembly is permanent. Do not attempt to remove the handle.

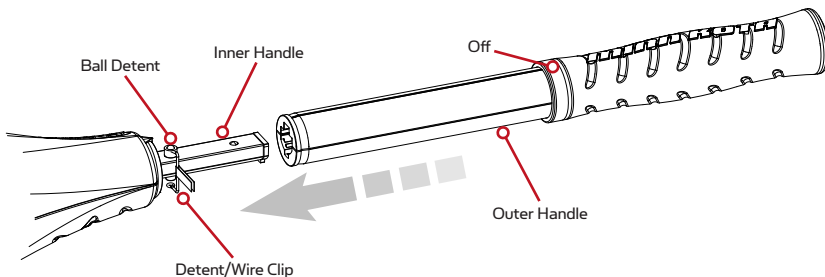

MOTOR INSTALLATION

1. Find a transom area of the boat that is free from obstructions.
2. Open the clamp screws on the bracket enough so that it will fit over the top of the boat transom.
3. Place the Lever Lock Mounting bracket over the top of the boat transom so that the bracket is resting on top of the transom.
4. Verify that there are no obstacles that the control box, handle, or prop might hit while in use that would restrict steering or cause damage to the motor.
5. Tighten down the clamp screws to the transom by hand only. Do not use any tools to tighten the clamp screws as this may damage the bracket or your boat.
6. We recommend the tilt angle of the motor to be adjusted so that the motor shaft is perpendicular to the water surface when the motor is in use.
7. For transport, always tilt the motor into the boat, such that the motor and prop assembly are completely out of the water and the motor is positioned up close to the lever lock bracket.

NOTE: When setting the depth be sure the top of the motor is submerged at least 12" to avoid churning or agitation of surface water. The propeller must be completely submerged.

CAUTION:

- **Never operate your motor when it is out of the water.**
- **Over-tightening the clamp screws can damage the bracket.**

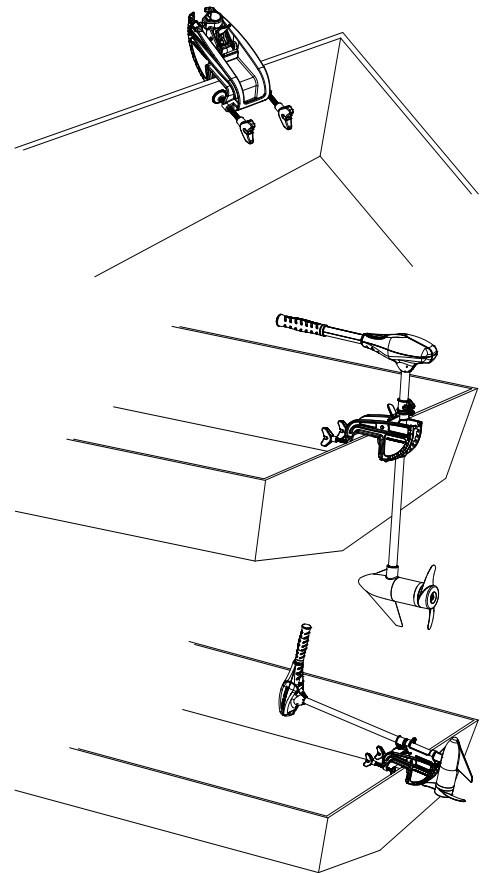

BATTERY WIRING & INSTALLATION

BOAT RIGGING & PRODUCT INSTALLATION

For safety and compliance reasons, we recommend that you follow American Boat and Yacht Council (ABYC) standards when rigging your boat. Altering boat wiring should be completed by a qualified marine technician. The following specifications are for general guidelines only:

CAUTION: These guidelines apply to general rigging to support your Minn Kota motor. Powering multiple motors or additional electrical devices from the same power circuit may impact the recommended conductor gauge and circuit breaker size. If you are using wire longer than that provided with your unit, follow the conductor gauge and circuit breaker sizing table below. If your wire extension length is more than 25 feet, we recommend that you contact a qualified marine technician.

An over-current protection device (circuit breaker or fuse) must be used. Coast Guard requirements dictate that each ungrounded current-carrying conductor must be protected by a manually reset, trip-free circuit breaker or fuse. The type (voltage and current rating) of the fuse or circuit breaker must be sized accordingly to the trolling motor used. The table below gives recommended guidelines for circuit breaker sizing.

Reference:

United States Code of Federal Regulations: 33 CFR 183 – Boats and Associated Equipment
 ABYC E-11: AC and DC Electrical Systems on Boats

CONDUCTOR GAUGE AND CIRCUIT BREAKER SIZING TABLE

Motor Thrust / Model	Max Amp Draw	Circuit Breaker	Wire Extension Length *				
			5 feet	10 feet	15 feet	20 feet	25 feet
30 lb.	30	50 Amp @ 12 VDC	10 AWG	10 AWG	8 AWG	6 AWG	4 AWG
40 lb., 45 lb.	42		10 AWG	8 AWG	6 AWG	4 AWG	4 AWG
50 lb., 55 lb.	50	60 Amp @ 12 VDC	8 AWG	6 AWG	4 AWG	4 AWG	2 AWG
70 lb.	42	50 Amp @ 24 VDC	10 AWG	10 AWG	8 AWG	8 AWG	6 AWG
80 lb.	56	60 Amp @ 24 VDC	8 AWG	8 AWG	8 AWG	6 AWG	6 AWG
101 lb.	46	50 Amp @ 36 VDC	8 AWG	8 AWG	8 AWG	8 AWG	8 AWG
Engine Mount 101	50	60 Amp @ 36 VDC	8 AWG	6 AWG	4 AWG	4 AWG	2 AWG
112 lb.	52	60 Amp @ 36 VDC	8 AWG	8 AWG	8 AWG	8 AWG	8 AWG
Engine Mount 160	116	(2) x 60 Amp @ 24 VDC	2 AWG	2 AWG	2 AWG	2 AWG	2 AWG
E-Drive	40	50 Amp @ 48 VDC	10 AWG	10 AWG	10 AWG	10 AWG	10 AWG

This conductor and circuit breaker sizing table is only valid for the following assumptions:

1. No more than 3 conductors are bundled together inside of a sheath or conduit outside of engine spaces.
2. Each conductor has 105° C temp rated insulation.
3. No more than 5% voltage drop allowed at full motor power based on published product power requirements.

***Wire Extension Length refers to the distance from the batteries to the trolling motor leads.**

BATTERY WIRING & INSTALLATION

SELECTING THE CORRECT BATTERIES

The motor will operate with any lead acid, deep cycle marine 12 volt battery/batteries. For best results, use a deep cycle, marine battery with at least a 105 ampere hour rating. Maintain battery at full charge. Proper care will ensure having battery power when you need it, and will significantly improve the battery life. Failure to recharge lead-acid batteries (within 12-24 hours) is the leading cause of premature battery failure. Use a multi-stage charger to avoid overcharging. We offer a wide selection of chargers to fit your charging needs. If you are using a crank battery to start a gasoline outboard, we recommend that you use a separate deep cycle marine battery/batteries for your Minn Kota trolling motor.

Advice Regarding Batteries:

- Never connect the (+) and the (-) terminals of the battery together. Take care that no metal object can fall onto the battery and short the terminals. This would immediately lead to a short and extreme fire danger.
- It is highly recommended that a circuit breaker or fuse be used with this trolling motor. Refer to “Conductor Gauge and Circuit Breaker Sizing Table” in the previous section to find the appropriate circuit breaker or fuse for your motor. For motors requiring a 60-amp breaker, the Minn Kota MKR-19 60-amp circuit breaker is recommended.

CONNECTING THE BATTERIES

12 VOLT SYSTEMS:

1. Make sure that the motor is switched off (speed selector on “OFF” or “0”).
2. Connect positive (+) red lead to positive (+) battery terminal.
3. Connect negative (-) black lead to negative (-) battery terminal.
4. For safety reasons do not switch the motor on until the propeller is in the water.

CAUTION:

For safety reasons, disconnect the motor from the battery/batteries when the motor is not in use or while the battery/batteries are being charged.

PUSH-TO-TEST BATTERY METER

This motor is equipped with a “push to test” battery meter. The LED provides an accurate display of the remaining charge in the battery. It is only accurate when the motor is off.

The meter reads as:

- One light indicates recharge.
- Two lights indicate low charge.
- Three lights indicate good charge.
- Four lights indicate full charge.

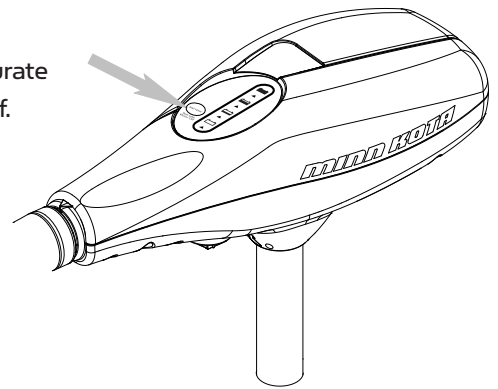

MOTOR WIRING DIAGRAM

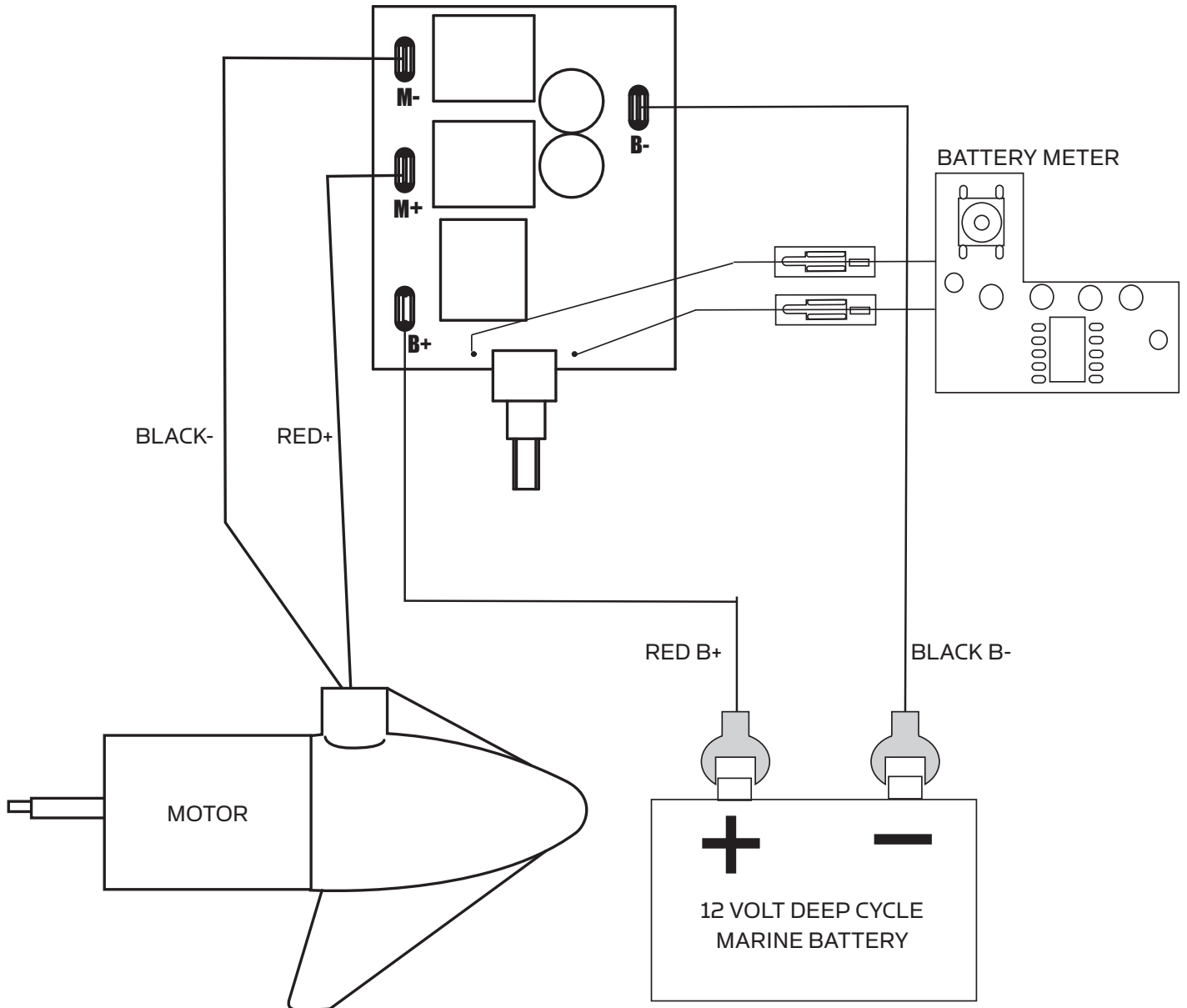

USING & ADJUSTING THE MOTOR

ADJUSTING THE DEPTH OF THE MOTOR

When setting the depth be sure the top of the motor is submerged at least 12" to avoid churning or agitation of surface water. The propeller must be completely submerged.

1. Firmly grasp the composite shaft and hold it steady.
2. Loosen the steering tension knob and depth collar knob until the shaft slides freely.
3. Raise or lower the motor to the desired depth.
4. Tighten depth collar knob to secure the motor in place.

CAUTION:

- **Never operate your motor when it is out of the water.**
- **Over-tightening the clamp screws can damage the bracket.**

ADJUSTING THE STEERING

- Adjust the steering tension knob to provide enough tension to allow the motor to turn freely, yet remain in any position without being held

OR

- Tighten the knob to place the motor in a preset position to leave your hands free for fishing.

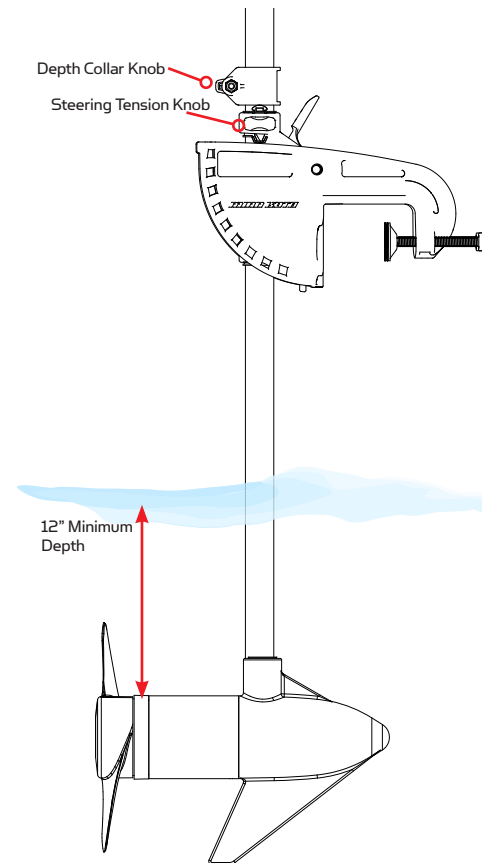

CONTROLLING SPEED AND DIRECTION WITH THE TILLER:

These motors are equipped with an extension twist tiller with a telescoping handle, which offers variable forward and reverse speeds. The speed control may be operated in either direction, forward or reverse. Turn the tiller handle counterclockwise from (OFF) to increase reverse speed and clockwise from (OFF) to increase forward speed. Thrust decreases as you approach (OFF) from either direction.

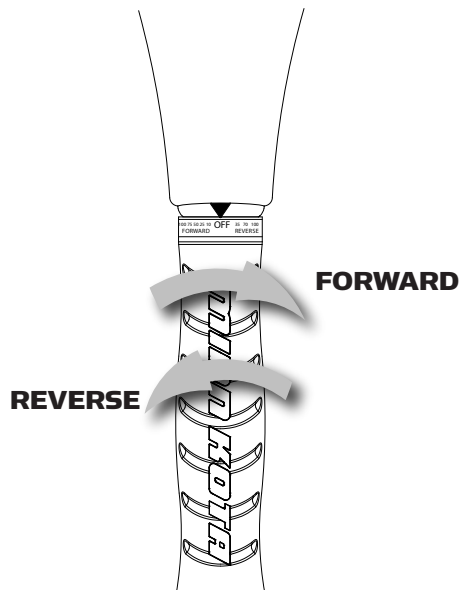

ADJUSTING THE BRACKET

You can lock your motor in a vertical position, angle it for shallow water or tilt it completely out of the water.

1. Firmly grasp the control head or composite shaft.
2. Press the tilt lever toward the shaft and hold to release the detent lock or T-bar to adjust the position of the mounting bracket.
3. Tilt to any of the positions on the mounting bracket.
4. Release the tilt lever.

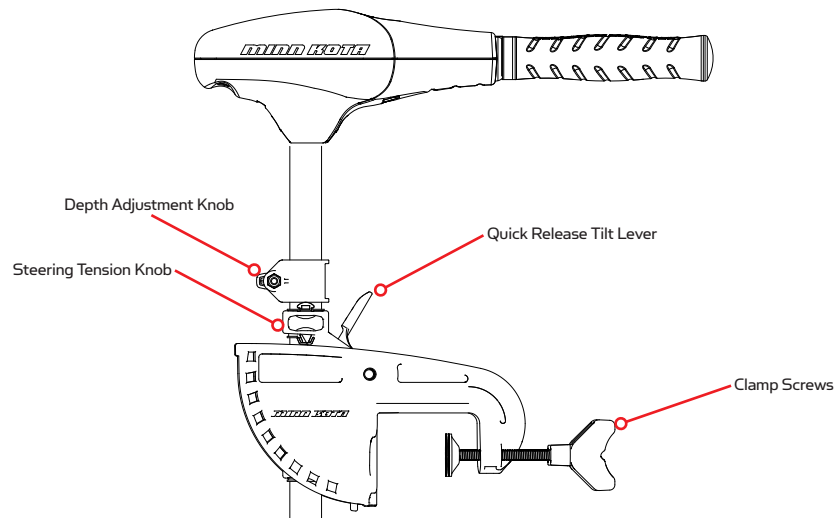

STOWING THE MOTOR

1. Adjust depth so that the motor is fully raised.
2. Press and hold tilt lever.
3. Tilt motor into the boat.
4. For transport, always tilt the motor into the boat such that the motor and prop assembly are completely out of the water and the motor is positioned up close to the lever lock bracket.

WARNING: When raising/lowering motor or operating the tilt mechanism, keep fingers clear of all hinge and pivot points and all moving parts.

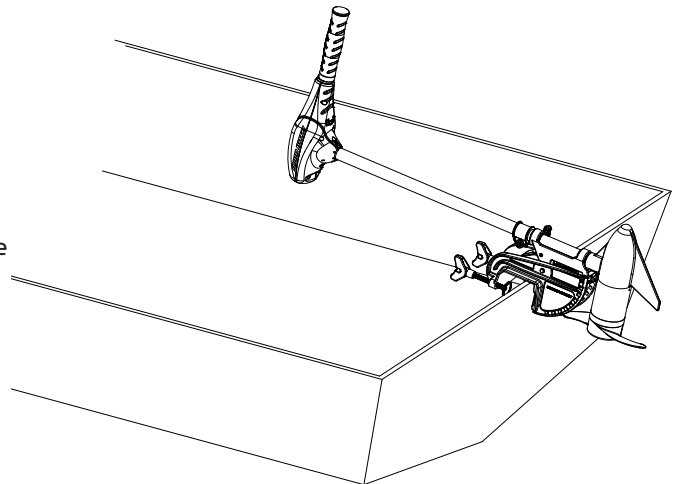

SERVICE & MAINTENANCE

PROPELLER REPLACEMENT

TOOLS AND RESOURCES REQUIRED:

- Box End Wrench
 - 1/2" for motors with 70 lbs thrust or lower.
 - 9/16" for motors with 80 lbs thrust or higher.
- Screwdriver (optional)

CAUTION:

Disconnect the motor from the battery before beginning any prop work or maintenance.

NOTE: The propeller on your motor may differ from the one pictured.

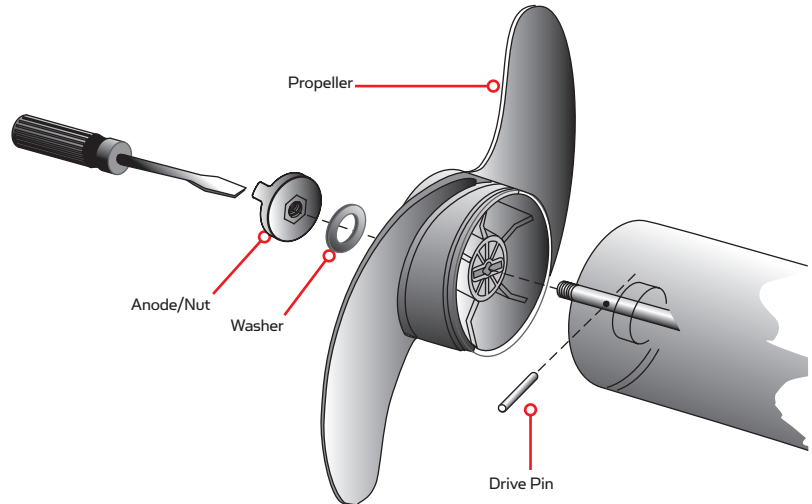

1. Disconnect motor from battery prior to changing the propeller.
2. Hold the propeller and loosen the anode/nut with a wrench.
3. Remove anode/nut and washer. If the drive pin is sheared/broken, you will need to hold the shaft steady with a screwdriver blade pressed into the slot on the end of the shaft.
4. Turn the old prop to horizontal (as illustrated) and pull it straight off. If drive pin falls out, push it back in.
5. Align new propeller with drive pin.
6. Install prop washer and anode/nut.
7. Tighten anode/ nut 1/4 turn past snug. [25-35 inch lbs.] Be careful, over tightening can damage prop.

GENERAL MAINTENANCE

1. After use, the entire motor should be rinsed with freshwater, then wiped down with a cloth dampened with an aqueous based silicone spray.
2. The propeller must be inspected and cleaned of weeds and fishing line after every use. Fishing line and weeds can get behind the prop, damage the seals and allow water to enter the motor.
3. Verify the prop nut is secure each time the motor is used.
4. To prevent accidental damage during transportation or storage, disconnect the battery whenever the motor is off of the water. For prolonged storage, lightly coat all metal parts with an aqueous based silicone spray.
5. For maximum battery life, recharge the battery(s) as soon as possible after use. For maximum motor performance, restore battery to full charge prior to use.
6. Keep battery terminals clean with fine sandpaper or emery cloth.
7. The propeller is designed to provide optimum operation with very high efficiency. To maintain this top performance, the leading edge of the blades must be kept smooth. If they are rough or nicked from use, restore to smooth by sanding with fine sandpaper.

TROUBLESHOOTING & REPAIR

1. Motor fails to run or lacks power:
 - Check battery connections for proper polarity.
 - Make sure terminals are clean and corrosion free. Use fine sandpaper or emery cloth to clean terminals.
 - Check battery water level. Add water if needed.
2. Motor loses power after a short running time:
 - Check battery charge. If low, restore to full charge.
3. Motor is difficult to steer:
 - Loosen the steering tension knob on the bracket
 - Lubricate the composite shaft.
4. You experience prop vibration during normal operation:
 - Remove and rotate the prop 180°. See removal instructions in the Propeller Replacement section.
5. Experiencing interference with your fishfinder:

PARTS DIAGRAM

RIPTIDE TRANSOM 55 V/T 55 LBS THRUST - 12 VOLT - 36"/42" SHAFT

This page provides Minn Kota® WEEE compliance disassembly instructions. For more information about where you should dispose of your waste equipment for recycling and recovery and/or your European Union member state requirements, please contact your dealer or distributor from which your product was purchased.

Tools required, but not limited to: flat head screw driver, Phillips screw driver, socket set, pliers, wire cutters.

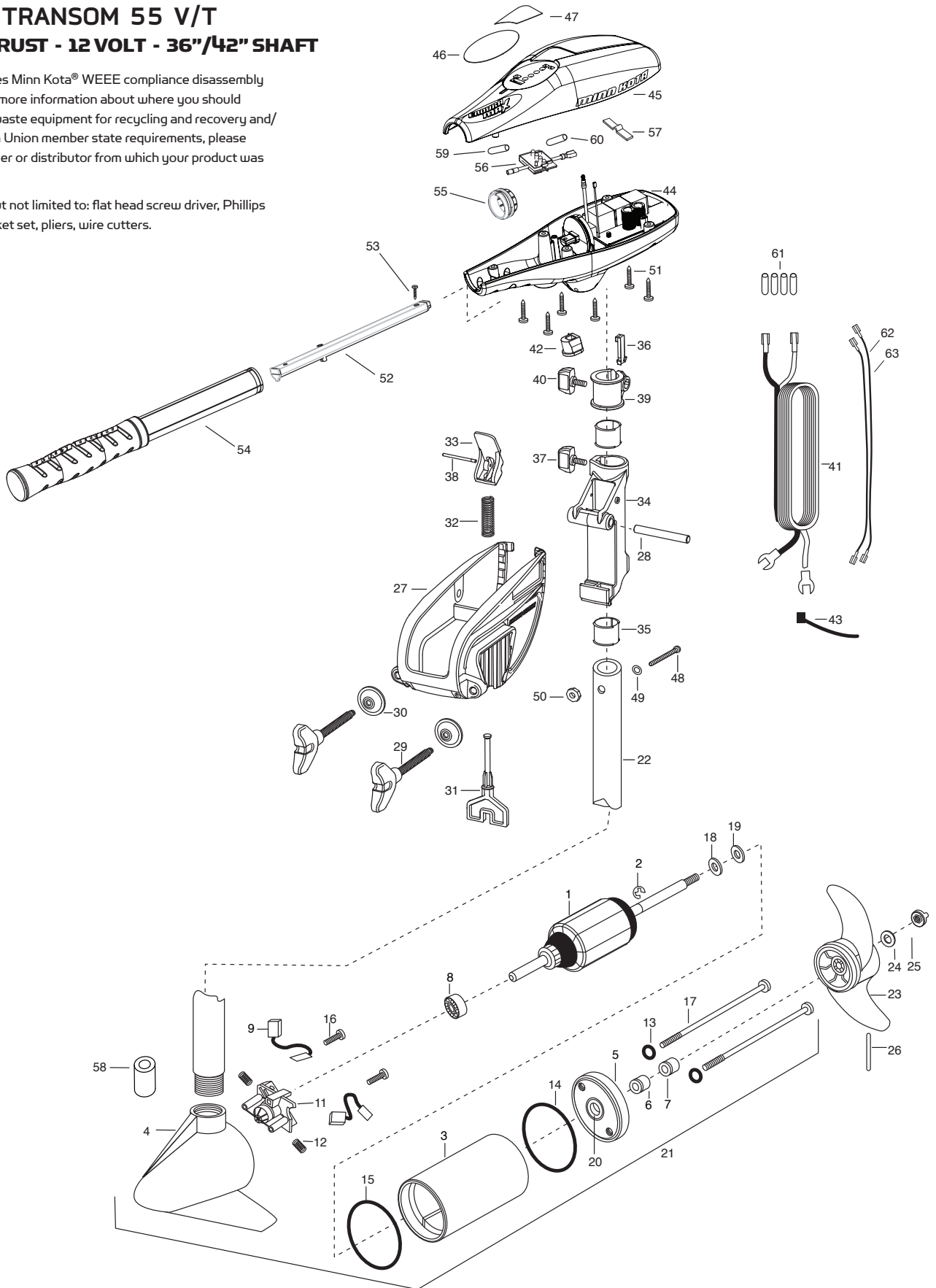

PARTS LIST

RIPTIDE TRANSOM 55 V/T 55 LBS THRUST - 12 VOLT - 36"/42" SHAFT

ITEM	QTY	PART NUMBER	DESCRIPTION
1	1	2-100-117	ARMATURE ASSEMBLY 12V 3.62
2	1	788-015	RETAINING RING
3	1	2-200-301	HOUSING ASSEMBLY CENTER 3.62 SW
4	1	421-336	BRUSH END HOUSING ASSEMBLY 3.62
5	1	2-400-337	PLAIN END HOUSING ASSEMBLY 3.62
6	1	880-003	SEAL
7	1	880-006	SEAL W/SHIELD
8	1	140-010	BALL BEARING
9	2	188-036	BRUSH ASSEMBLY
11	1	738-036	BRUSH PLATE W/HOLDER 3.62
12	2	975-040	TORSION SPRING
■	1	2888460	SEAL AND O-RING KIT
13	2	701-008	O-RING -- THRU BOLT
14	1	701-081	O-RING
15	1	337-036	GASKET
16	2	830-007	SCREW -- SELF THREAD #8-32
17	2	830-042	THRU BOLT #10-32 X 8.83
18	1	990-067	WASHER -- STEEL THRUST
19	1	990-070	WASHER -- NYLATRON
20	1	144-049	FLANGE BEARING (SERVICE ONLY)
21	1	2097078	MOTOR ASSEMBLY 12 V 3.62 SW 36"
	1	2097093	MOTOR ASSEMBLY 12 V 3.62 SW 42"
22	1	2002021	36" COMPOSITE TUBE
	1	2002022	42" COMPOSITE TUBE
■	1	1378170	PROPELLER KIT
23	1	2091170	PROPELLER 3.62 HUB DIA
24	1	2151726	WASHER -- 5/16 STD SS
25	1	2198400	ZINC ANODE
26	1	2092600	DRIVE PIN
■	1	2771816	BRACKET & HINGE ASSEMBLY (INCLUDES 27-38)
■	1	2771913	BRACKET ASSEMBLY (INCLUDES 27, 29, 30)
*27	1	2061910	BRACKET
28	1	2060511	HINGE PIN
*29	2	2061301	SCREW -- CLAMP

ITEM	QTY	PART NUMBER	DESCRIPTION
*30	2	2331700	WASHER -- CLAMP SCREW
31	1	2063605	PLASTIC T-BAR
32	1	2062706	T-BAR SPRING
33	1	2067201	TILT BLACK LEVER
34	1	2061810	PLASTIC HINGE
35	2	2037301	HINGE BUSHING
36	1	2062800	SNAP-IN TENSION BLOCK
37	1	2011386	SCREW -- TENSION/KNOB
38	1	2060516	TILT LEVER PIN
39	1	2061520	DEPTH COLLAR
40	1	2011366	SCREW -- COLLAR/NEW KNOB
41	1	2050609	LEADWIRE
42	1	2062905	STRAIN RELIEF
43	1	2376312	TIE WRAP
44	1	2994041	CONTROL BOX WHITE
45	1	2060226	CONTROL BOX COVER WHITE
46	1	2095635	DECAL COVER RIPTIDE 55 VS/T
47	1	2095636	COVER DECAL, RT/VS/T
48	1	2033403	SCREW-10-24 X 1-3/4, SS
49	1	2061720	WASHER-NYLON, 3/8 OD, 3/16 ID
50	1	2333101	NUT-10-24 HEX, SS
51	6	2372100	SCREW-8-18 X 5/8, SS
52	1	2990924	INNER HANDLE ASSEMBLY
53	1	2012104	SCREW-#6 X 1/2" SS
54	1	2990952	OUTER HANDLE ASSEMBLY
55	1	2060009	FRONT BEARING
56	1	2074080	BATTERY METER 12V
57	1	2302742	SPRING DETENT, OFF
58	1	2307312	FERRITE BEAD
59	1	2305415	SHRINK TUBE - .472 ID X 2.25"
60	1	2305410	SHRINK TUBE - .315 OD X 2.25"
61	4	2305403	SHRINK TUBE - .500 ID 1.0" ADHSV
62	1	640-002	BLACK LEADWIRE
63	1	640-113	RED LEADWIRE

■ THIS ITEM IS PART OF AN ASSEMBLY.
*THIS ITEM IS PART OF A KIT AND ONLY LISTED FOR VIEWING PURPOSES.

COMPLIANCE STATEMENTS

ENVIRONMENTAL COMPLIANCE STATEMENT:

It is the intention of JOME to be a responsible corporate citizen, operating in compliance with known and applicable environmental regulations, and a good neighbor in the communities where we make or sell our products.

WEEE DIRECTIVE:

EU Directive 2002/96/EC "Waste of Electrical and Electronic Equipment Directive (WEEE)" impacts most distributors, sellers, and manufacturers of consumer electronics in the European Union. The WEEE Directive requires the producer of consumer electronics to take responsibility for the management of waste from their products to achieve environmentally responsible disposal during the product life cycle.

WEEE compliance may not be required in your location for electrical & electronic equipment (EEE), nor may it be required for EEE designed and intended as fixed or temporary installation in transportation vehicles such as automobiles, aircraft, and boats. In some European Union member states, these vehicles are considered outside of the scope of the Directive, and EEE for those applications can be considered excluded from the WEEE Directive requirement.

This symbol (WEEE wheelie bin) on product indicates the product must not be disposed of with other household refuse. It must be disposed of and collected for recycling and recovery of waste EEE. Johnson Outdoors Inc. will mark all EEE products in accordance with the WEEE Directive. It is our goal to comply in the collection, treatment, recovery, and environmentally sound disposal of those products; however, these requirements do vary within European Union member states. For more information about where you should dispose of your waste equipment for recycling and recovery and/or your European Union member state requirements, please contact your dealer or distributor from which your product was purchased.

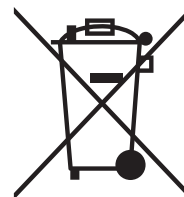

DISPOSAL:

Minn Kota motors are not subject to the disposal regulations EAG-VO (electric devices directive) that implements the WEEE directive. Nevertheless never dispose of your Minn Kota motor in a garbage bin but at the proper place of collection of your local town council.

Never dispose of battery in a garbage bin. Comply with the disposal directions of the manufacturer or his representative and dispose of them at the proper place of collection of your local town council.

WARNING: This product contains chemicals known to the State of California to cause cancer and birth defects or other reproductive harm.

RECOMMENDED ACCESSORIES

ON-BOARD & PORTABLE BATTERY CHARGERS

Stop buying new batteries and start taking care of the ones you've got. Many chargers can actually damage your battery over time – creating shorter run times and shorter overall life. Digitally controlled Minn Kota chargers are designed to provide the fastest charge that protect and extend battery life.



MK345PC



MK210D



MK110P

TALON SHALLOW WATER ANCHOR

Talon deploys faster, holds stronger and runs quieter than any other shallow water anchor. Available in depths up to 12' and bold color options, it boasts an arsenal of features and innovations that no other anchor can touch:



- Vertical, multi-stage deployment
- User-Selectable Anchoring Modes
- 2x Anchoring Force
- Fast Deploy
- Auto Up/Down
- Triple Debris shields*
- Built-In Wave Absorption
- Noise Dissipation
- Versatile Adjustments

*available on 10' and 12' models only

MINN KOTA ACCESSORIES

We offer a wide variety of trolling motor accessories, including:



- 60-Amp Circuit Breaker
- Mounting Brackets
- Stabilizer Kits
- Extension Handles
- Battery Connectors
- Battery Boxes
- Quick Connect Plugs

