

### Changes in topside tank configurations that you need to know going forward!!

The new EPA Evaporative Emissions Regulations require Moeller as a fuel tank manufacturer to make several changes to our above deck topside tanks above 12-gallon in capacity to accommodate boats built after 2011:

- Each Moeller tank must have a minimum of 5% of the inside volume reserved for ullage open headspace and thus a full fill line is molded in to each tank.
- Tank capacities now reflect the required inside 5% open headspace requirement for both EPA and non-EPA tank models.
- A NEW EPA compliant 2-stage "click when closed" fuel cap is required for the 'BR' (Barrier version) model tanks as well.
- The 'BR' (Barrier version) tanks are essentially pressured to a minimum of 5 lbs of internal pressure and as a normal process during the daily temperature fluctuations may swell or contract over a typical 24 hour span.
- Moeller utilizes the same mold lid/base for barrier and non-barrier versions thus we have had to install a 3" port in the center of the tank to allow for the barrier material to be loaded during production.
- Replacing the old style Kelch gauge/cap eliminates the ability to have a sight gauge on the barrier version models thus we install a 1-1/2" block off plate in the non-barrier version tank models so we can install a mechanical float gauge in the barrier version models.

The attached line drawings detail the changes we've had to make.

Above Deck Tanks in either number sequence will look exactly the same with the ports sealed at the factory.

All Moeller Above Deck tanks are pressure tested to a minimum of 3 lbs as required by law to eliminate leakage issues before being shipped.

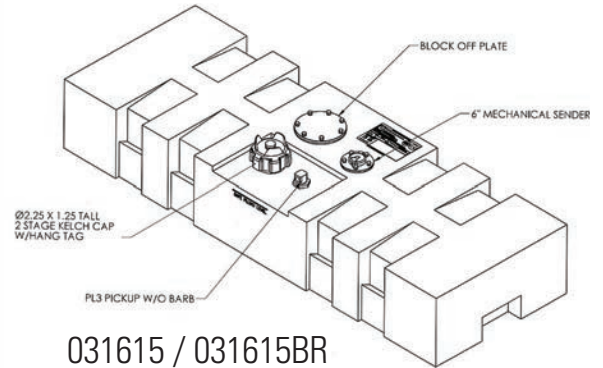

031615 / 031615BR

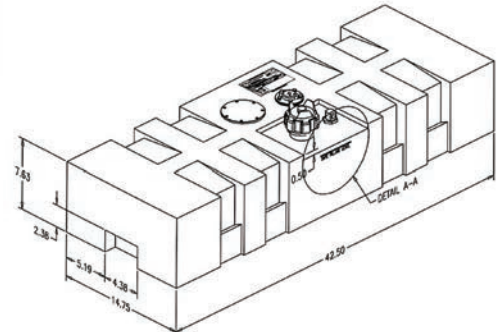

031818 / 031818BR

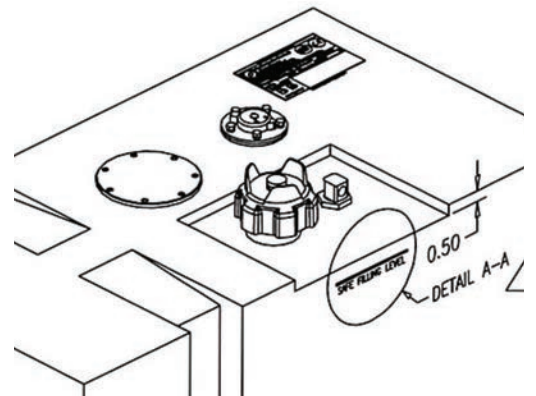

031620 / 031620BR

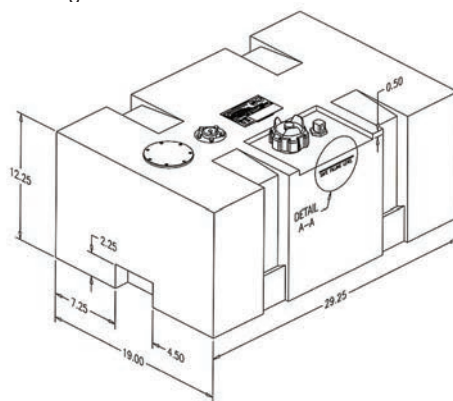

031526 / 031526BR

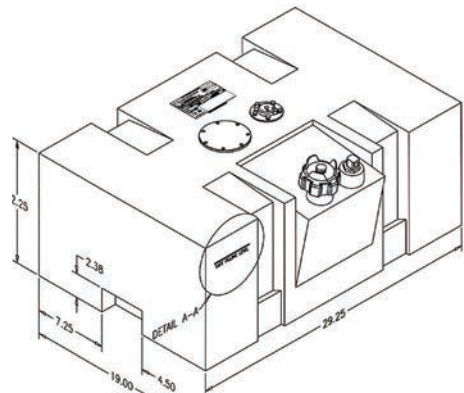

031626 / 031626BR