

## MORSE ARCH FENDER MA200

### Technical data

#### General description

Arch fenders provide a simple, efficient and robust fender at a low cost. The fenders do not require field assembly and can be supplied either in solid rubber or with an integrally bonded UHMW-PE top. Arch fenders can be mounted directly to the dock face, whether it be new or existing concrete or structural steel. The fender can be mounted in any direction; i.e. vertically, horizontally, or diagonally to provide the best coverage.

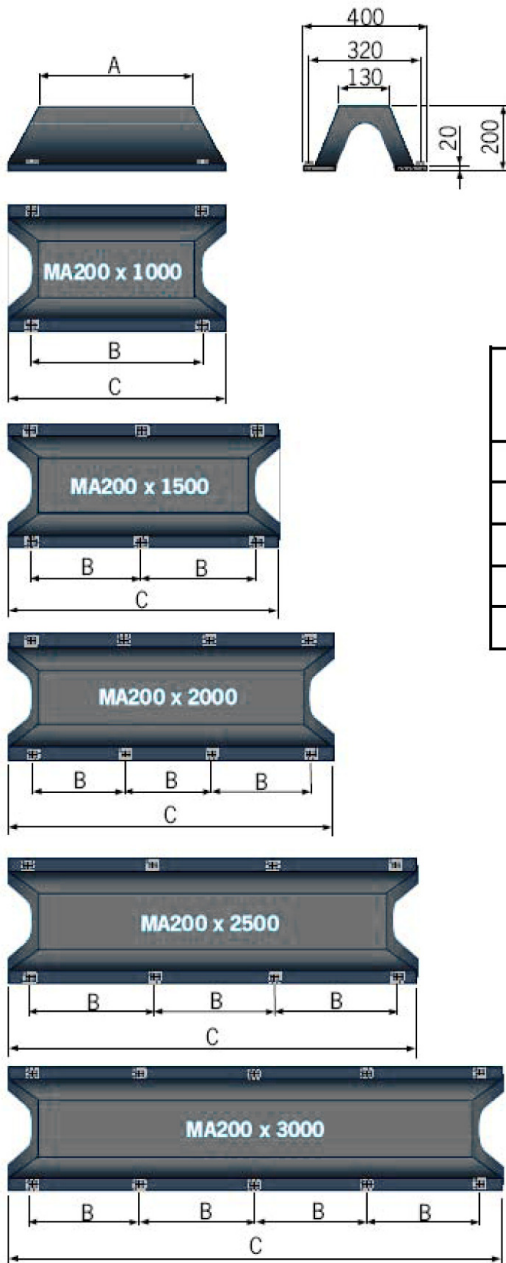

Arch fender	Dimensions			Anchor
	A	B	C	
MA200 x 1000	1000	900	1100	4 x M24
MA200 x 1500	1500	700	1600	6 x M24
MA200 x 2000	2000	630	2100	8 x M24
MA200 x 2500	2500	800	2600	8 x M24
MA200 x 3000	3000	725	3100	10 x M24

#### Performance

Arch fender	Deflection %	Energy absorption Tm	Reaction force T
MA200 x 1000B	52	0.8	10.4
MA200 x 1000A	52	1.2	15.4
MA200 x 1500B	52	1.2	16.0
MA200 x 1500A	52	1.7	22.8
MA200 x 2000B	52	1.6	21.1
MA200 x 2000A	52	2.3	30.1
MA200 x 2500B	52	2.0	26.3
MA200 x 2500A	52	2.9	37.6
MA200x 3000B	52	2.5	30.8
MA200 x 3000A	52	3.6	44.0

## ARCH FENDER MA250

### Technical data

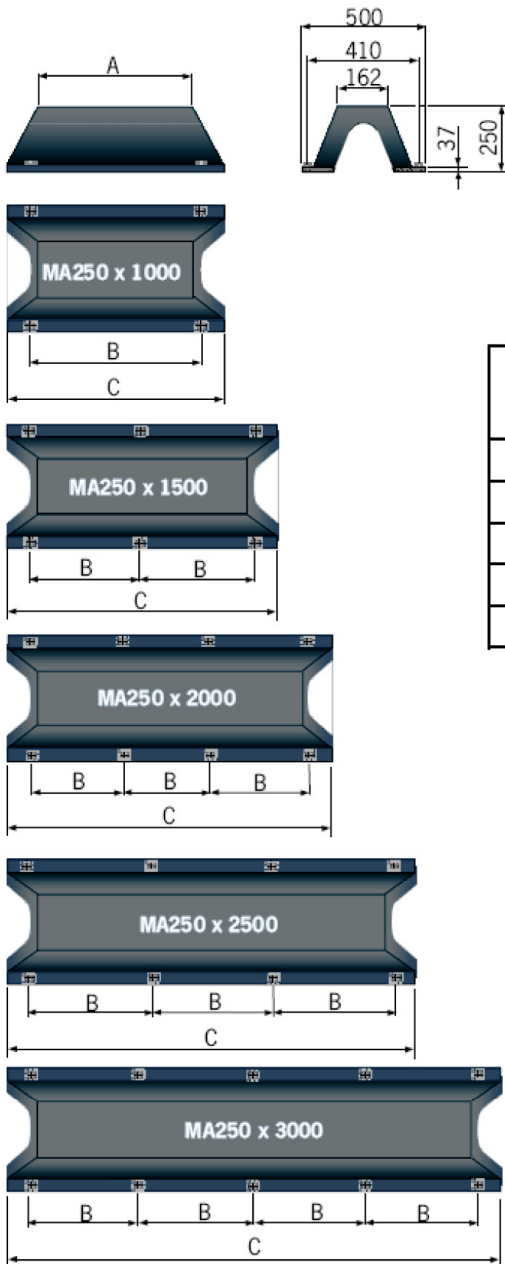

### General description

Arch fenders provide a simple, efficient and robust fender at a low cost. The fenders do not require field assembly and can be supplied either in solid rubber or with an integrally bonded UHMW-PE top. Arch fenders can be mounted directly to the dock face, whether it be new or existing concrete or structural steel. The fender can be mounted in any direction; i.e. vertically, horizontally, or diagonally to provide the best coverage.

Arch fender	Dimensions			Anchor
	A	B	C	
MA250 x 1000	1000	865	1125	4 x M24
MA250 x 1500	1500	680	1625	6 x M24
MA250 x 2000	2000	620	2125	8 x M24
MA250 x 2500	2500	790	2625	8 x M24
MA250 x 3000	3000	715	3125	10 x M24

### Performance

Arch fender	Deflection %	Energy absorption Tm	Reaction force T
MA250 x 1000B	52	1.2	12.0
MA250 x 1000A	52	1.7	17.1
MA250 x 1500B	52	1.8	17.6
MA250 x 1500A	52	2.6	25.2
MA250 x 2000B	52	2.4	23.2
MA250 x 2000A	52	3.4	33.2
MA250 x 2500B	52	2.9	28.9
MA250 x 2500A	52	4.2	41.3
MA250x 3000B	52	3.5	34.5
MA250 x 3000A	52	5.0	49.3

## ARCH FENDER MA300

### Technical data

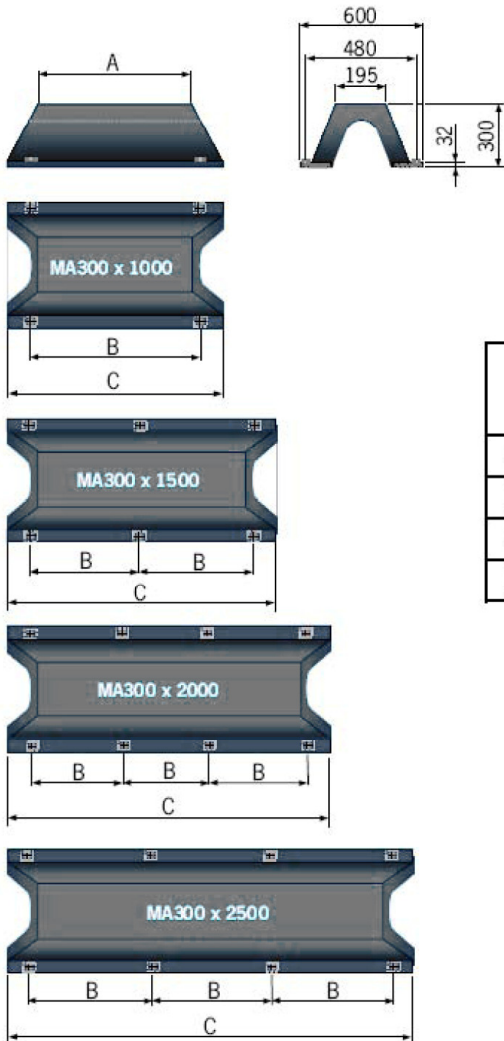

### General description

Arch fenders provide a simple, efficient and robust fender at a low cost. The fenders do not require field assembly and can be supplied either in solid rubber or with an integrally bonded UHMW-PE top. Arch fenders can be mounted directly to the dock face, whether it be new or existing concrete or structural steel. The fender can be mounted in any direction; i.e. vertically, horizontally, or diagonally to provide the best coverage.

Arch fender	Dimensions			Anchor
	A	B	C	
MA300 x 1000	1000	900	1150	4 x M30
MA300 x 1500	1500	700	1650	6 x M30
MA300 x 2000	2000	630	2150	8 x M30
MA300 x 2500	2500	800	2650	8 x M30

### Performance

Arch fender	Deflection %	Energy absorption Tm	Reaction force T
MA300 x 1000B	52	2.0	16.2
MA300 x 1000A	52	2.8	23.2
MA300 x 1500B	52	2.9	23.9
MA300 x 1500A	52	4.2	34.1
MA300 x 2000B	52	3.9	31.4
MA300 x 2000A	52	5.5	44.9
MA300 x 2500B	52	4.8	39.0
MA300 x 2500A	52	6.8	55.7

TL16EN213

## ARCH FENDER MA400

### Technical data

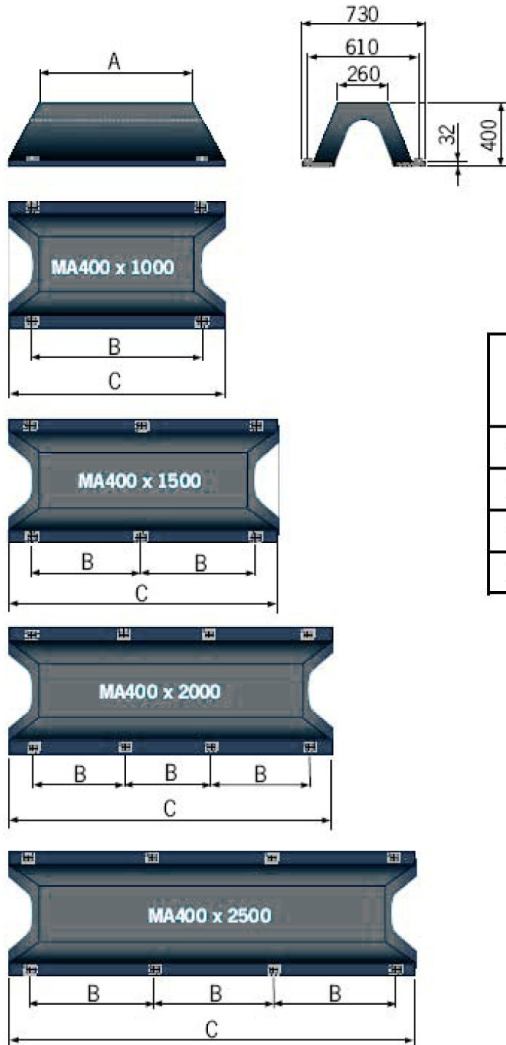

### General description

Arch fenders provide a simple, efficient and robust fender at a low cost. The fenders do not require field assembly and can be supplied either in solid rubber or with an integrally bonded UHMW-PE top. Arch fenders can be mounted directly to the dock face, whether it be new or existing concrete or structural steel. The fender can be mounted in any direction; i.e. vertically, horizontally, or diagonally to provide the best coverage.

Arch fender	Dimensions			Anchor
	A	B	C	
MA400 x 1000	1000	900	1200	4 x M30
MA400 x 1500	1500	700	1700	6 x M30
MA400 x 2000	2000	630	2200	8 x M30
MA400 x 2500	2500	800	2700	8 x M30

### Performance

Arch fender	Deflection %	Energy absorption Tm	Reaction force T
MA400 x 1000B	52	3.6	22.2
MA400 x 1000A	52	5.2	31.7
MA400 x 1500B	52	5.3	32.3
MA400 x 1500A	52	4.2	34.1
MA400 x 2000B	52	6.9	42.4
MA400 x 2000A	52	9.9	60.5
MA400 x 2500B	52	8.6	52.4
MA400 x 2500A	52	12.3	74.9

TL16EN214

## ARCH FENDER MA500

### Technical data

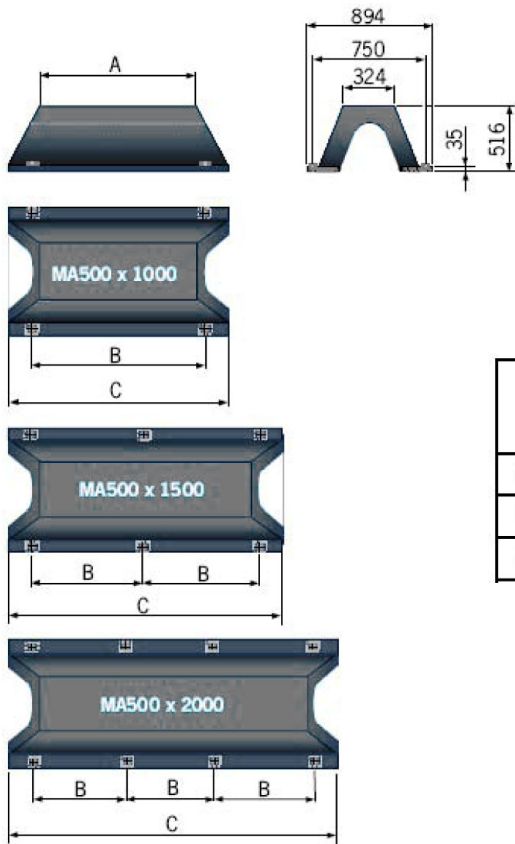

### General description

Arch fenders provide a simple, efficient and robust fender at a low cost. The fenders do not require field assembly and can be supplied either in solid rubber or with an integrally bonded UHMW-PE top. Arch fenders can be mounted directly to the dock face, whether it be new or existing concrete or structural steel. The fender can be mounted in any direction; i.e. vertically, horizontally, or diagonally to provide the best coverage.

Arch fender	A	B	C	Anchor
MA500 x 1000	1000	900	1250	4 x M36
MA500 x 1500	1500	700	1750	6 x M36
MA500 x 2000	2000	630	2250	8 x M36

### Performance

Arch fender	Deflection %	Energy absorption Tm	Reaction force T
MA500 x 1000B	52	5.8	28.4
MA500 x 1000A	52	8.3	40.5
MA500 x 1500B	52	8.4	41.0
MA500 x 1500A	52	12.0	58.6
MA500 x 2000B	52	11.0	53.6
MA500 x 2000A	52	15.7	76.5

## ARCH FENDER MA600

### Technical data

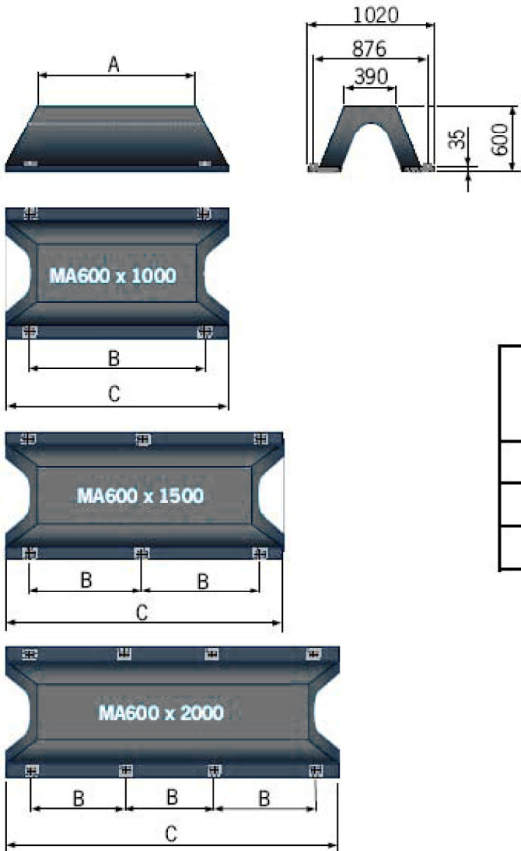

### General description

Arch fenders provide a simple, efficient and robust fender at a low cost. The fenders do not require field assembly and can be supplied either in solid rubber or with an integrally bonded UHMW-PE top. Arch fenders can be mounted directly to the dock face, whether it be new or existing concrete or structural steel. The fender can be mounted in any direction; i.e. vertically, horizontally, or diagonally to provide the best coverage.

Arch fender	Dimensions			Anchor
	A	B	C	
MA600 x 1000	1000	900	1300	4 x M36
MA600 x 1500	1500	700	1800	6 x M36
MA600 x 2000	2000	630	2300	8 x M36

### Performance

Arch fender	Deflection %	Energy absorption Tm	Reaction force T
MA600 x 1000B	52	8.5	34.8
MA600 x 1000A	52	12.2	49.7
MA600 x 1500B	52	12.3	50.0
MA600 x 1500A	52	17.5	71.3
MA600 x 2000B	52	16.0	65.0
MA600 x 2000A	52	22.8	92.9

**Morse 12" BUCKLING COLUMN FENDER**

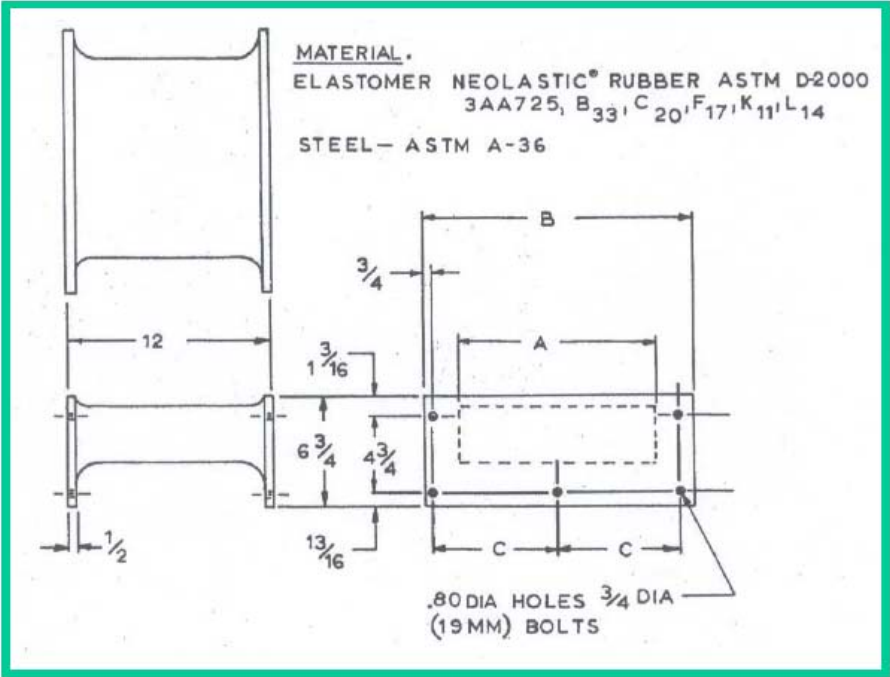

PART NO.	WT.	A	B	C
	25 LBS.	6	10	4 1/4
E46001	11,3 Kg.	(152.4)	(254.0)	(108.0)
	35 LBS.	9	13	5 3/4
E46002	15,9 Kg.	(228.6)	(330.2)	(146.1)
	45 LBS.	12	16	7 1/4
E46003	20,4 Kg.	(304.8)	(406.4)	(184.2)
	35 LBS.	9	13	5 3/4
E46004	15,9 Kg.	(228.6)	(330.2)	(146.1)
	50 LBS.	12	16	7 1/4
E46005	22,7 Kg.	(304.8)	(406.4)	(184.2)

INCH	Cm.
1/2	1.27
3/4	1.91
.80	2.03
13/16	2.06
1 13/16	3.02
4 3/4	12.07
6 3/4	17.15

NOTE: ALL DIMENSIONS IN PARENTHESES ARE IN MILLIMETERS





## Morse 33" BUCKLING COLUMN FENDER

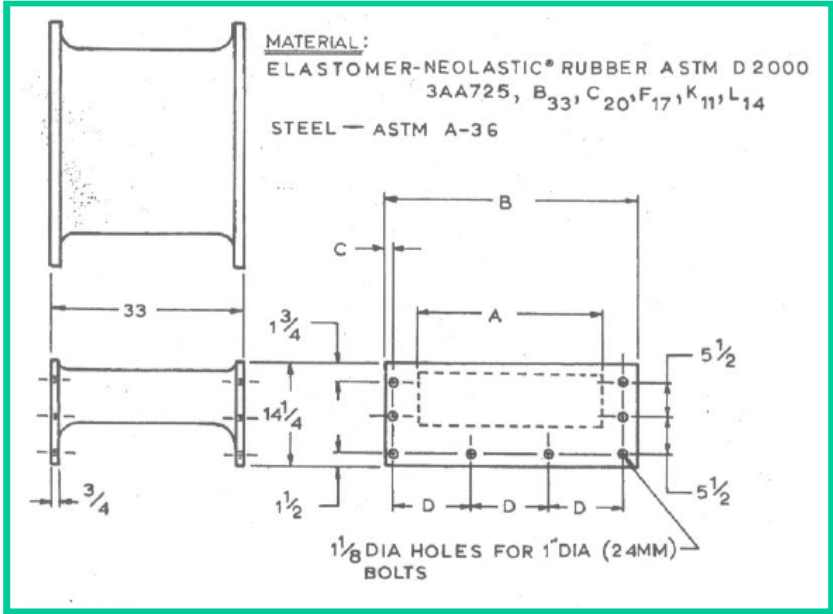

PART NO.	WT.	A	B	C	D
	235 LBS.	12	18 5/16	1 21/32	5
E46011	107 Kg.	(304.8)	(465.1)	(42.1)	(127)
	345 LBS.	18	24 5/16	1 21/32	7
E46012	157 Kg.	(457.2)	(617.5)	(42.1)	(177.8)
	400 LBS.	22	28 5/16	1 19/32	8 3/8
E46013	181 Kg.	(558.8)	(719.1)	(40.5)	(212.7)
	480 LBS.	26	32 5/16	1 5/8	9 2/3
E46014	218 Kg.	(660.4)	(820.7)	(41.3)	(246.1)
	550 LBS.	30	36 5/16	1 21/32	11
E46015	250 Kg.	(762.0)	(922.3)	(42.1)	(279.4)
	710 LBS.	34	40 5/16	1 19/32	12 3/8
E46016	322 kG.	(865)	(1023)	(40.5)	(314.3)
	790 LBS.	38	44 5/16	1 23/32	13 5/8
E46017	359 kG.	(965.2)	(1126)	(44.0)	(346.1)

INCH	Cm.
3/4	1.91
1 1/8	2.86
1 1/2	3.81
1 3/4	4.45
5 1/2	13.97
14 1/4	36.20
33	83.82

## Morse 48" BUCKLING COLUMN FENDER

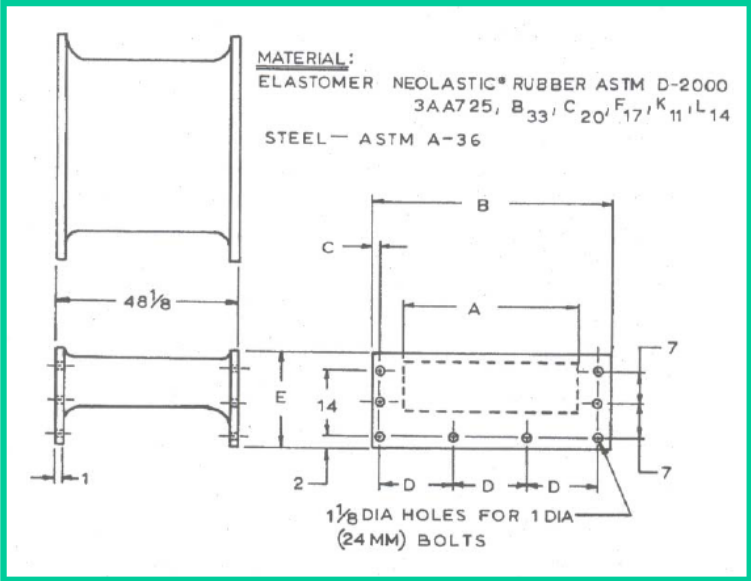

PART NO.	WT.	A	B	C	D	E
E46018	525 LBS.	14	20 5/16	1 29/32	5 1/2	19 1/2
	238 Kg.	(355.6)	(515.9)	(48.4)	(133.7)	(495.3)
E46019	635 LBS.	17 1/2	23 13/16	1 13/32	7	20 1/2
	288 Kg.	(444.5)	(604.8)	(35.7)	(177.8)	(520.7)
E46020	750 LBS.	21	27 5/16	1 21/32	8	20 1/2
	340 Kg.	(533.4)	(693.7)	(42.1)	(203.2)	(520.7)
E46021	870 LBS.	24 1/2	30 13/16	1 29/32	9	20 1/2
	394 Kg.	(622.3)	(782.6)	(48.4)	(228.6)	(520.7)
E46022	990 LBS.	28	34 5/16	1 13/32	10 1/2	20 1/2
	448 Kg.	(711.2)	(871.5)	(35.7)	(266.7)	(520.7)

INCH	Cm.
1	2.54
1 1/8	2.86
2	5.08
3 1/2	8.89
48 1/8	122.24

NOTE: ALL DIMENSIONS IN PARENTHESES ARE IN MILLIMETERS

### CONE FENDER DIMENSIONS

Fender	H	FD	SD	FBC	Anchors Dockside	SBC	Panel Bolts
MCE 300	300	500	295	440	4-M20	255	4-M20
MCE 350	350	570	330	510	4-M20	275	4-M20
MCE 400	400	650	390	585	4-M24	340	4-M24
MCE 500	500	800	490	730	4-M24	425	4-M24
MCE 550	550	880	540	790	4-M24	470	4-M24
MCE 600	600	960	590	875	4-M30	515	4-M30
MCE 700	700	1120	685	1020	4-M30	600	4-M30
MCE 800	800	1280	785	1165	6-M30	685	6-M30
MCE 900	900	1440	885	1313	6-M30	770	6-M30
MCE 1000	1000	1600	980	1460	6-M36	855	6-M36
MCE 1050	1050	1680	1030	1530	6-M36	900	6-M36
MCE 1100	1100	1760	1080	1605	8-M36	940	8-M36
MCE 1200	1200	1920	1175	1750	8-M42	1025	8-M42
MCE 1300	1300	2080	1275	1900	8-M48	1100	8-M48
MCE 1400	1400	2240	1370	2040	8-M48	1195	8-M48
MCE 1600	1600	2560	1570	2335	8-M48	1365	8-M48
MCE 1800	1800	2880	1765	2625	10-M56	1540	10-M56
MCE 2000	2000	3200	1955	2920	10-M56	1710	10-M56

Dimensions in millimeters

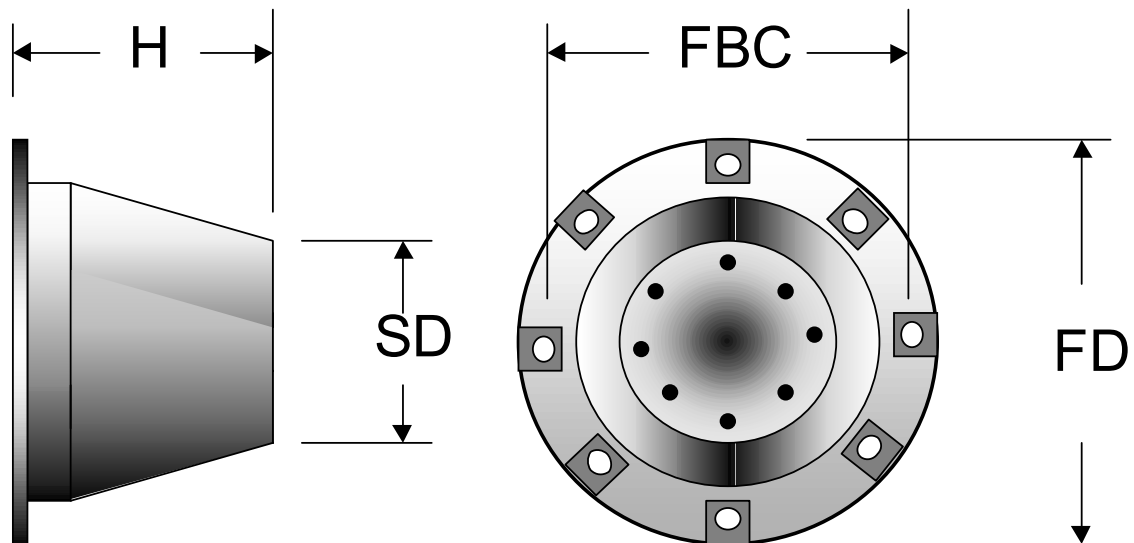

# Morse Super Cone Fenders - PERFORMANCE

		Fender Model										
		MCE300		MCE350		MCE400		MCE500		MCE550		
Rubber Compound	Energy	Reaction	Energy	Reaction	Energy	Reaction	Energy	Reaction	Energy	Reaction	Energy	Reaction
	Ft-Kips	Kips	kNM	kN	kNM	kN	kNM	kN	kNM	kN	kNM	kN
A1			kNM	104.00	23.10	140.00	34.60	184.00	67.70	290.00	90.00	349.00
A2			kNM	113.00	25.30	154.00	38.00	202.00	74.30	316.00	98.00	382.00
B1			kNM	82.00	18.50	110.00	27.70	146.00	54.00	228.00	72.00	275.00
B2			kNM	125.00	20.70	127.00	31.00	164.00	60.70	255.00	80.00	312.00
B3			kNM	137.00	22.80	139.00	34.00	180.00	66.10	280.00	89.00	346.00
C1			kNM	64.00	14.00	88.00	20.70	116.00	40.50	181.00	54.00	218.00
C2			kNM	74.00	16.20	99.00	24.10	130.00	47.20	204.00	63.10	247.00
C3			kNM	79.00	18.00	109.00	27.00	143.00	52.70	222.00	69.00	266.00
		Fender Model										
		MCE600		MCE700		MCE800		MCE900		MCE1000		
Rubber Compound	Energy	Reaction	Energy	Reaction	Energy	Reaction	Energy	Reaction	Energy	Reaction	Energy	Reaction
	kNM	kN	kNM	kN	kNM	kN	kNM	kN	kNM	kN	kNM	kN
A1			120.00	399.00	205.00	570.00	311.00	744.00	440.00	944.00	604.00	1163.00
A2			131.00	438.00	226.00	627.00	340.00	820.00	484.00	1040.00	666.00	1282.00
B1			90.00	314.00	165.00	450.00	245.00	592.00	345.00	744.00	475.00	920.00
B2			106.00	359.00	186.00	512.00	278.00	665.00	392.00	844.00	540.00	1042.00
B3			117.00	391.00	200.00	556.00	304.00	728.00	430.00	923.00	590.00	1140.00
C1			70.00	250.00	130.00	354.00	190.00	464.00	275.00	585.00	374.00	722.00
C2			80.00	282.00	149.00	406.00	218.00	527.00	310.00	664.00	425.00	822.00
C3			87.00	306.00	162.00	440.00	240.00	577.00	337.00	730.00	466.00	900.00
		Fender Model										
		MCE1050		MCE1100		MCE1200		MCE1300		MCE1400		
Rubber Compound	Energy	Reaction	Energy	Reaction	Energy	Reaction	Energy	Reaction	Energy	Reaction	Energy	Reaction
	kNM	KN	kNM	KN	kNM	KN	kNM	kN	kNM	kN	kNM	kN
A1			702.00	1287.00	806.00	1412.00	1045.00	1680.00	1330.00	1972.00	1660.00	2280.00
A2			771.00	1415.00	885.00	1550.00	1152.00	1850.00	1465.00	2170.00	1825.00	2510.00
B1			550.00	1015.00	635.00	1115.00	825.00	1325.00	2045.00	1556.00	1308.00	1806.00
B2			625.00	1151.00	720.00	1265.00	935.00	1502.00	1188.00	1765.00	1485.00	2040.00
B3			685.00	1259.00	789.00	1382.00	1023.00	1644.00	1302.00	1030.00	1624.00	2335.00
C1			435.00	799.00	501.00	876.00	650.00	1044.00	825.00	1225.00	1032.00	1420.00
C2			493.00	907.00	569.00	997.00	738.00	1186.00	935.00	1391.00	1165.00	1612.00
C3			539.00	995.00	622.00	1090.00	809.00	1298.00	1025.00	1530.00	1276.00	1765.00
		Fender Model										
		MCE1600		MCE1800		MCE2000						
Rubber Compound	Energy	Reaction	Energy	Reaction	Energy	Reaction						
	kNM	kN	kNM	kN	kNM	kN						
A1			2480.00	2982.00	3530.00	3777.00	4845.00	4665.00				
A2			2729.00	3279.00	3885.00	4155.00	5325.00	5125.00				
B1			1950.00	2356.00	2775.00	2980.00	3800.00	3680.00				
B2			2215.00	2670.00	3155.00	3379.00	4325.00	4202.00				
B3			2427.00	2920.00	3455.00	3696.00	4738.00	4570.00				
C1			1535.00	1858.00	2185.00	2350.00	3001.00	2902.00				
C2			1745.00	2101.00	2481.00	2666.00	3400.00	3292.00				
C3			1910.00	2307.00	2718.00	2920.00	3710.00	3600.00				

**Energy and Reaction are at rated deflection (72%)**

Values are for a single fender

Tolerance for Energy and Reaction +/-10%

The information in this document is a general description only, is not guaranteed and contains no warranties of any kind. Subject to change without notice.

## FENDER BARS

### Technical data

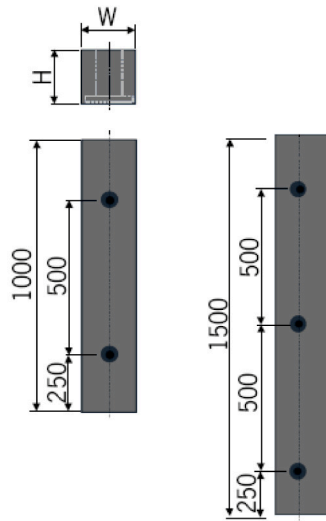

### General description

Morse fender bars are resistant to high impact loads and are suitable for a wide range of applications where energy requirements are low and relatively high reaction force/hull pressure is not a problem. These may include pile fenders, sheet-pile or concrete quays, ferry ramps and bumper guards on boat and barges. The heavy-duty mounting system is designed for simple installation and is embedded in the rubber in order to eliminate corrosion. Svedala fender bars can be bolted to steel channels which can then be welded into place. Customized fender bars with a layer of low-friction UHMW-PE bonded integrally or bolted to the face are also available.

### Dimension

W	H	Length
150	150	1000
150	150	1500
150	200	1000
150	200	1500
200	200	1000
200	200	1500
200	250	1000
200	250	1500
200	300	1000
200	300	1500

### Performance

Type (WxHxL)	E (Tm)	R (T)	Deflection (mm)
150x150x1000	1.7	65	75
150x150x1500	2.5	98	75
150x200x1000	1.7	45	100
150x200x1500	2.5	68	100
200x200x1000	2.7	84	100
200x200x1500	4.1	126	100
200x250x1000	2.7	67	125
200x250x1500	4.1	101	125
200x300x1000	2.7	54	150
200x300x1500	4.1	81	150

TLL6EN261

# EXTRUDED FENDERS

## Cylindrical Fenders

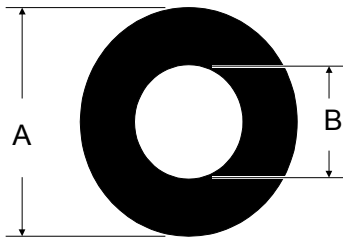

Part No.	Dims. - Inch		Wt./Ft. Lbs.	R/E Kip/Ft.Kip
	A	B		
F30000	3	1.5	3	14
F38000	5	2.5	7	10
F39000	6	2	14	11
F31000	8	4	18.5	10
F32000	10	5	30	6.2
F35000	12	6	42.5	5.3
F36000	15	7.5	68.5	3.5
F33000	18	9	97.5	2.9

## Cylindrical Wing Fenders

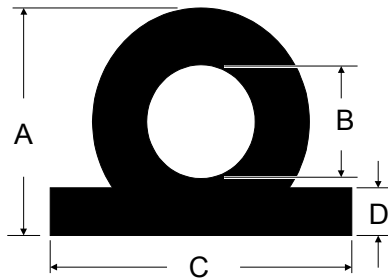

Part No.	Dimensions - Inch				Wt./Ft. Lbs.	R/E Kip/Ft.Kip
	A	B	C	D		
F70000	3	1	6	.75	4.3	25
F78000	4	2	7.5	1.0	10	19.5
F71000	6	3	9	1.5	15.5	13.5
F81000	8	4	12	2.0	30	11
F84000	10	5	15	2.5	44	9
F73000	12	6	18	3.0	58.5	6.3

## Square Fenders

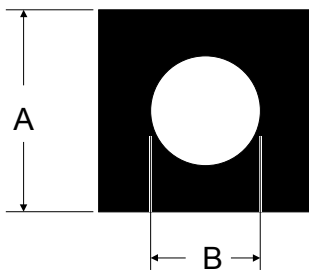

Part No.	Dims. - Inch		Wt./Ft. Lbs.	R/E Kip/Ft.Kip
	A	B		
F60000	4.5	1.5	4.5	2.0
F62000	6	2	14	16
F56000	7	2.5	22.5	12.5
F50000	8	3	29.5	10
F57000	10	4	45	8.5
F51000	12	5	63	7
F52000	14	6	81	3.7
G62000	16	7	112	2.5

**Morse Rubber LLC**

# EXTRUDED FENDERS

## D- O Bore Fenders

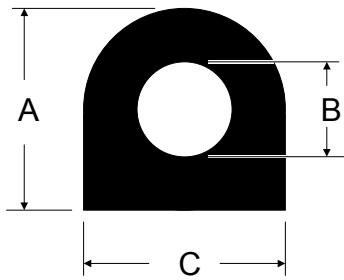

Part No.	Dims. - Inch			Wt./Ft. Lbs.	R/E Kip/Ft.Kip
	A	B	C		
F92000	6	2.5	5	11.5	15.2
F95000	8	3	8	22	10
G05000	10	4	10	38	8.6
F93000	12	5	12	54	7.7
F98000	14	6	14	73	4.2

## D- D bore Fenders

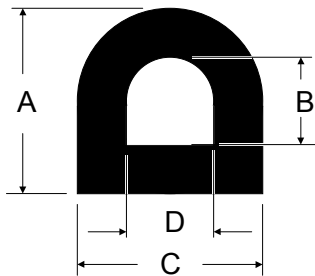

Part No.	Dims. - Inch			Wt./Ft. Lbs.	R/E Kip/Ft.Kip
	A	BxD	C		
G54000	6	3	5	11.5	15.2
F90000	8	4	8	22	10
G07000	10	5	10	38	8.6
F97000	12	6	12	54	7.7
G06000	14	7	14	73	4.2

## Slope D- Fenders

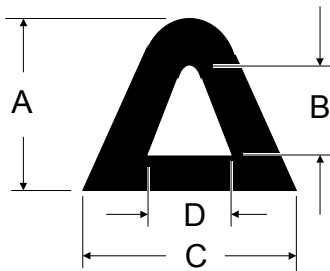

Part No.	Dims. - Inch				Wt./Ft. Lbs.	R/E Kip/Ft.Kip
	A	B	C	D		
F94000	3.75	2.25	4.5	2	4.5	16.7
F91000	6	3	6.75	2.37	12.3	13.3

**Morse Rubber LLC**

# TYPE-CB FENDERS



**Morse Rubber**



# Type CB Fender

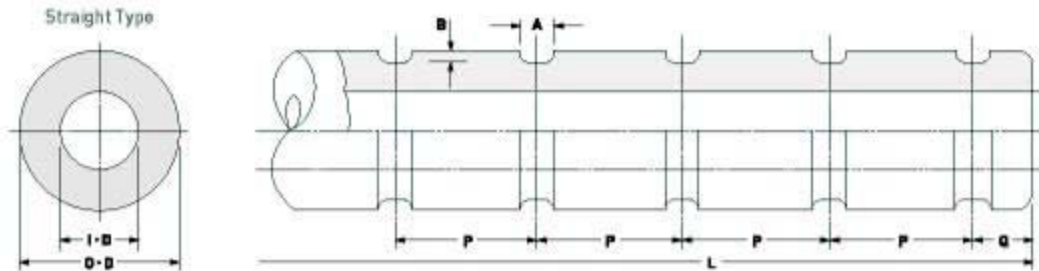

Fender Dimension (Use:For Side)

Size	100 $\phi$ $\times$ 50 $\phi$	150 $\phi$ $\times$ 75 $\phi$	200 $\phi$ $\times$ 100 $\phi$	250 $\phi$ $\times$ 125 $\phi$	300 $\phi$ $\times$ 150 $\phi$	350 $\phi$ $\times$ 175 $\phi$	400 $\phi$ $\times$ 200 $\phi$	500 $\phi$ $\times$ 250 $\phi$	600 $\phi$ $\times$ 300 $\phi$	700 $\phi$ $\times$ 350 $\phi$
O-D	100	150	200	250	300	350	400	500	600	700
I-D	50	75	100	125	150	175	200	250	300	350
A	30	30	50	50	50	70	70	70	85	85
B	10	10	15	15	15	20	20	30	30	40
P	600-900	600-900	600-900	600-900	600-900	600-900	600-900	600-900	600-900	600-900
Q	100	100	150	150	200	200	200	250	250	300

\* Maximum length available is 20m.

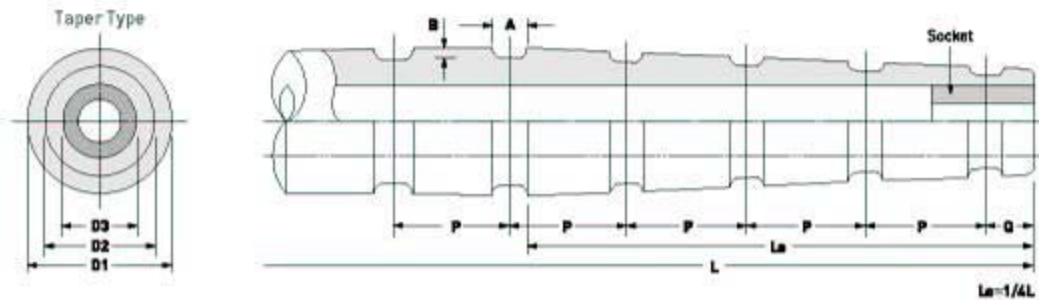

Fender Dimension (Use:For Bow and Stern)

Size	200 $\phi$ $\times$ 100 $\phi$	250 $\phi$ $\times$ 125 $\phi$	300 $\phi$ $\times$ 150 $\phi$	350 $\phi$ $\times$ 175 $\phi$	400 $\phi$ $\times$ 200 $\phi$	500 $\phi$ $\times$ 250 $\phi$	600 $\phi$ $\times$ 300 $\phi$	700 $\phi$ $\times$ 350 $\phi$	800 $\phi$ $\times$ 400 $\phi$
D1	200	250	300	350	400	500	600	700	800
D2	150	190	225	260	300	375	450	525	600
D3	100	125	150	175	200	250	300	350	400
A	50	50	50	70	70	70	85	85	85
B	15	15	15	20	20	30	30	40	40
P	600-900	600-900	600-900	600-900	600-900	600-900	600-900	600-900	600-900
Q	150	150	200	200	200	250	250	300	300
Socket	O-D	-	-	-	202	252	303	354	404
	I-D	-	-	-	100	100	150	150	150
	Length	-	-	-	300	350	400	400	400

\* Maximum length available is 20m.

## Morse Rubber LLC

# TYPE-W FENDERS



**Morse Rubber**

# TYPE-W BLOCK FENDERS

Morse Type-W Block Fenders are made of tough wear resistant synthetic rubber to withstand the most severe service. This modular fender system provides wide flexibility in design, allowing custom fit to hull curves and varying vertical coverage requirements.



**BLOCKFENDER TYPE W**

FENDER TYPE	DIMENSIONS IN MM							
	A	B	C	D	E	F	R MIN	Ø BAR
W-32-20	320	200	180	67	40	17	600	20
W-40-25	400	250	220	75	50	20	800	25
W-48-30	480	300	265	80	60	25	900	35

Additional sizes available per customer request.

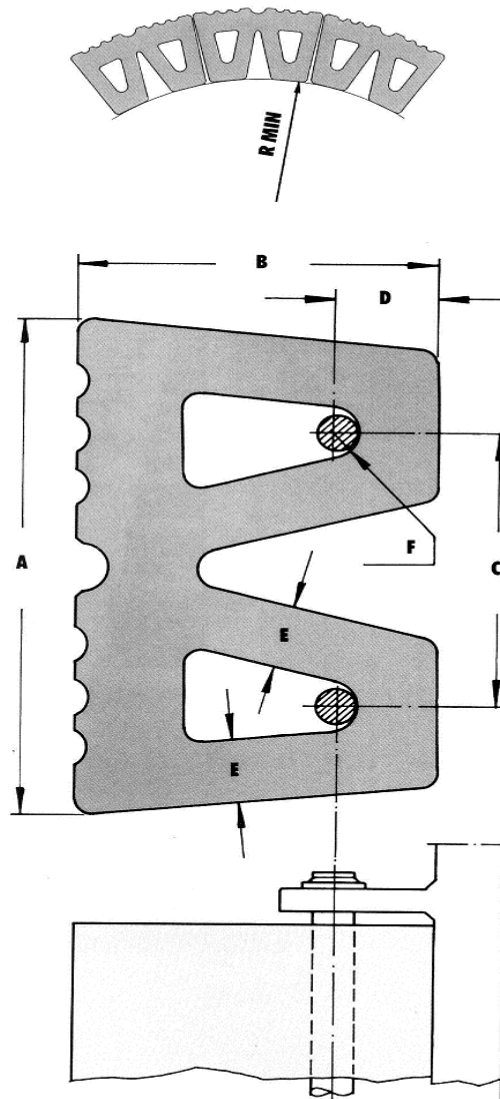

# Morse

## KEYHOLE BLOCK FENDERS



**Morse Rubber**

# KEYHOLE BLOCK FENDERS

Trellex Keyhole Block Fenders are made of tough wear resistant synthetic rubber to withstand the most severe service.

The modular design provides wide flexibility in design, allowing custom fit to hull curves and varying vertical coverage requirements.

Type	Dimensions (mm)			
	A	B	C	D
8E	200	40	140	20
8A	250	50	150	20
8B	304	60	184	25
8C	350	70	210	25

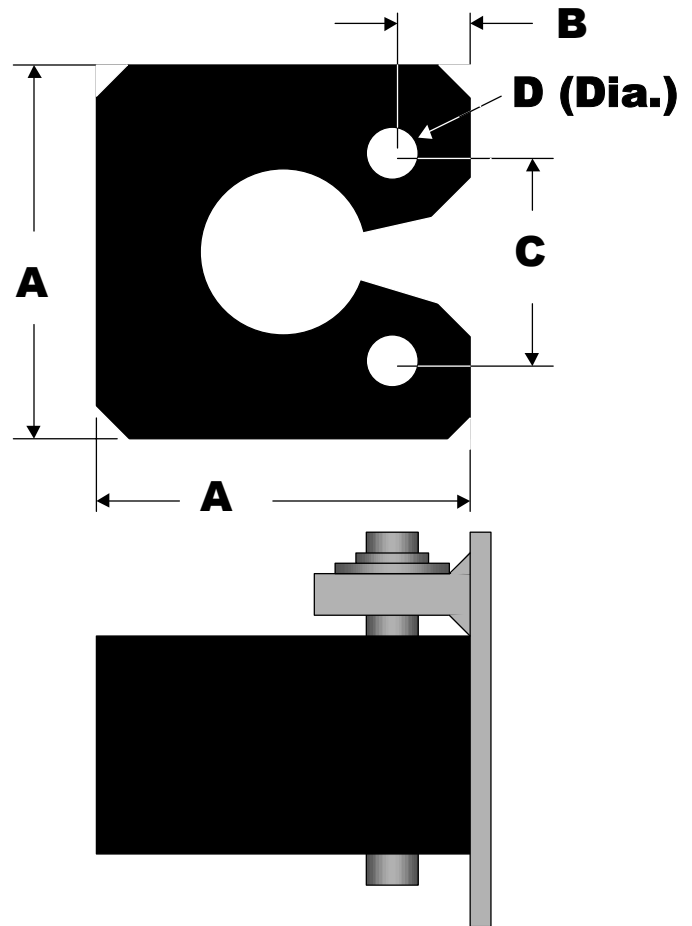

**Morse Rubber LLC**

## MCL CELL FENDER

Fender Performance At Design Deflection

	F0		F1		F2		F3		F4		Size
	52.5%		52.5%		52.5%		52.5%		52.5%		
	R/F (kN)	E/A (kNm)	R/F (kN)	E/A (kNm)	R/F (kN)	E/A (kNm)	R/F (kN)	E/A (kNm)	R/F (kN)	E/A (kNm)	
500H	184	40.5	163	35.9	141	31.1	109	23.9	87.1	19.1	500H
600H	265	69.9	235	62.1	204	53.7	157	41.4	126	33.0	600H
800H	471	166	418	147	362	128	279	98.1	223	78.5	800H
1000H	736	324	653	287	566	249	435	191	348	153	1000H
1150H	973	492	863	436	748	379	576	291	461	233	1150H
1250H	1147	633	1020	561	884	486	680	374	544	299	1250H
1450H	1550	991	1373	876	1187	759	915	584	732	467	1450H
1600H	1883	1324	1667	1177	1451	1020	1118	785	891	628	1600H
1700H	2128	1589	1883	1412	1638	1226	1255	940	1010	751	1700H
2000H	2942	2589	2609	2295	2265	1991	1746	1530	1393	1226	2000H
2250H	3727	3687	3305	3275	2864	2834	2207	2177	1765	1746	2250H
2500H	4597	5056	4082	4489	3536	3892	2721	2988	2176	2391	2500H
3000H	6620	8737	5878	7757	5092	6726	3919	5162	3133	4131	3000H

\* PERFORMANCE TOLERANCE ±10%

Small Reduction Force for Angular Compression Performance Adjustment Factor from 52.5% deflecting Value

Angle (deg)	0	3	4	5	6	7	8	9	10	15	20
Compress until Design Fender Reaction Force Value											
E/A	1.000	0.977	0.966	0.950	0.936	0.922	0.910	0.898	0.883	0.801	0.652
R/F	1.000	1.000	1.000	1.000	1.000	1.000	1.000	1.000	1.000	1.000	1.000
Compress until Maximum Fender Reaction Force Value											
E/A	1.059	1.036	1.024	1.009	0.997	0.982	0.968	0.955	0.940	0.861	0.722
R/F	1.063	1.063	1.063	1.063	1.063	1.063	1.063	1.063	1.063	1.063	1.063

Performance of Intermediate Deflection

Deflection (%)	R/F	E/A
0	0%	0%
5	39%	2%
10	70%	8%
15	88%	17%
20	96%	28%
25	100%	39%
30	99%	50%
35	97%	62%
40	96%	72%
45	95%	83%
50	97%	94%
52.5	100%	100%
55	107%	106%

Temperature Factor

Temperature (°C)	TF
-20	1.375
-10	1.182
0	1.083
10	1.034
23	1
30	0.976
40	0.945
50	0.918
60	0.917

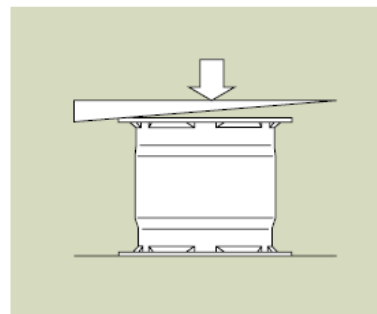

# Morse Rubber

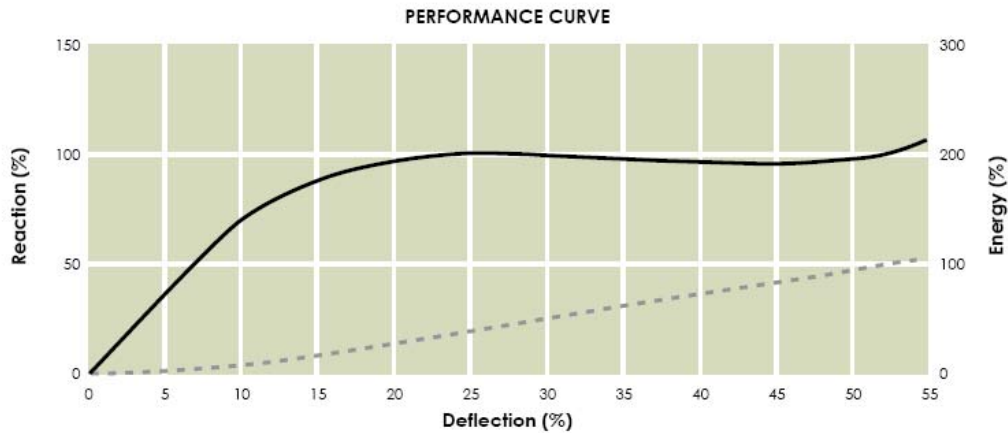

## Dimension of CSS Fender

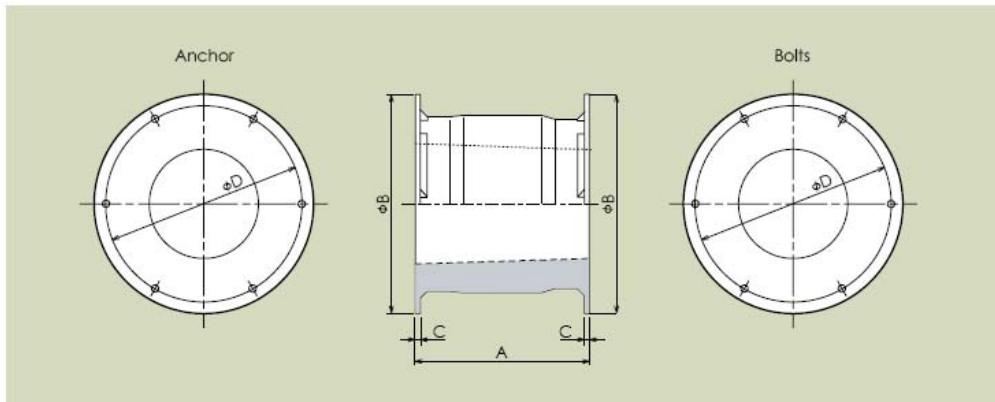

	A	$\phi B$	C	$\phi D$	Anchor	New Jetty	Existing	Weight	
						FL Bolts	CR Bolt		
	(mm)	(mm)	(mm)	(mm)		kg	kg	kg	
500H	500	650	16-20	550	4XM24	1.56	1.22	110	500H
600H	600	780	20-25	660	4XM27	1.84	1.7	197	600H
800H	800	1050	27-33	900	6XM30	2.7	2.27	432	800H
1000H	1000	1230	32-40	1100	6XM36	4.21	3.72	760	1000H
1150H	1150	1440	37-45	1300	6XM42	7.38	6.23	1205	1150H
1250H	1250	1600	40-49	1450	6XM42	7.38	6.23	1550	1250H
1450H	1450	1820	42-45	1650	6XM48	10.5	9.22	2350	1450H
1600H	1600	1960	45-46	1800	8XM48	10.5	9.22	2940	1600H
1700H	1700	2100	50-60	1900	8XM56	16.7	14.8	3730	1700H
2000H	2000	2200	50-62	2000	8XM64	20.4	21.3	5260	2000H
2250H	2250	2550	59-63	2300	10XM64	20.4	21.3	7450	2250H
2500H	2500	2950	69-84	2700	10XM64	20.4	21.3	10750	2500H
3000H	3000	3350	82-98	3150	12XM76	34.0	N/A	18600	3000H

## FENDER ELEMENT MRV300

### Technical data

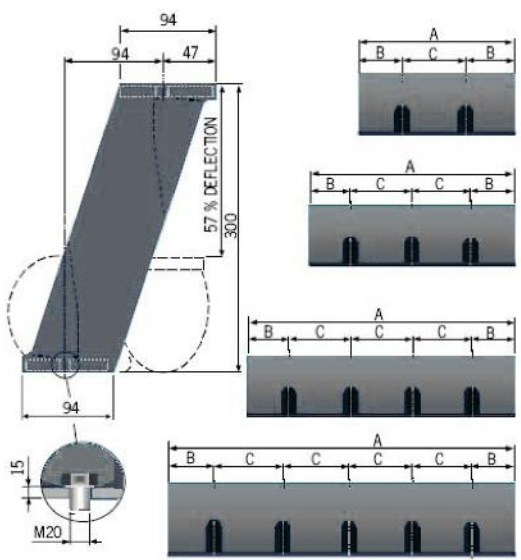

### General description

The fender element is an efficient buckling type fender. It has a sophisticated trapezoidal geometry which under compression, buckles into a distinctive "S" shape for optimum performance.

The fixings are placed on the neutral axis to keep static and dynamic bolt loads to a minimum. The fender elements are compression moulded under high pressure to secure a solid, homogeneous rubber fender without pores, air enclosures or cracks. The metal mounting flanges are chemically bonded to and totally encapsulated within the rubber, to eliminate any risk of corrosion.

### Dimension

Element	A	B	C
MV300 x 600	600	150	300
MV300 x 900	900	150	2 x 300
MV300 x 1200	1200	150	3 x 300
MV300 x 1500	1500	150	5 x 300

### Performance

Element	compound A (velocity 0.30m/s)		compound B (velocity 0.30m/s)	
	E(Tm.)	R(T.)	E(Tm.)	R(T.)
MV300 x 600	1.3	9.8	0.9	6.8
MV300 x 900	2.0	14.7	1.4	10.3
MV300 x 1200	2.6	19.6	1.8	13.7
MV300 x 1500	3.3	24.5	2.3	17.2

TL16EN230



## FENDER ELEMENT MRV400

### Technical data

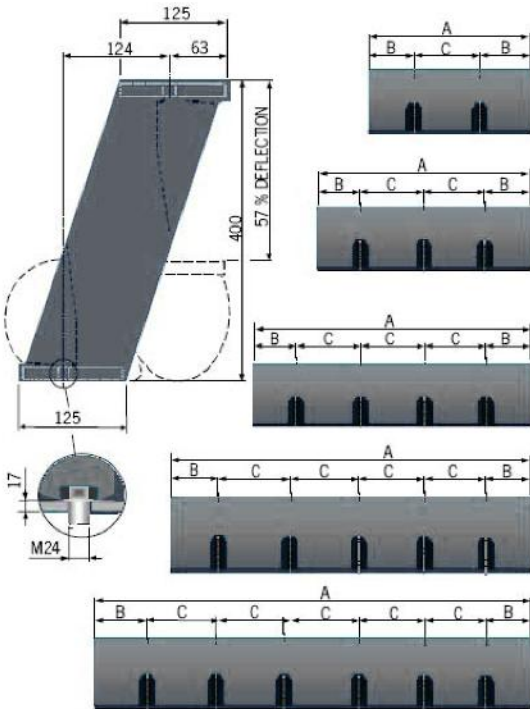

### Dimension

Element	A	B	C
MV400 x 750	750	125	500
MV400 x 1000	1000	250	500
MV400 x 1500	1500	250	2 x 500
MV400 x 2000	2000	250	3 x 500
MV400 x 2500	2500	250	4 x 500
MV400 x 3000	3000	250	5 x 500

### General description

The fender element is an efficient buckling type fender. It has a sophisticated trapezoidal geometry which under compression, buckles into a distinctive "S" shape for optimum performance.

The fixings are placed on the neutral axis to keep static and dynamic bolt loads to a minimum. The fender elements are compression moulded under high pressure to secure a solid, homogeneous rubber fender without pores, air enclosures or cracks. The metal mounting flanges are chemically bonded to and totally encapsulated within the rubber, to eliminate any risk of corrosion.

### Performance

Element	compound A (velocity 0.30m/s)		compound B (velocity 0.30m/s)	
	E(Tm.)	R(T.)	E(Tm.)	R(T.)
MV400 x 750	3.0	16.4	2.1	11.5
MV400 x 1000	4.0	21.8	2.8	15.3
MV400 x 1500	6.0	32.7	4.2	22.9
MV400 x 2000	8.0	43.6	5.6	30.6
MV400 x 2500	10.0	54.5	7.0	38.2
MV400 x 3000	12.0	65.4	8.4	45.8

## FENDER ELEMENT MRV500

### Technical data

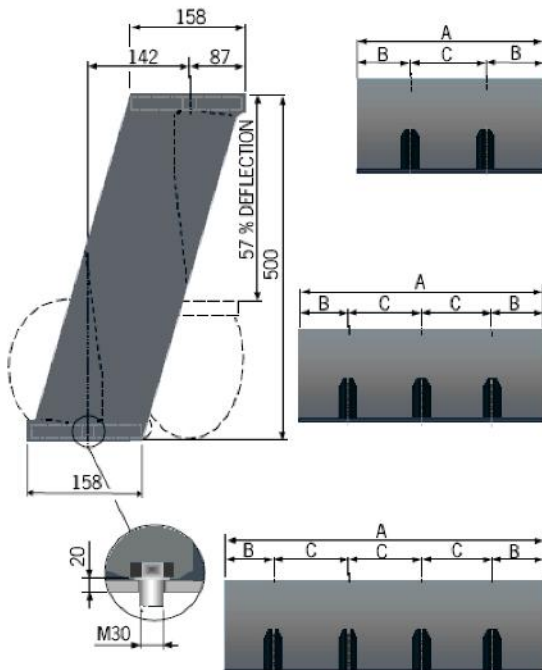

### General description

The fender element is an efficient buckling type fender. It has a sophisticated trapezoidal geometry which under compression, buckles into a distinctive "S" shape for optimum performance.

The fixings are placed on the neutral axis to keep static and dynamic bolt loads to a minimum. The fender elements are compression moulded under high pressure to secure a solid, homogeneous rubber fender without pores, air enclosures or cracks. The metal mounting flanges are chemically bonded to and totally encapsulated within the rubber, to eliminate any risk of corrosion.

### Dimension

Element	A	B	C
MV500 x 1000	1000	250	500
MV500 x 1500	1500	250	2 x 500
MV500 x 2000	2000	250	3 x 500

### Performance

Element	compound A (velocity 0.30m/s)		compound B (velocity 0.30m/s)	
	E(Tm.)	R(T.)	E(Tm.)	R(T.)
MV500 x 1000	6.2	27.2	4.3	19.0
MV500 x 1500	9.3	40.8	6.5	28.6
MV500 x 2000	12.4	54.4	8.7	38.2

## FENDER ELEMENT MRV550

### Technical data

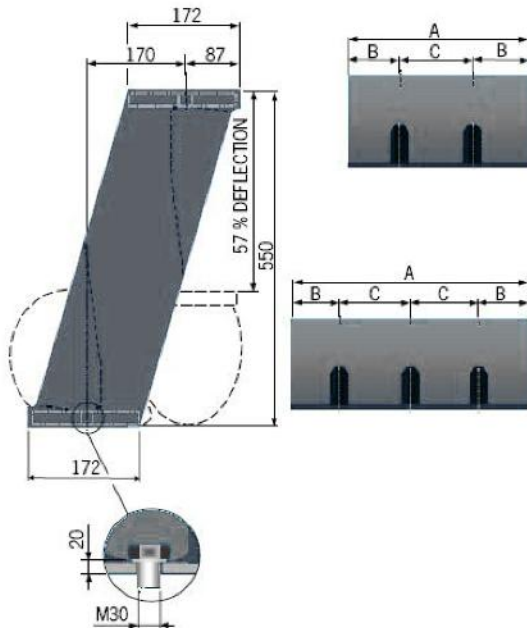

### General description

The fender element is an efficient buckling type fender. It has a sophisticated trapezoidal geometry which under compression, buckles into a distinctive “S” shape for optimum performance.

The fixings are placed on the neutral axis to keep static and dynamic bolt loads to a minimum. The fender elements are compression moulded under high pressure to secure a solid, homogeneous rubber fender without pores, air enclosures or cracks. The metal mounting flanges are chemically bonded to and totally encapsulated within the rubber, to eliminate any risk of corrosion.

### Dimension

Element	A	B	C
MV550 x 750	750	125	500
MV550 x 1000	1000	250	500
MV550 x 1500	1500	250	2 x 500

### Performance

Element	compound A (velocity 0.30m/s)		compound B (velocity 0.30m/s)	
	E(Tm.)	R(T.)	E(Tm.)	R(T.)
MV550 x 750	5.7	22.5	4.0	15.7
MV550 x 1000	7.6	30.0	5.3	21.0
MV550 x 1500	11.4	45.0	8.0	31.5

## FENDER ELEMENT MRV600

### Technical data

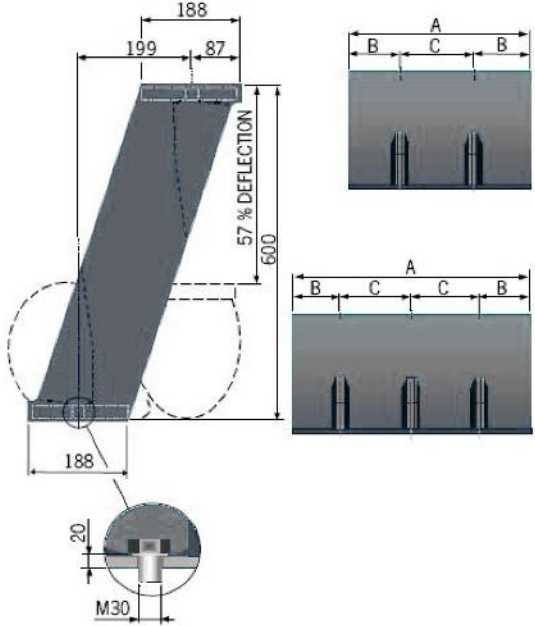

### General description

The fender element is an efficient buckling type fender. It has a sophisticated trapezoidal geometry which under compression, buckles into a distinctive "S" shape for optimum performance.

The fixings are placed on the neutral axis to keep static and dynamic bolt loads to a minimum. The fender elements are compression moulded under high pressure to secure a solid, homogeneous rubber fender without pores, air enclosures or cracks. The metal mounting flanges are chemically bonded to and totally encapsulated within the rubber, to eliminate any risk of corrosion.

### Dimension

Element	A	B	C
MV600 x 1000	1000	250	500
MV600 x 1500	1500	250	2 x 500

### Performance

Element	compound A (velocity 0.30m/s)		compound B (velocity 0.30m/s)	
	E(Tm.)	R(T.)	E(Tm.)	R(T.)
MV600 x 1000	9.0	32.6	6.3	22.8
MV600 x 1500	13.5	48.9	9.5	34.2

## FENDER ELEMENT MRV750

### Technical data

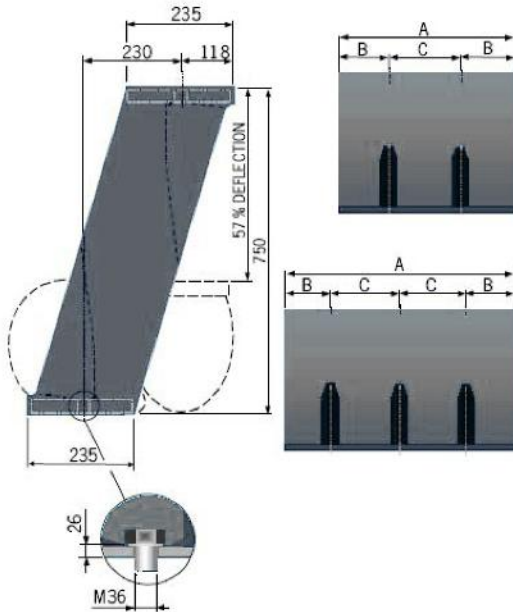

### General description

The fender element is an efficient buckling type fender. It has a sophisticated trapezoidal geometry which under compression, buckles into a distinctive “S” shape for optimum performance.

The fixings are placed on the neutral axis to keep static and dynamic bolt loads to a minimum. The fender elements are compression moulded under high pressure to secure a solid, homogeneous rubber fender without pores, air enclosures or cracks. The metal mounting flanges are chemically bonded to and totally encapsulated within the rubber, to eliminate any risk of corrosion.

### Dimension

Element	A	B	C
MV750 x 750	750	125	500
MV750 x 1000	1500	250	500
MV750 x 1500	1500	250	2 x 500

### Performance

Element	compound A (velocity 0.30m/s)		compound B (velocity 0.30m/s)	
	E(Tm.)	R(T.)	E(Tm.)	R(T.)
MV750 x 750	10.5	30.7	7.3	21.5
MV750 x 1000	14.0	41.0	9.8	28.7
MV750 x 1500	21.0	61.5	14.7	43.1

## FENDER ELEMENT MRV800

### Technical data

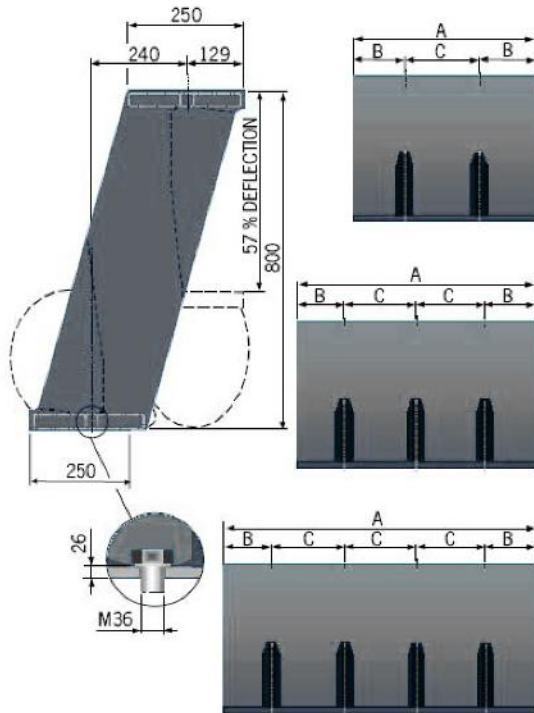

### General description

The fender element is an efficient buckling type fender. It has a sophisticated trapezoidal geometry which under compression, buckles into a distinctive "S" shape for optimum performance.

The fixings are placed on the neutral axis to keep static and dynamic bolt loads to a minimum. The fender elements are compression moulded under high pressure to secure a solid, homogeneous rubber fender without pores, air enclosures or cracks. The metal mounting flanges are chemically bonded to and totally encapsulated within the rubber, to eliminate any risk of corrosion.

### Dimension

Element	A	B	C
MV800 x 1000	1000	250	500
MV800 x 1500	1500	250	2 x 500
MV800 x 2000	2000	250	3 x 500

### Performance

Element	compound A (velocity 0.30m/s)		compound B (velocity 0.30m/s)	
	E(Tm.)	R(T.)	E(Tm.)	R(T.)
MV800 x 1000	16.0	43.6	11.2	30.5
MV800 x 1500	24.0	65.4	16.8	45.8
MV800 x 2000	32.0	87.2	22.4	61.0

# FENDER ELEMENT MRV1000

## Technical data

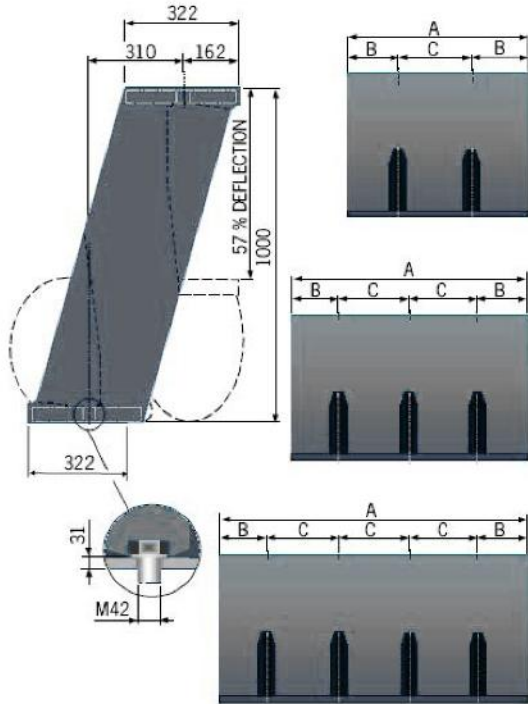

### General description

The fender element is an efficient buckling type fender. It has a sophisticated trapezoidal geometry which under compression, buckles into a distinctive "S" shape for optimum performance.

The fixings are placed on the neutral axis to keep static and dynamic bolt loads to a minimum. The fender elements are compression moulded under high pressure to secure a solid, homogeneous rubber fender without pores, air enclosures or cracks. The metal mounting flanges are chemically bonded to and totally encapsulated within the rubber, to eliminate any risk of corrosion.

### Dimension

Element	A	B	C
MV1000 x 800	800	150	500
MV1000 x 850	850	175	500
MV1000 x 900	900	200	500
MV1000 x 950	950	225	500
MV1000 x 1000	1000	250	500
MV1000 x 1050	1050	275	500
MV1000 x 1100	1100	300	500
MV1000 x 1150	1150	325	500
MV1000 x 1200	1200	350	500
MV1000 x 1500	1500	250	2 x 500
MV1000 x 2000	2000	250	3 x 500

### Performance

Element	compound A (velocity 0.30m/s)		compound B (velocity 0.30m/s)	
	E(Tm.)	R(T.)	E(Tm.)	R(T.)
MV1000 x 800	20.0	43.5	14.0	30.5
MV1000 x 850	21.2	46.2	14.9	32.4
MV1000 x 900	22.5	49.0	15.8	34.3
MV1000 x 950	23.8	51.7	16.6	36.2
MV1000 x 1000	25.0	54.4	17.5	38.1
MV1000 x 1050	26.3	57.1	18.4	40.0
MV1000 x 1100	27.5	59.8	19.3	41.9
MV1000 x 1150	28.8	62.6	20.1	43.8
MV1000 x 1200	30.0	65.3	21.0	45.7
MV1000 x 1500	37.5	81.6	26.3	57.1
MV1000 x 2000	50.0	108.8	35.0	76.2

## FENDER ELEMENT MRV1250

### Technical data

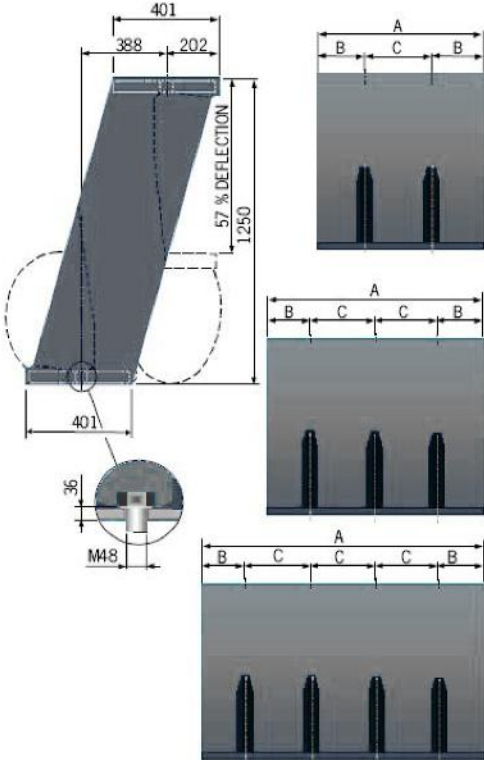

### Dimension

Element	A	B	C
MV1250 x 800	800	150	500
MV1250 x 850	850	175	500
MV1250 x 900	900	200	500
MV1250 x 950	950	225	500
MV1250 x 1000	1000	250	500
MV1250 x 1050	1050	275	500
MV1250 x 1100	1100	300	500
MV1250 x 1150	1150	325	500
MV1250 x 1200	1200	350	500
MV1250 x 1500	1500	250	2 x 500
MV1250 x 2000	2000	250	3 x 500

### General description

The fender element is an efficient buckling type fender. It has a sophisticated trapezoidal geometry which under compression, buckles into a distinctive "S" shape for optimum performance.

The fixings are placed on the neutral axis to keep static and dynamic bolt loads to a minimum. The fender elements are compression moulded under high pressure to secure a solid, homogeneous rubber fender without pores, air enclosures or cracks. The metal mounting flanges are chemically bonded to and totally encapsulated within the rubber, to eliminate any risk of corrosion.

### Performance

Element	compound A (velocity 0.30m/s)		compound B (velocity 0.30m/s)	
	E(Tm.)	R(T.)	E(Tm.)	R(T.)
MV1250 x 800	31.2	54.4	21.8	38.1
MV1250 x 850	33.2	57.8	23.2	40.5
MV1250 x 900	35.1	61.2	24.6	42.8
MV1250 x 950	37.1	64.6	25.9	45.2
MV1250 x 1000	39.0	68.0	27.3	47.6
MV1250 x 1050	41.0	71.4	28.7	50.0
MV1250 x 1100	42.9	74.8	30.0	52.4
MV1250 x 1150	44.9	78.2	31.4	54.7
MV1250 x 1200	46.8	81.6	32.8	57.1
MV1250 x 1500	58.5	102.0	41.0	71.4
MV1250 x 2000	78.0	136.0	54.6	95.2



## FENDER ELEMENT MRV1450

### Technical data

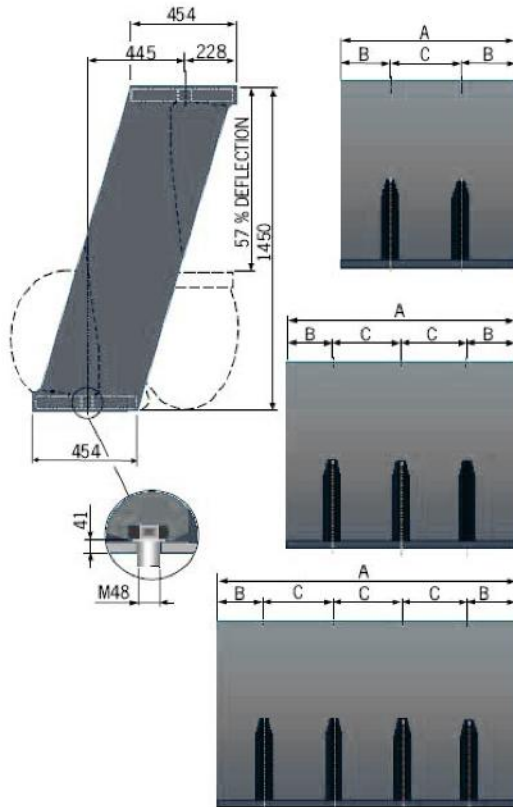

### Dimension

Element	A	B	C
MV1450 x 1000	1000	250	500
MV1450 x 1500	1500	250	2 x 500
MV1450 x 2000	2000	250	3 x 500

### General description

The fender element is an efficient buckling type fender. It has a sophisticated trapezoidal geometry which under compression, buckles into a distinctive "S" shape for optimum performance.

The fixings are placed on the neutral axis to keep static and dynamic bolt loads to a minimum. The fender elements are compression moulded under high pressure to secure a solid, homogeneous rubber fender without pores, air enclosures or cracks. The metal mounting flanges are chemically bonded to and totally encapsulated within the rubber, to eliminate any risk of corrosion.

### Performance

Element	compound A (velocity 0.30m/s)		compound B (velocity 0.30m/s)	
	E(Tm.)	R(T.)	E(Tm.)	R(T.)
MV1450 x 1000	52.6	79.0	36.8	55.3
MV1450 x 1500	78.9	118.5	55.2	83.0
MV1450 x 2000	105.2	158.0	73.6	110.6

## FENDER ELEMENT MRV1600

### Technical data

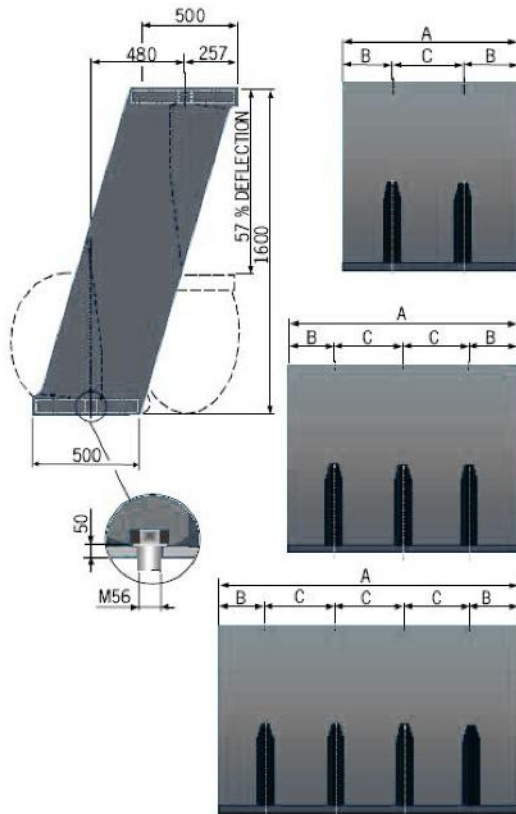

### Dimension

Element	A	B	C
MV1600 x 1000	1000	250	500
MV1600 x 1500	1500	250	2 x 500
MV1600 x 2000	2000	250	3 x 500

### General description

The fender element is an efficient buckling type fender. It has a sophisticated trapezoidal geometry which under compression, buckles into a distinctive "S" shape for optimum performance.

The fixings are placed on the neutral axis to keep static and dynamic bolt loads to a minimum. The fender elements are compression moulded under high pressure to secure a solid, homogeneous rubber fender without pores, air enclosures or cracks. The metal mounting flanges are chemically bonded to and totally encapsulated within the rubber, to eliminate any risk of corrosion.

### Performance

Element	compound A (velocity 0.30m/s)		compound B (velocity 0.30m/s)	
	E(Tm.)	R(T.)	E(Tm.)	R(T.)
MV1600 x 1000	64.0	87.2	44.8	61.0
MV1600 x 1500	96.0	130.8	67.2	91.6
MV1600 x 2000	128.0	174.4	89.6	122.1

# MORSE SHEAR FENDER

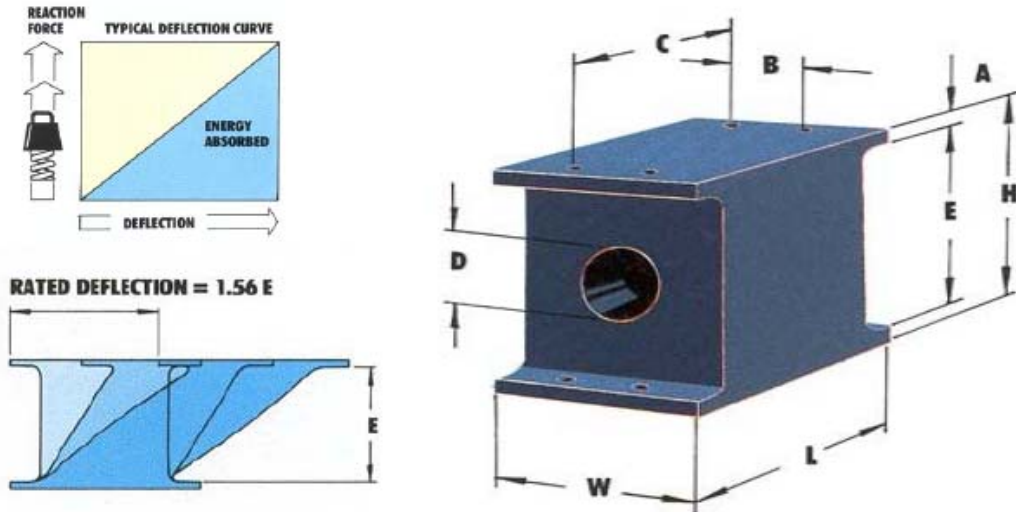

Dimensions (Inches)							
Part No.	W	H	L	A	B	C	D
E46496	10	11 5/8	15 3/4	5/8	4	14 1/8	4
E46498	12	13 7/8	18 7/8	11/16	5	16 15/16	5
E46500	14	16	22	3/4	5 1/2	19 3/4	6
E46502	16	18 9/16	25 1/8	15/16	7	22 5/8	7
E46504	18	20 15/16	28 1/4	1 1/16	8	25 3/8	8
E46506	20	22 15/16	31 3/8	1 1/16	9	28 1/4	9
E46508	22	25 3/8	34 1/2	1 1/4	10	31	10
E46510	24	27 3/4	37 3/4	1 3/8	11	33 7/8	11

Part No.	Shear				Compression			
	Energy Absorbed		Reaction		Energy Absorbed		Reaction	
	Ton-M	Ft.-Kips	Tonnes	Kips	Ton-M	Ft.-Kips	Tonnes	Kips
E46496	0.87	6.3	4.3	9.5	0.21	1.5	4.5	10
E46498	1.47	10.6	5.9	13	0.35	2.5	6.3	14
E46500	2.27	16.4	7.8	17.1	0.57	4.1	9.1	20
E46502	3.3	23.9	10.1	22.3	0.86	6.2	11.8	26
E46504	4.67	33.7	12.3	27.4	1.19	8.6	14.5	32
E46506	6.08	44	14.6	32.1	1.59	11.5	17.7	39
E46508	7.91	57.2	17.2	37.9	2.12	15.3	21.3	47
E46510	10.06	72.8	20.3	44.8	2.74	19.8	25.4	56