

REVISIONS			
REV	DESCRIPTION	DATE	APPROVED
NC	INITIAL RELEASE	08-05-02	ECO 2878
A	REV TS-2X4 WIRING & LABELING	10-14-02	

### IMPORTANT INSTALLATION NOTES

- 40 and 50 amp breakers are rated to a maximum of 120 VAC line-to-neutral or 240 VAC line-to-line. They are not rated for 240 VAC line-to neutral systems.
- The maximum current capacity of the installed bus bar is 50 amps. Also, a 50 amp double-pole master breaker must be installed if total loads at any given time may exceed 30 amps.
- See the reverse of this sheet for important information regarding panel wiring to conform to USCG regulations and ABYC standards.

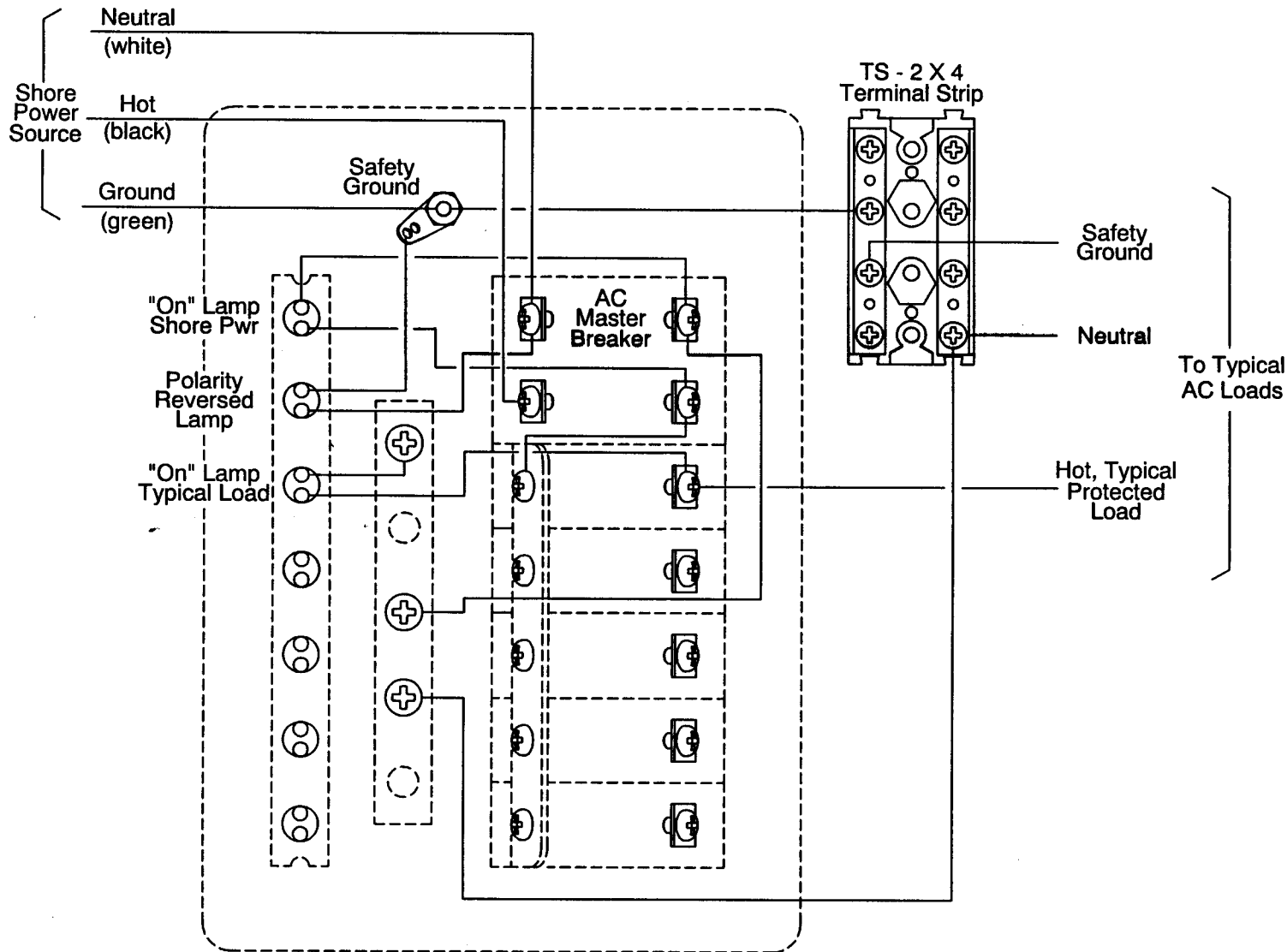

<b>NEWMAR</b>			
WIRING DIAGRAM, DISTRIBUTION PANEL, MODEL AC-1			
APPROVALS	DATE	SCALE	SIZE
DRAWN R. ARONSON	08-05-2002	NONE	A
CHECKED			
ENGR.			
		DRAWING NO.	REV.
		14358-1	A
SHEET 1 OF 1			