

Automatic Power Selector

Model: APS-70

INSTALLATION INSTRUCTIONS

General Description

The APS (Automatic Power Selector) provides a simple, solid-state solution to the need for routing redundant DC power sources for vital electronic equipment while maintaining isolation of the DC power sources.

Document Note: The APS may be used to facilitate redundant power from any DC power source, such as AC-DC power supplies or DC-DC converters, as well as batteries. For simplicity of explanation, these instructions refer to batteries as the power source, though any DC source may be used, as long as both sources are of the same nominal voltage.

Two independent batteries are wired to separate terminals on the APS and internal diodes (also known as "or-ing" diodes) maintain total isolation between them. A single output is wired to the critical load, which is then powered by the higher voltage source.

Isolation prevents the higher-charged battery from "dumping" into the lower charged or failed battery. Current is drawn automatically and continuously from the battery with the higher charge, so that there is no interruption of power if one of the batteries fails or becomes totally discharged.

The APS is rated for loads of up to 70 amps on 12-48 VDC systems. The unit is ruggedly constructed with heavy duty wiring studs and components in an anodized aluminum case.

Materials Provided

The APS is supplied with a hardware packet containing (4) hex nuts, (4) lock washers, (4) self-tapping mounting screws, (3) terminal insulation boots (P/N 710-0109-0), and (1) instruction manual. *Note:* Not all of the hardware will be used in the installation; some spares are provided.

IMPORTANT: Proper installation requires use of the correct (metric) hardware. If the hardware packet is missing or lost, please contact NEWMAR for a replacement. If you prefer to acquire hardware locally, request nut size **M-6** and compatibly sized washers. For marine applications use only non-corrosive hardware. Wiring hardware must be situated as shown below.

Wiring Hardware Configuration and Parts Supplied

QUANTITY SUPPLIED

NUT ASSEMBLY INSTRUCTION

3 pcs

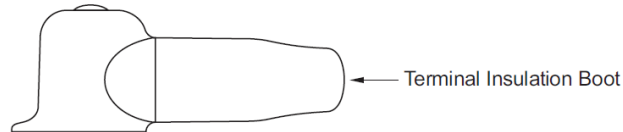

3+1 Spare

Hexagonal Brass Nut

Lock Washer

3+1 Spare

Ring Terminal w/Wire

Not Supplied

Terminal Post

Mounting Screw
4 (#10 x 1" S.S.
Phillips Pan Head)

φ6.0mm Terminal Post

Don't Loosen This Bottom Jam Nut
Factory Installed

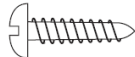

Terminal Plate



NOTE: Install hardware to the studs in the order as shown above.

Being careful not to loosen or over-torque the bottom hex or jam nut !

CAUTION: Failure to install hardware as shown above can result in product failure or system damage and Will void warranty!

Installation

Refer to the installation diagram on the reverse of this sheet.

1. Shut off all charging sources and disconnect the negative (ground) side of each battery which will be wired to the APS.
2. Mount the APS in a suitable location which will keep wire runs to a minimum length, and is (preferably) ventilated, for cooler operation. The case of the APS is electrically isolated from the internal diodes, so mounting on either a metal or non-metal surface is acceptable.

3. Obtain wires (stranded, not solid) of suitable length for the wiring runs, and terminate the ends with 6mm or 1/4" ring lugs (not supplied). Terminate the other ends as suitable for the load and battery. Refer to the Wire Size Table to determine the correct wire gauge (based on wire length).

4. Attach the wires to the load and batteries as shown in the installation diagram. Source and Load terminals are identified on a label on the side of the APS for further clarification. *Note:* It is always recommended to fuse wiring at the battery.

5. Reconnect the negative battery posts.

IMPORTANT NOTE ABOUT BATTERY SOURCES: Whenever the load is turned on, it can be drawing power from the batteries. Therefore, if the batteries are not simultaneously being recharged, or if charging will not be available for an extended period, it is recommended that the load be shut off to prevent complete discharge of batteries.

Wire Size Table

Note: WIRE LENGTH is the combined length of the wire run from the APS to the load and from the APS to the farthest battery.

WIRE LENGTH	WIRE SIZE (AWG)	WIRE SIZE (MM)
Up to 10'	# 6	16
10' - 25'	# 4	25
25' - 40'	# 2	35

Installation Diagram

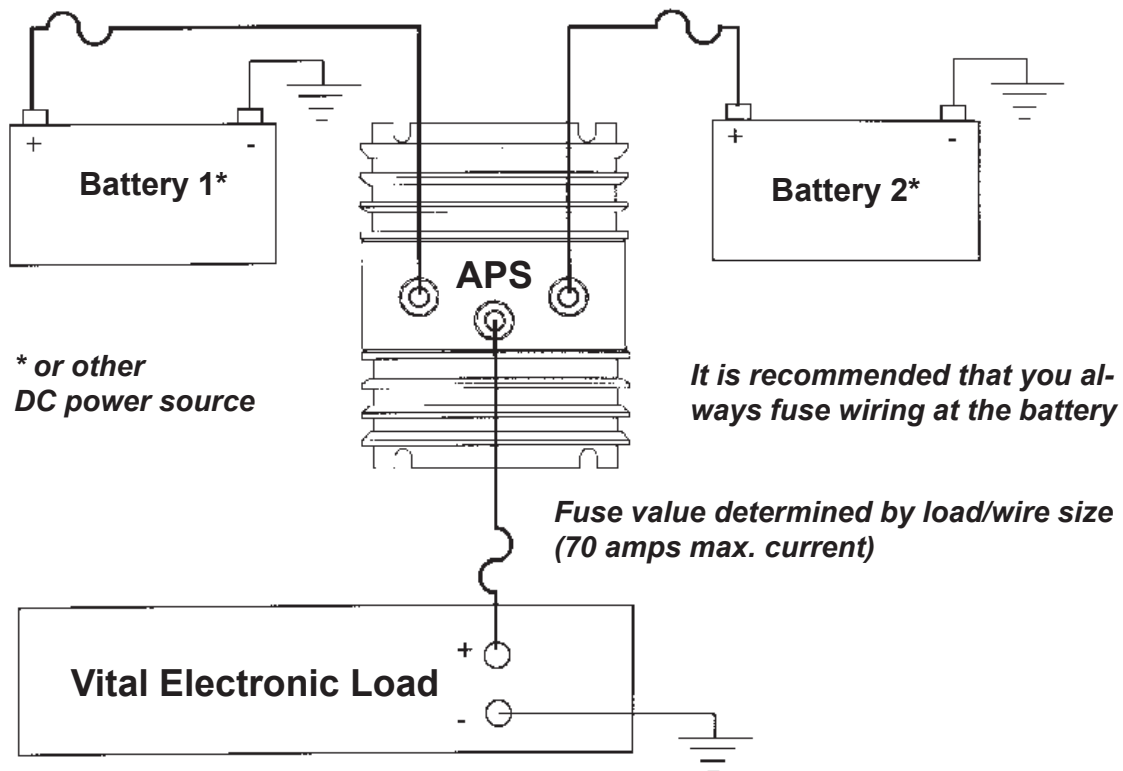

Specifications

Model: APS-70

Input Voltage Range: 6-50 VDC, negative ground

Maximum Load Current: 70 amps

Operating Temperature: -40° to +80° C; derate linearly from 100% @ 50° C to 70 % @ 80° C

Voltage Drop: Approximately .35 VDC @ 50 % load; .45 VDC @ full load

Dimensions: 3.66 " x 4.53" x 3.0" (9.3 x 11.5 x 7.6 cm)

NEWMAR
DC Power Onboard