

# Temperature Compensation Sensor

## Model: TCS-12/24

### Installation/Operation Instructions

The TCS is an optional remote sensor for optimizing the voltage output of your Phase Three charger based on ambient or battery temperature. It is designed for use only with the following models: PT-14, PT-20, PT-25, PT-40, PT-70, PT-24-8, PT-24-13, PT-24-20, PT-24-35, PT-24-40, as well as all PTM Series models.

#### I) Function / Purpose

Because low battery temperature increases resistance to charging and high battery temperature reduces resistance, the ideal charging voltage for a battery will vary depending on its temperature. (This depends primarily on the temperature of the battery's environment when it is being charged, but high rate charging for extended periods will also increase battery temperature.)

If a charger has a fixed output voltage which is ideal at, for instance, 72° F, that same output may cause a battery charged in a consistently high temperature environment to be over-charged, resulting in excessive loss or damage to the electrolyte. Conversely, if the batteries are in a consistently cool environment, they may be chronically undercharged, resulting in sulfation of the battery plates. Either of these two conditions will shorten battery life.

Therefore, the Phase Three charger is designed to utilize this optional remote sensor which provides automatic temperature compensation. The remote sensor will signal the charger to fine tune its output voltage so that it is properly matched to the temperature of the battery/battery environment. The adjustment rate is approximately -3 mV per cell per °F, or -5 mV per cell per °C.

#### II) Installation

*Caution:* There are two different TCS temperature sensor models. Prior to installing the TCS sensor, verify that you have the correct model, as the incorrect model will cause improper output voltage. The correct TCS model for all Phase Three Chargers is stamped with a "12" and a "24" on the metal face of the sensor. If it is not stamped, or if it is stamped "48", contact the factory before proceeding.

The remote sensor is provided with 30' of cable. One end of the cable is plugged into the temperature compensation jack which is located on the lower right side of the charger on some models or front of the charger on other models. The jack is identified on the front panel.

*Caution:* Plugging the TCS into the Remote Monitor Panel jack on the charger can cause output voltage instability on certain models. If the charger ammeter needle oscillates rapidly at the low end of the meter scale, check to be sure the TCS is plugged into the correct jack.

If additional cable length is required, additional cable is commonly available from most electronics supply retailers such as Radio Shack/Tandy. Request a 6 conductor modular-to-modular line cord (part number 279-422, 25 feet long) and 6 pin modular in-line coupler (part number 279-423).



ELECTRONIC POWER PRODUCTS  
COMMUNICATION • NAVIGATION

M44537680A  
As of DEC 2004

The sensor itself should be mounted inside the battery box, or more ideally, mounted onto one of the batteries using a clamp or a small amount of silicone-type adhesive.

Alternatively, if you have access to the exterior of a wall of the battery box, you may drill a hole in the wall (or lid) and run a screw through the wall and sensor to mount it onto the interior surface. The sensor has a hole in the center which will accommodate a # 6 screw. Use caution when drilling so that you do not accidentally puncture the case of any battery inside the box. Run the screw (with washer) through the box wall and the sensor and secure it with a lock washer and nut. (Length of screw depends on thickness of battery box wall.)

**Important note:** When wiring multiple units in parallel and using the temperature compensation option, you must use a separate sensor for each charger, and the sensors must be mounted close together in the same battery box or on the same battery for proper operation.

### Temperature Sensor Installation Options:

#### Attach Sensor Directly To Battery

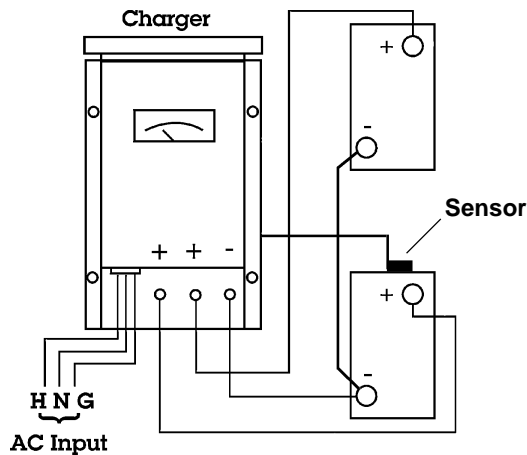

#### Attach Sensor to Inside of Battery Box

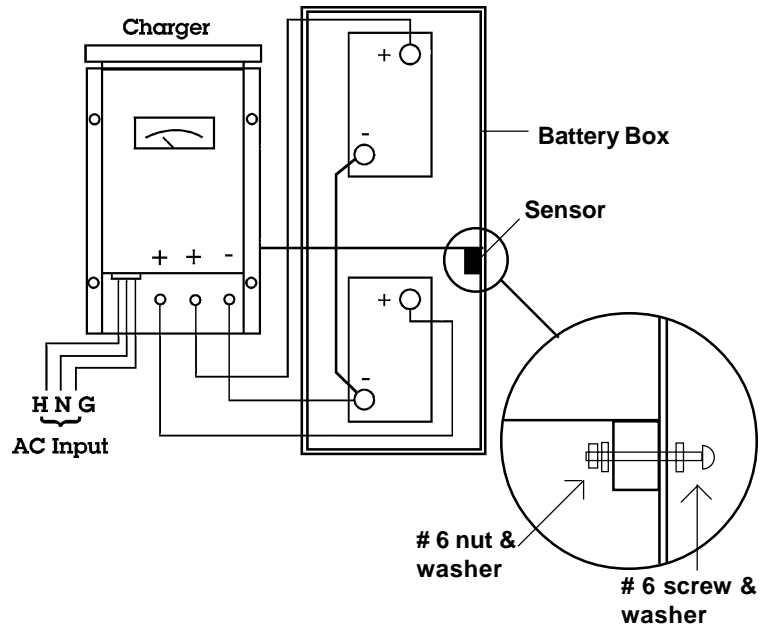

### III) Operation

Once installed and plugged into the charger, the operation of the temperature sensor is automatic and no adjustments or maintenance are necessary. *Note: If the sensor should become unplugged for any reason, output voltages will be as shown at 72° in the chart below, regardless of actual battery temperature.*

To illustrate the effect of the temperature compensation sensor on the output voltage of the charger, the chart below lists the charge/float output voltages of the charger at moderate (72° F), cold (50° F) or hot (90° F) battery temperatures with temp sensor installed:

#### Temperature Compensation Chart

| Battery Temperature |       | Output V.d.c : 12 Volt Models |           |          |           | Output V.d.c : 24 Volt Models |           |          |           |
|---------------------|-------|-------------------------------|-----------|----------|-----------|-------------------------------|-----------|----------|-----------|
|                     |       | Charge                        |           | Float    |           | Charge                        |           | Float    |           |
| ° F                 | ° C   | Gel-Cell                      | Lead Acid | Gel-Cell | Lead Acid | Gel-Cell                      | Lead Acid | Gel-Cell | Lead Acid |
| 50                  | 10    | 14.4                          | 14.6      | 14.0     | 13.8      | 28.8                          | 29.2      | 28.0     | 27.6      |
| 72*                 | 22.2* | 14.0                          | 14.2      | 13.6     | 13.4      | 28.0                          | 28.4      | 27.2     | 26.8      |
| 90                  | 32.2  | 13.7                          | 13.9      | 13.3     | 13.1      | 27.4                          | 27.8      | 26.6     | 26.2      |

\* Factory pre-set voltages without temperature compensation option installed



**ELECTRONIC POWER PRODUCTS**  
COMMUNICATION • NAVIGATION