



# OCTOPUS

SELECTION & INSTALLATION GUIDE



## **38mm BORE LINEAR ACTUATOR STYLES "LAM" & "LAR"**

### **A. GENERAL DESCRIPTION:**

The Octopus hydraulic linear actuator is a simple, efficient and reliable way of driving the rudder on vessels with mechanical steering systems. The unit is an assembly of an Octopus reversing pump and a marine hydraulic cylinder; it has a total of only 5 moving parts. The pump is a patented single radial piston design and the cylinder driving the rudder is a design proven in thousands of steering systems, and which gives minimal "drag" on the steering system. This assembly is mounted on the rudder quadrant and hull superstructure. When the autopilot is not in use (hand steering) the cylinder runs freely along with the rudder. When the autopilot is in use, a solenoid valve on the actuator closes and locks the cylinder. Steering signals from the autopilot are now fed to the dc motor which drives the pump to move the cylinder back and forth. De-energizing the solenoid valve immediately disconnects the automatic pilot from the rudder. The unit has a small translucent oil reservoir making it easy to check the fluid level, it is also shipped from our factory filled with oil and requires no additional hydraulic plumbing or purging.

### **B. SELECTION:**

Make sure that you have selected the correct model linear actuator. They are available in 2 voltages 12vdc & 24vdc, 2 strokes 178mm (7") and 305mm (12") and 2 styles (linear actuator mounted) LAM and (linear actuator remote) LAR. The LAM style has the pump unit mounted directly onto the cylinder, the LAR style has the pump remotely mounted from the cylinder, connected by 2 x 50cm long hoses. This LAR style is more flexible when installing a drive in a tight space. The first 2 characters in the model number are the abbreviated pumping capacity, the third and fourth characters are the voltage, the fifth, sixth & seventh characters are the style and the eighth (or eighth and ninth) is the stroke in inches. For installation geometry and envelope see diagrams A thru F.

### **C. INSTALLATION:**

Mount the linear actuator with the plastic reservoir upmost. Take note of the mid-position and necessary clearances for operating from full H.O. to full H.O., see diagrams A thru F. After mounting, swing the rudder from side to side to make sure that there is no binding in the cylinder or mountings. The rudder stops on the vessel should be set so that the cylinder does not "bottom out" at the ends of it's stroke. Make electrical connections according to the information supplied by the autopilot manufacturer. Access should be made to the unit for service purposes and care should be taken to prevent water from splashing or dripping onto the actuator. The unit is shipped with a white plastic sealing cap on the plastic reservoir; this should be REMOVED and REPLACED with the METAL VENTED cap attached by a nylon line to the valve block. Save the plastic cap in case the unit needs to be shipped for service in the future. If the unit is installed before construction of the vessel is complete, protect the unit (especially the cylinder rod) from dirt, paint and damage.

### **D. TOPPING UP & PURGING:**

The unit is shipped from the factory filled, tested and ready for service. It should run immediately on installation. If however the oil has been displaced during shipping, the unit may need to be topped up and re-purged of air before running. Re-purging may also be required if the unit has been inoperative for a long period or has been driven for extended periods by the rudder without using the autopilot.

<p style="text-align: center;"><b>SELECTION &amp; INSTALLATION GUIDE (Continued)</b> <b>38mm BORE LINEAR ACTUATOR STYLES “LAM” &amp; “LAR”</b></p>
--

**D1. TOPPING UP:**

Check the oil level occasionally and top up as required. Do not overfill. Use Shell Tellus 22 hydraulic oil or automatic transmission oil (ATF). Do not use thinner grades of oil such as are used in some hydraulic systems. The oil in the system will show some discoloration with use. This is quite normal. A film of oil will show on the cylinder rod - this is normal.

**D2. PURGING:**

DO NOT RUN THE PUMP DURING PURGING OPERATION

To purge air from the cylinder, proceed as follows:

1. Undo the 2 brass bleeder screws 2 TURNS ONLY. They are located on either side of the valve block just below the plastic reservoir.
2. Energize the solenoid valve coil.
3. Turn the steering wheel from full lock left to full lock right and back again for a few minutes. Air will be seen bubbling from the cylinder into the tank. Top up the oil level if needed. Stop the procedure when no more bubbles are observed.
4. Close the 2 brass bleeder screws firmly.

**E. SYSTEM OIL CHANGE:**

**E1. DRAINING:**

To drain the actuator for a system oil change, remove the actuator from the vessel. Remove the metal vented cap from the plastic reservoir and open the 2 brass bleeder screws (2 TURNS ONLY). Invert the actuator and drain the oil out whilst sliding the rod back and forth by hand.

**E2. FILLING:**

When filling, position the actuator the right way up (plastic reservoir uppermost) and ensure that the 2 brass bleeder screws are open (2 TURNS ONLY), fill the reservoir with oil whilst sliding the rod back and forth by hand. The oil will be drawn into the cylinder and the air will be seen bubbling into the plastic reservoir. Stop when the bubbles stop appearing and tighten the 2 bleeder screws firmly.

**F. SERVICE:**

The Octopus pump requires no routine service. The marine hydraulic cylinder requires no routine service. The fluid level in the system reservoir should be maintained. A complete oil change should be made about once every 3 years - more often if used for extended cruising. Check all electrical connections on a periodic basis.

**SELECTION & INSTALLATION GUIDE (Continued)**  
**38mm BORE LINEAR ACTUATOR STYLES “LAM” & “LAR”**

**G. TROUBLESHOOTING:**

If the unit fails to operate after installation is complete, check for the following common causes.

1. Motor does not run:

- i. No voltage applied to motor. (Check voltage at motor with voltmeter).
- ii. Autopilot not switched on correct setting. (Check autopilot manual).

2. Motor runs but pump does not move the rudder:

- i. System not filled with oil. (Fill and purge system).
- ii. Bypass valve open. (Check autopilot output for signal).
- iii. Pump adjustment set too low. (Adjust flow setting up).
- iv. Bleed screws not closed (tighten 2 brass screws on by pass valve body).
- v. Pump has been dismantled and not assembled correctly. (Ensure piston is not backwards).
- vi. U-cup seal failure. (Install new cylinder seal kit).

3. Excess oil leaking from front or rear of cylinder, along shaft:

- i. Shaft seal failure (inspect shaft for damage, including nicks, scratches, varnish/paint spots - install new cylinder seal kit and either repair or replace the shaft).

4. Shaft seizes into barrel and unit does not run freely:

- i. Shaft bent or rear gland damaged. (inspect shaft for straightness or damage and rear gland/trunnion for damage, also ensure integrity of structural attachment to hull - either repair or replace damaged parts).

**H. SPARE PARTS:**

The following parts are available as spares and are recommended for vessels undertaking extensive passages or when autopilot downtime must be kept to an absolute minimum.

- |  |                  |
|--|------------------|
| 1. 1.0L – 12V complete motor & pump assembly kit for 7” linears  | part # OC14SUK10 |
| 2. 1.2L – 12V complete motor & pump assembly kit for 12” linears | part # OC14SUK11 |
| 3. 1.0L – 24V complete motor & pump assembly kit for 7” linears  | part # OC14SUK13 |
| 4. 1.2L – 24V complete motor & pump assembly kit for 12” linears | part # OC14SUK14 |
| 5. 12V Type 1 motor module assembly kit for 7” & 12” linears     | part # OC14SUK20 |
| 6. 24V Type 2 motor module assembly kit for 7” & 12” linears     | part # OC14SUK22 |
| 7. 1.0L pump module assembly kit for 7” linears                  | part # OC14SUK23 |
| 8. 1.2L pump module assembly kit for 12” linears                 | part # OC14SUK24 |
| 9. Solenoid valve cartridge                                      | part # OC1712    |
| 10. Solenoid valve coil 12 volt                                  | part # OC1713    |
| 11. Solenoid valve coil 24 volt                                  | part # OC1714    |
| 12. Reversing pump seal kit                                      | part # OC14SUK26 |
| 13. 38mm bore cylinder seal repair kit                           | part # OC16SUK08 |
| 14. #8 by-pass valve seal kit                                    | part # OC17SUK25 |
| 15. 3/8 SAE Hose Assembly x 24” (LAR style linears)              | part # OC1621    |
| 16. 3/8 SAE Hose Assembly x 12.5” (12” LAM style linears)        | part # OC1622    |
| 17. 3/8 SAE Hose Assembly x 10” (7” LAM style linears)           | part # OC1623    |

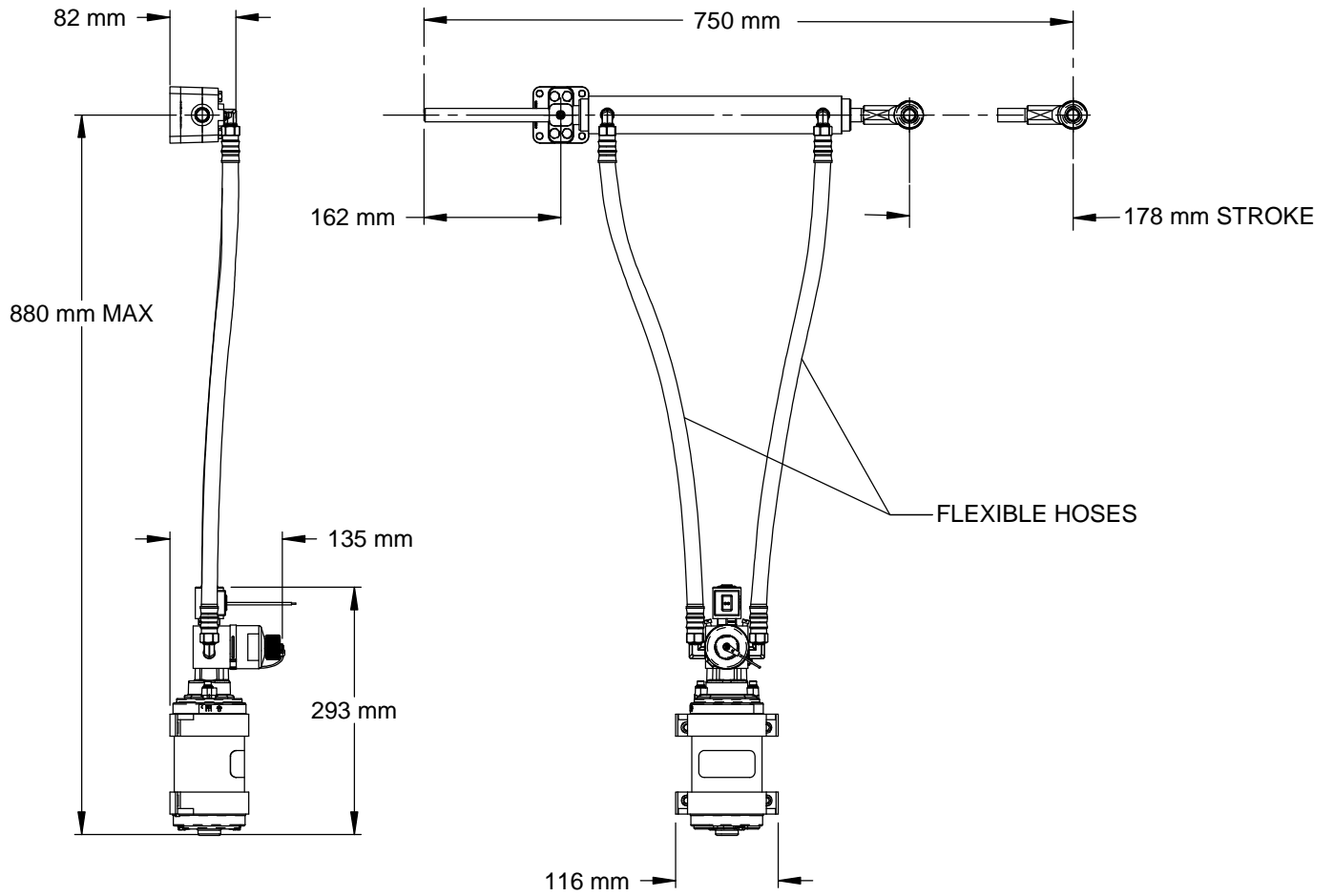

OCTOPUS PRECISION PRODUCTS INC.

TITLE  
 INSTALLATION ENVELOPE DIMENSIONS  
 FOR  $\phi 38$  mm BORE 7" (178 mm) STROKE  
 LINEAR DRIVE - REMOTE STYLE

PID #	REVISION	PAGE	DRAWN	DATE DD/MMM/YYYY	SCALE
OCTAF1012LAR7	NEW	N/A	LAURENTIU BUCUROIU	17/JUN/2002	1 : 8

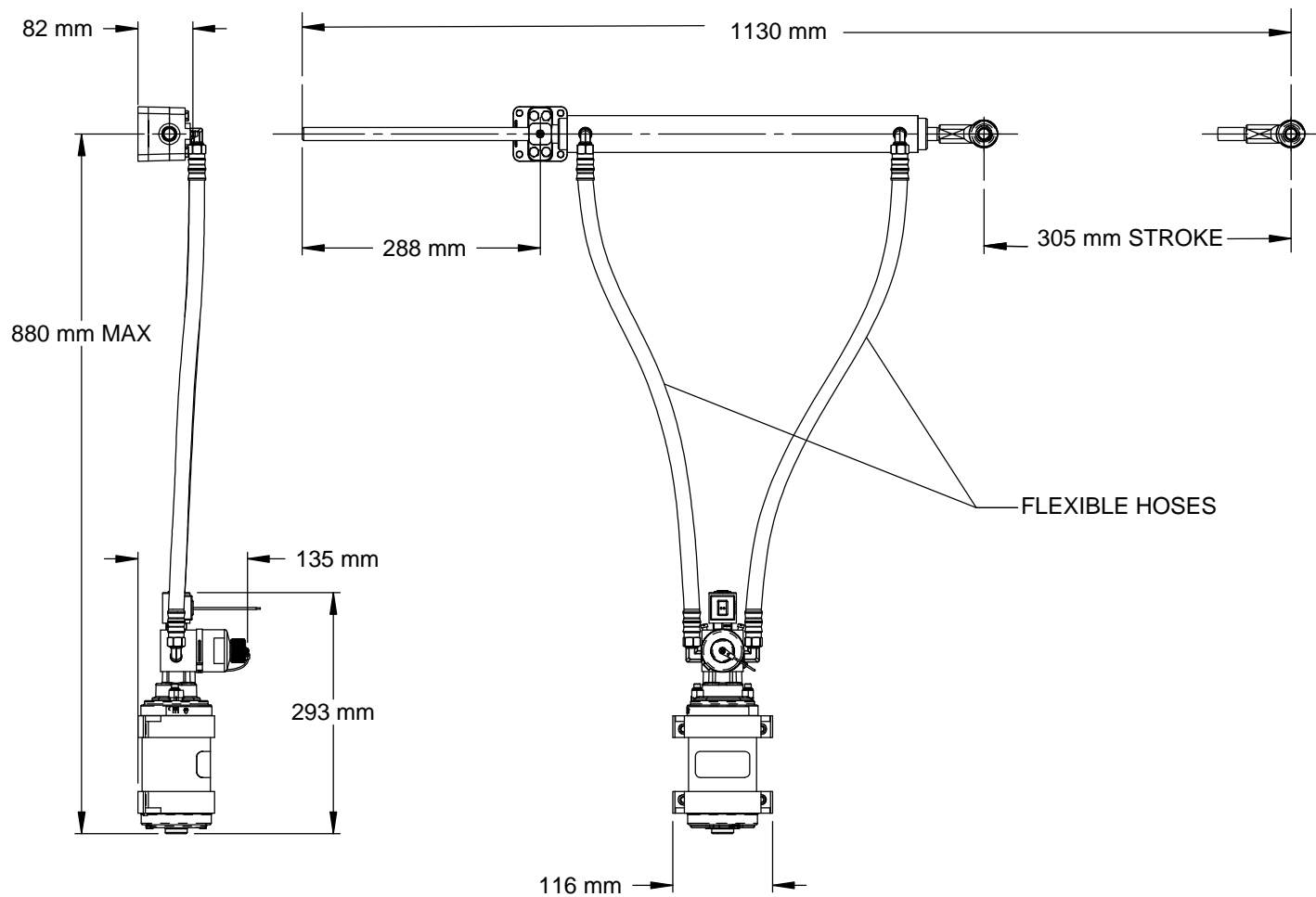

OCTOPUS PRECISION PRODUCTS INC.

TITLE INSTALLATION ENVELOPE DIMENSIONS  
FOR  $\phi 38$  mm BORE 12" (305 mm) STROKE  
LINEAR DRIVE - REMOTE STYLE

PID #	REVISION	PAGE	DRAWN	DATE DD/MMM/YYYY	SCALE
OCTAF1212LAR12	NEW	N/A	LAURENTIU BUCUROIU	18/JUN/2002	1 : 8

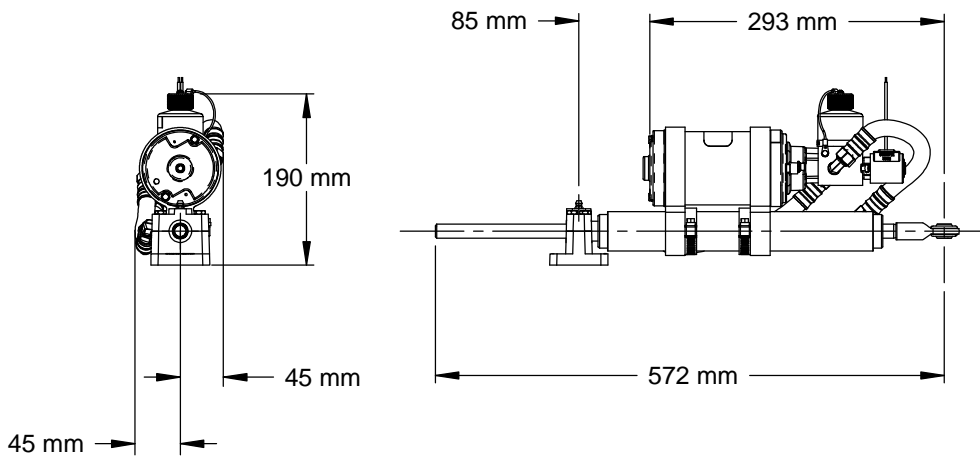
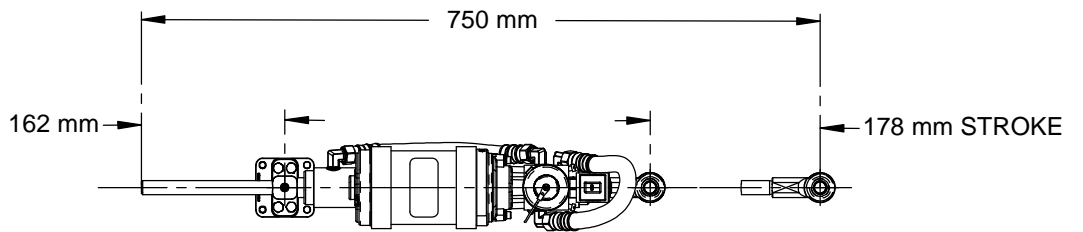

OCTOPUS PRECISION PRODUCTS INC.

TITLE  
 INSTALLATION ENVELOPE DIMENSIONS  
 FOR  $\varnothing 38$  mm BORE 7" (178 mm) STROKE  
 LINEAR DRIVE - MOUNTED STYLE

PID #	REVISION	PAGE	DRAWN	DATE DD/MMM/YYYY	SCALE
OCTAF1012LAM7	NEW	N/A	LAURENTIU BUCUROIU	18/JUN/2002	1 : 8

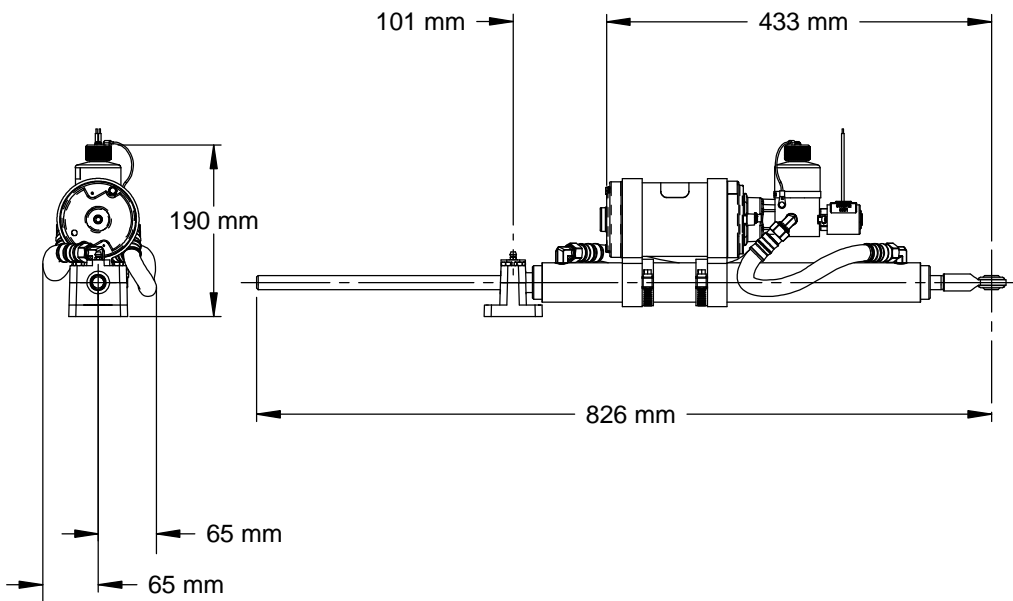
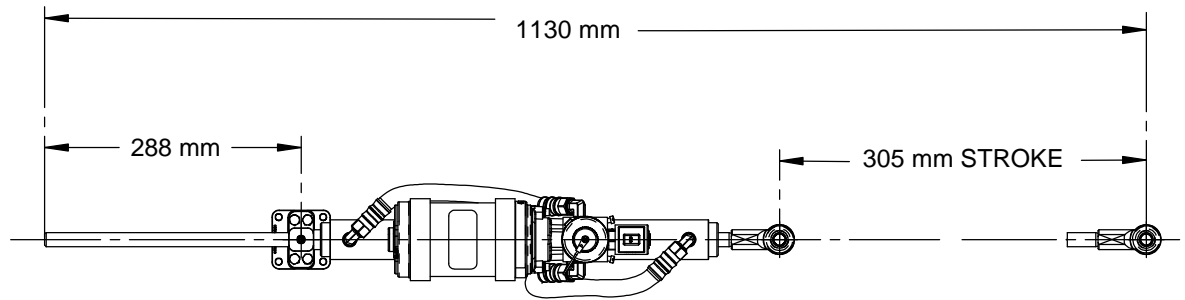

OCTOPUS PRECISION PRODUCTS INC.

TITLE  
 INSTALLATION ENVELOPE DIMENSIONS  
 FOR  $\phi 38$  mm BORE 12" (305 mm) STROKE  
 LINEAR DRIVE - MOUNTED STYLE

PID #	REVISION	PAGE	DRAWN	DATE DD/MMM/YYYY	SCALE
OCTAF1212LAM12	NEW	N/A	LAURENTIU BUCUROIU	18/JUN/2002	1 : 8

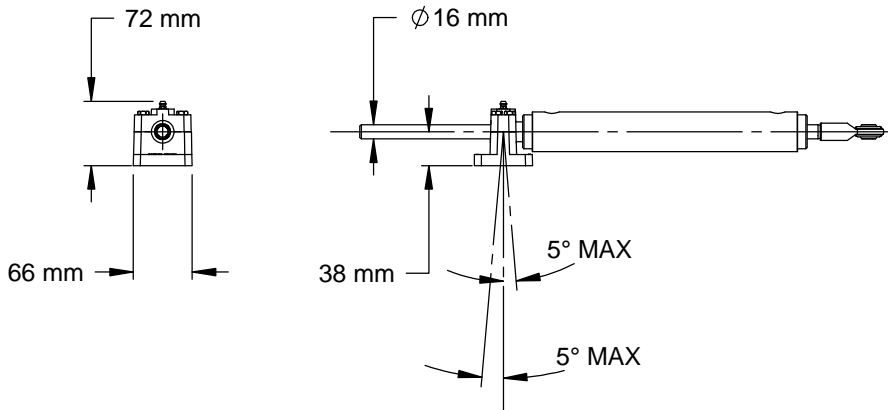
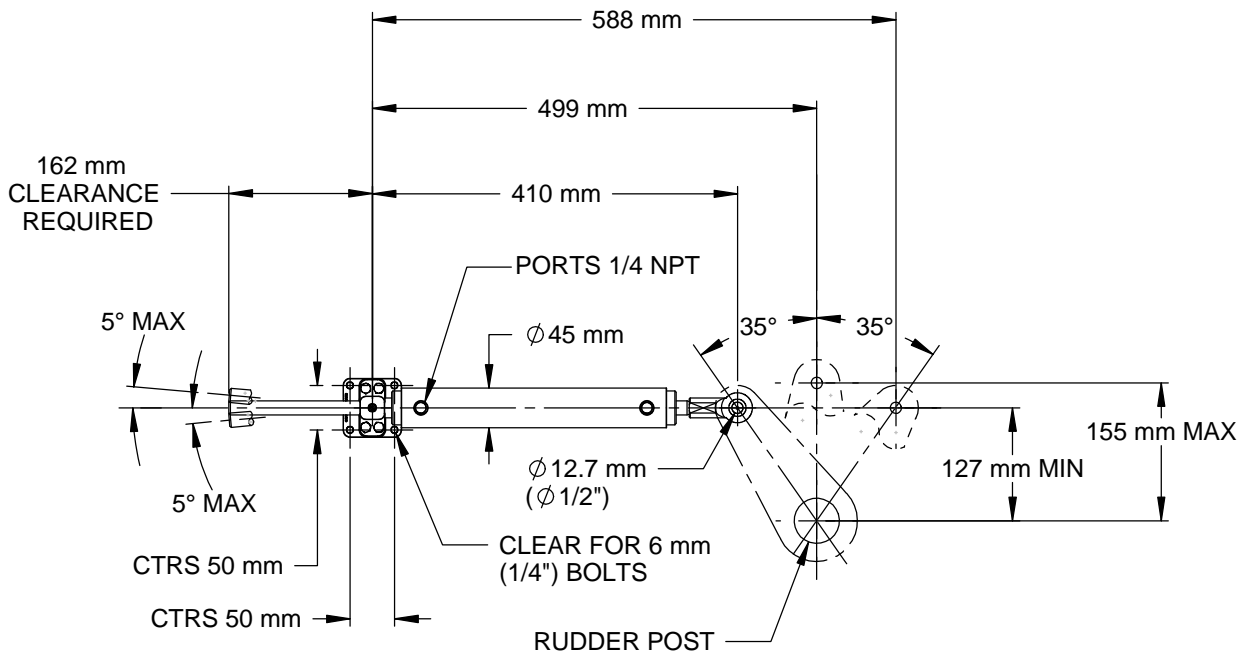

OCTOPUS PRECISION PRODUCTS INC.

TITLE					
MOUNTING DIMENSIONS & GEOMETRY FOR Ø 38 mm BORE LINEAR DRIVE MODELS LAM & LAR					
PID #	REVISION	PAGE	DRAWN	DATE DD/MMM/YYYY	SCALE
OCTAF1012LAM7 OCTAF1012LAR7	NEW	N/A	LAURENTIU BUCUROIU	02/AUG/2002	1 : 8



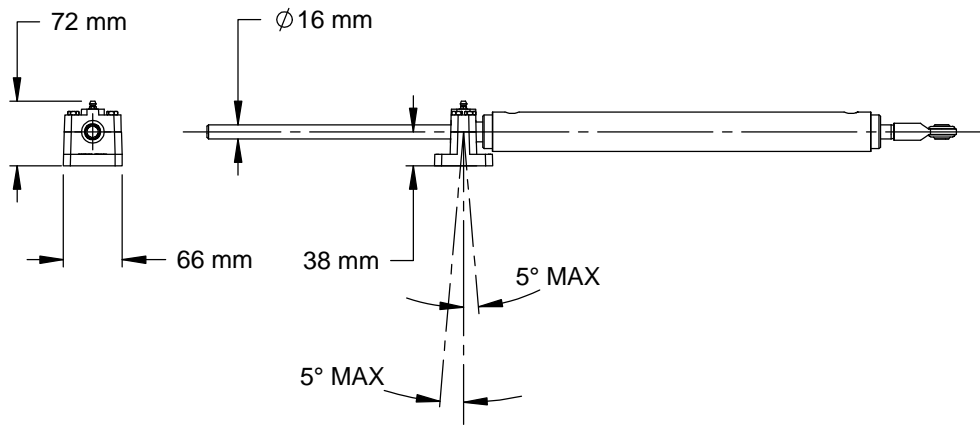
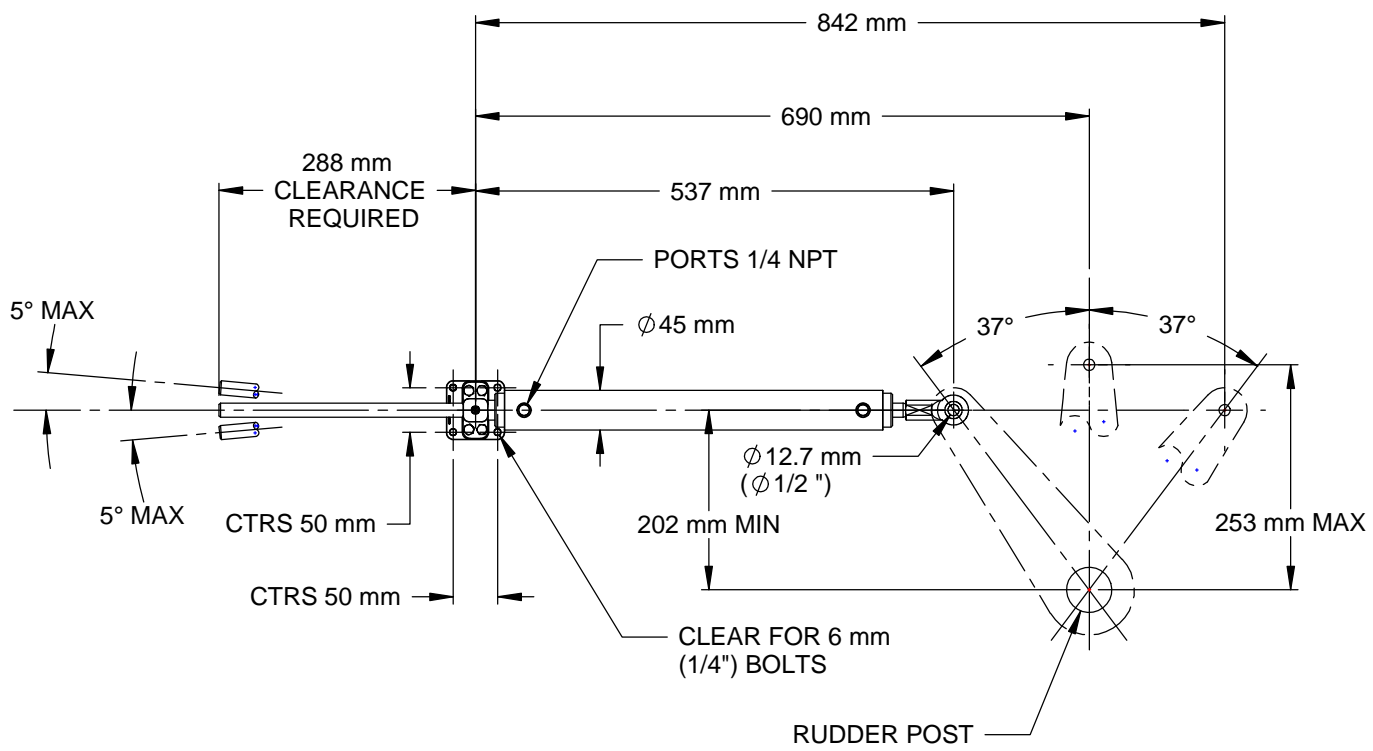

OCTOPUS PRECISION PRODUCTS INC.

TITLE MOUNTING DIMENSIONS & GEOMETRY FOR  $\phi 38$  mm BORE LINEAR DRIVE MODELS LAM & LAR

PID #	REVISION	PAGE	DRAWN	DATE DD/MMM/YYYY	SCALE
OCTAF1212LAM12 OCTAF1212LAR12	NEW	N/A	LAURENTIU BUCUROIU	06/AUG/2002	1 : 8