



**MARINETECH
PRODUCTS, INC.**

Safe-Skeg

MODEL 35-SS645



Mercury 150 HP Optimax, 2014
Suzuki 150-175-200-225 HP, 2-stroke, 1986-2002
Suzuki 150-175-200-225 HP, 4-stroke,, 2003-present
Suzuki 250SS & 300, 4-stroke, 2006-2011
Yamaha 115-130HP, 2-stroke, 1984-2002
Yamaha 150 HP, 2 and 4-stroke, 1984-present
Yamaha 115175-200-225-250 HP, 2-stroke, 1984-2002
Yamaha 350 HP, 4-stroke, 2009-present
Yamaha I/O 3.0L thru 5.7L, 1989-1993

DIMENSIONS

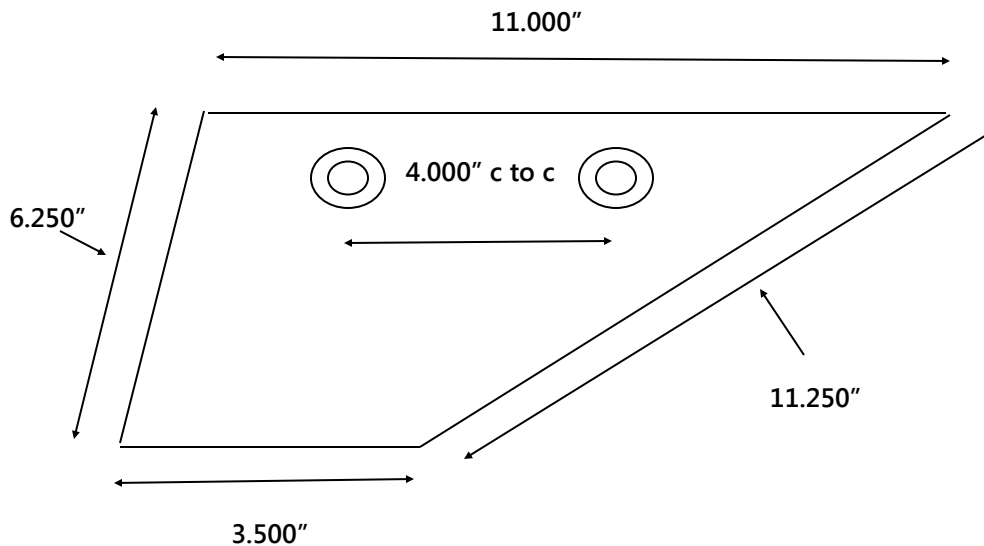

Made of 316 Marine Grade Stainless Steel
Thickness: 1.5 mm

Typical thickness of skeg
.625"

When it comes to quality boat hull and keel protectors, Panther is the brand you can depend on.