



ASSEMBLY INSTRUCTIONS

Congratulations on your new Patriot Dock purchase. This manual contains instructions to assemble basic dock configurations for use along a typical residential shoreline. Please read through entire instructions before starting.



General Guidelines:

- * Wear protective gloves and appropriate safety glasses when assembling the Patriot Dock.
- * **The maximum unsupported span for Patriot Aluminum Dock Frames is 16 feet, in the water or while in storage.** The dock is designed to carry a maximum of 500 pounds over any 4 ft x 4 ft part of the deck and a maximum of 1000 pounds between supports spaced 16 feet apart. Always support outside corners and use additional supports in high traffic areas or where greater loads are expected. **Please see the recommended support locations depicted below.**
- * Never push or pull the aluminum dock with a winch, ATV or vehicle.
- * Always remove decking panels and raise pipes not supported by wheels when pulling the frame in or out of the water.
- * Docks are not to be left in freezing water.
- * All dock surfaces can be slippery when wet. Please use caution when stepping or walking on any dock surface.
- * The dock should have no unsupported span greater than 16 feet while in use or while in storage.
- * Never leave the lake end of the dock unsupported. Always support corners of the Patio platform.
- * Roll-in kits should be installed at the very end of the dock for best stability. Additional posts may be required if roll-in kits are installed at locations other than what is recommended.
- * Always assemble the dock frame so there is a 4 ft. Truss End Rail (PN 10803) every 4 feet and at both ends of the dock. Patio sections must be closed on both ends using the 4 ft. Truss End Rail.
- * Install flat Transition Plates when connecting two 8 ft. frame assemblies (bottom only). Transition Plates are not required at joints with support legs.
- * Patriot docks are modular allowing for the flexibility to add length or change the configuration as desired. Additional parts may be required for certain configurations.

Tools Required: 1/2" , 9/16" and 3/4" Wrenches or ratchet w/ sockets, mallet

Recommended Tools: Cordless Impact wrench / drill with above socket sizes, work gloves, safety glasses

Support Locations

Standard Pipe Lengths:

< 16' = 4' pipe

17'- 32' = 6' pipe

33'+ = 8' pipe

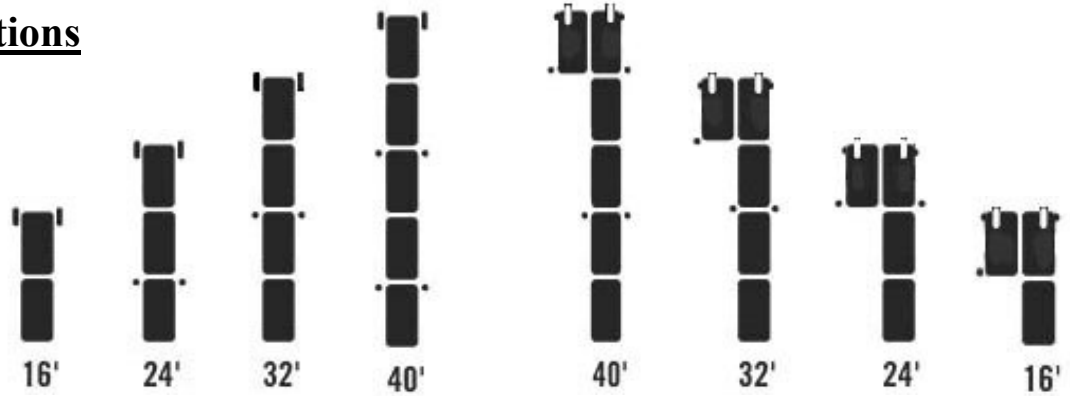

Parts List

PN10800 Aluminum Frame 4'x8'

1. (2) 4' Truss End Rail
2. (1) Left Side Rail
3. (1) Right Side Rail
4. (1) Connecting Rail
5. (1) Short SHORE END Center Support Tube (47")
6. (1) Long LAKE END Center Support Tube (48")
7. (1) 8' Diagonal Brace (8'x 1"x 1" angle) (not shown)
8. (1) Transition plate (17.5"x 1.5" flat bar) (not shown)

Assembly Hardware

- A. (20) 3/8"-16 x 1.25" Bolt
- B. (2) 3/8"-16 x 1.5" Bolt
- C. (22) 3/8"-16 Nut

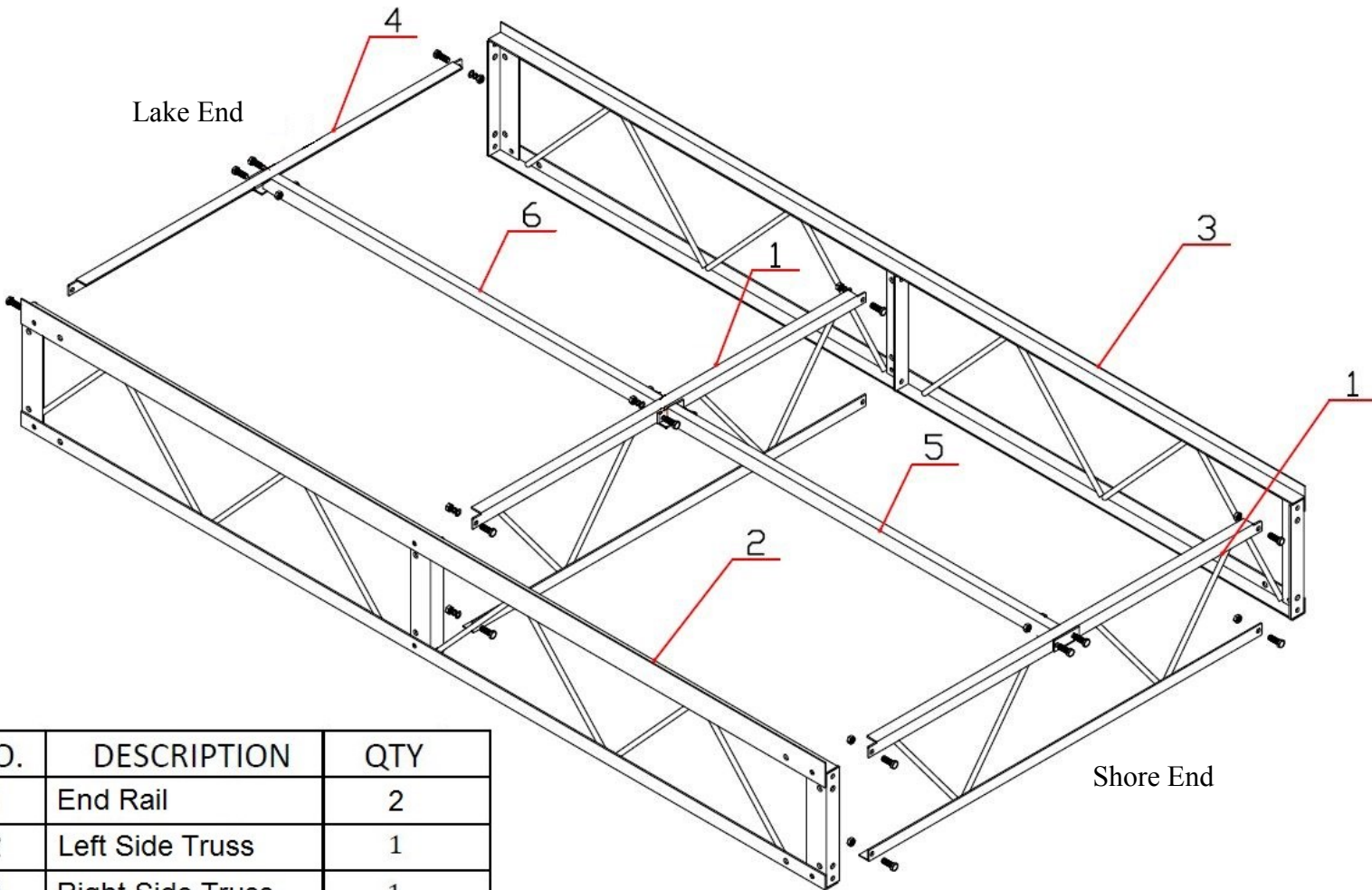

NO.	DESCRIPTION	QTY
1	End Rail	2
2	Left Side Truss	1
3	Right Side Truss	1
4	Connecting Rail	1
5	Short Center Tube	1
6	Long Center Tube	1

Patriot Dock Assembly

Helpful Hints for Patriot Dock Assembly:

1. Visit patriotdocks for step-by-step photo and video instructions under the Instructions and FAQ sections.
2. Each frame section is NOT built individually. Each additional section is attached and built off of the previous section.
3. Do not tighten any bolts until the frame or frames are fully assembled.
4. The 4 ft. Truss End Rail and Connecting Rail (Items 3 and 4) always fit **inside the vertical angles** of the 8' Side Rails.
5. Use the shorter 3/8" –16 X 1.25" bolts (Item A) for all joints **except** the center of the Connecting Rail (Item 4), where the two 3/8" –16 X 1.50" bolts are used (Item B).

Frame Assembly Steps (diagrams on page 4 and 5):

- Layout all the 4 x 8 ft frame components on level ground. Orient the components so the Short Center Support Tube (Item 5) is on the shore end of the frame and the Long Center Support Tube (Item 6) is on the lake end of the frame. See drawings for reference.
- Starting with the shore end of the frame, loosely bolt the 4 ft Truss End Rail (Item 1) to the Left and Right Side Rails (Item 2 and 3) using the 3/8"x1.25" bolt and nut. **Note: The lip on the side rails face upward. Notice the orientation of the center vertical angle on the Side Rails, this determines Left and Right sides.**
- Bolt the second 4 ft Truss End Rail (Item 1) at the center of the two Side Rails.
- Bolt the Short Center Support Tube between the two End Rails on the shore end of the frame. **Do not install the 3/8" nuts until after the next step.**
- Bolt the Long Center Support Tube between the middle 4' Truss End Rail (Item 1) and Connecting Rail (Item 4) using the 3/8" x 1.25" long bolts. **Wait to install 3/8" nuts until after next frame section has been joined to the first.**
- Connect the next 4 x 8 ft frame by fitting the two Side Rails and 4 ft Truss End Rail into the bolts from the previous step and install the 3/8" nuts to fasten the joint. See drawings on next page.
- Finish attaching the remaining 4 x 8 ft frames by repeating steps above. Repeat until the entire straight frame is assembled.
- Lastly, install the loose 4 ft Truss End Rail (Item 1) to the lake end of the straight length dock frame (shown in red on next page). Tighten all bolted connections throughout the dock assembly.
- Rotate dock frame on its side or prop up frame on blocks to install Transition Plates (Item 8) and 8 ft Diagonal Braces (Item 7) in the holes on the bottom of the assembled frames. The Transition Plates strengthen the connection between 4 x 8 ft connecting frames. The Diagonal Braces are installed under each 8 ft frame, alternating directions on each frame. The braces will form a Z type pattern under the frame to control swaying.
- If your dock has a Patio or "L" configuration, preassemble the 4 x 8 frame and connect to the straight dock section using six 3/8" x 1.25" bolts and nuts.

Pipe Supports (see page 6 for illustrations):

Fasten Pipe Supports to the frame, making sure there is no span greater than 16 ft. between supports.

Pipe Holders mount to the 1/2" holes in the vertical angles of the Side Rails. Insert pipe through Pipe Holder to desired height. Fasten Foot Plates to the bottom and add the pipe cap to the top. For Roll in pipe docks, install axle convertor (L-shaped unit) to the bottom of the vertical pipes. The Axle Converter should be oriented to that the closed sleeve accepts the vertical pipe and the through sleeve accepts the axle pipe. Orientate the "L" brackets inward. Feed horizontal axle pipe (6' for straight docks and 8' for patio docks) through both Axle Converter brackets. Add wheels and secure with stop clamps. Drill up to four 3/8" holes on one side of each wheel, at any of the 4 dimple locations, so wheel fills with water .

Add Decking:

- Drop in 4' x 4' decking panels after dock assembly is in the water and the height is adjusted. If you purchased aluminum dock panels, install adhesive backed rubber to the top of the side rails and the center of the frame before installing the deck panels.
- Use the optional Deck Locker or add your own locking screws, bolts or zip ties to fasten the decking panels to the frame using the single hole in the stringers (poly and aluminum decking) if desired.
- Remove decking before moving the dock frame out of the water for storage. Stack and cover the decking for protection in the off season.

DO NOT assemble frames individually. Join frames together while assembling. Assembly hardware passes through the lake end of the first frame and through the shore end of the next frame.

The 4' Truss End Rail on the lake face of the dock (marked in red) is not included in the PN10800 Frame Assembly.

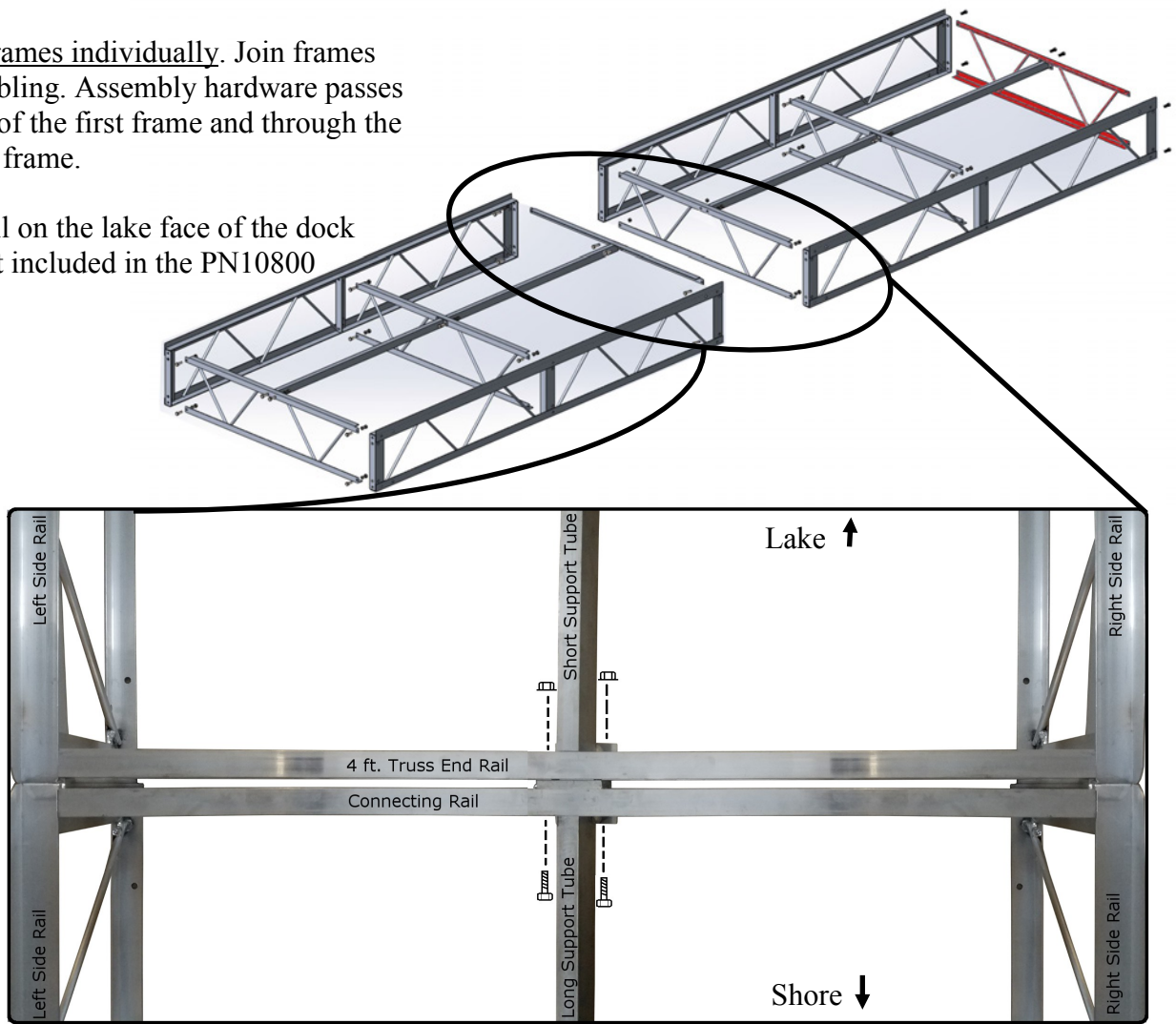

ABOVE: Top view of two frames being joined together.
Assembly bolts pass through all aluminum components being joined together.
See diagram on next page for further joint details, including Diagonal Brace and Transition Plate installation.

After straight run of pier is assembled, patio sections can be added.
Assemble patio section completely. Bolt parallel to straight pier using six 3/8" bolts.

Terminal ends of completed pier are always to be finished with a 4' Truss End Rail (shown in red).

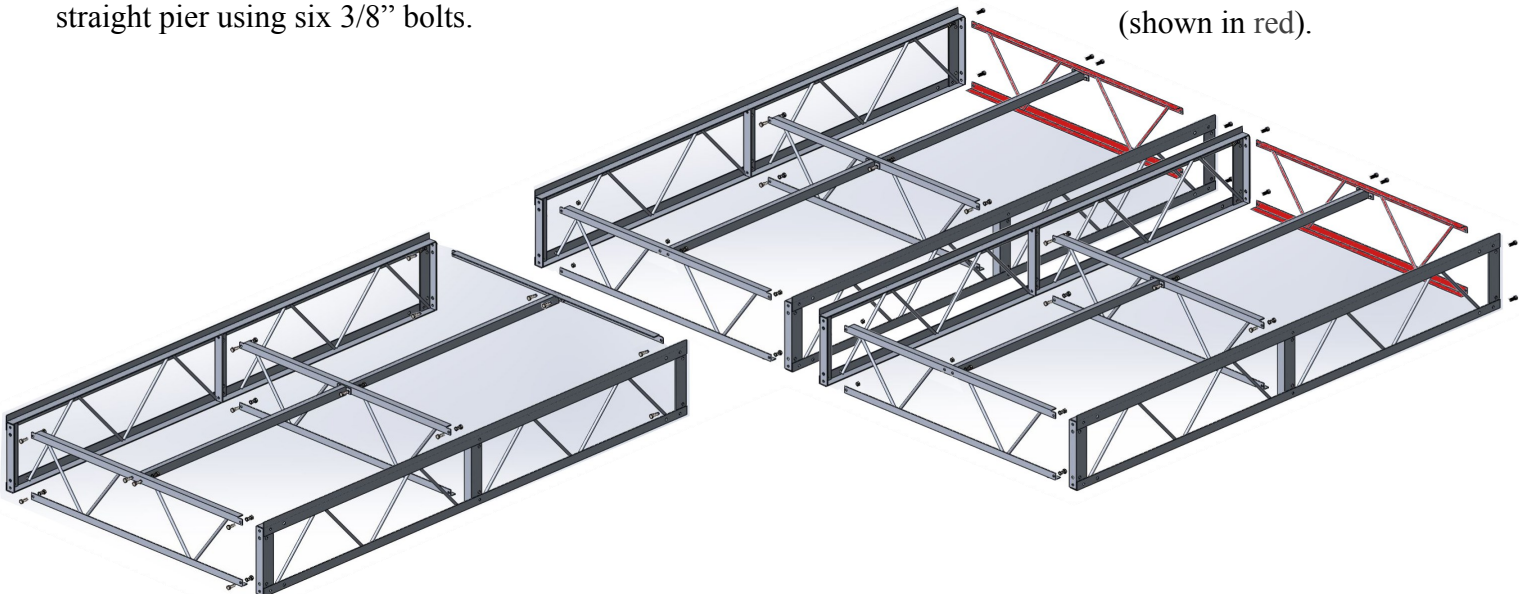

The Diagonal Braces and Transition Plates share the same mounting holes and assembly bolts. The Diagonal Braces should alternate direction on each frame, creating a zig-zag pattern.

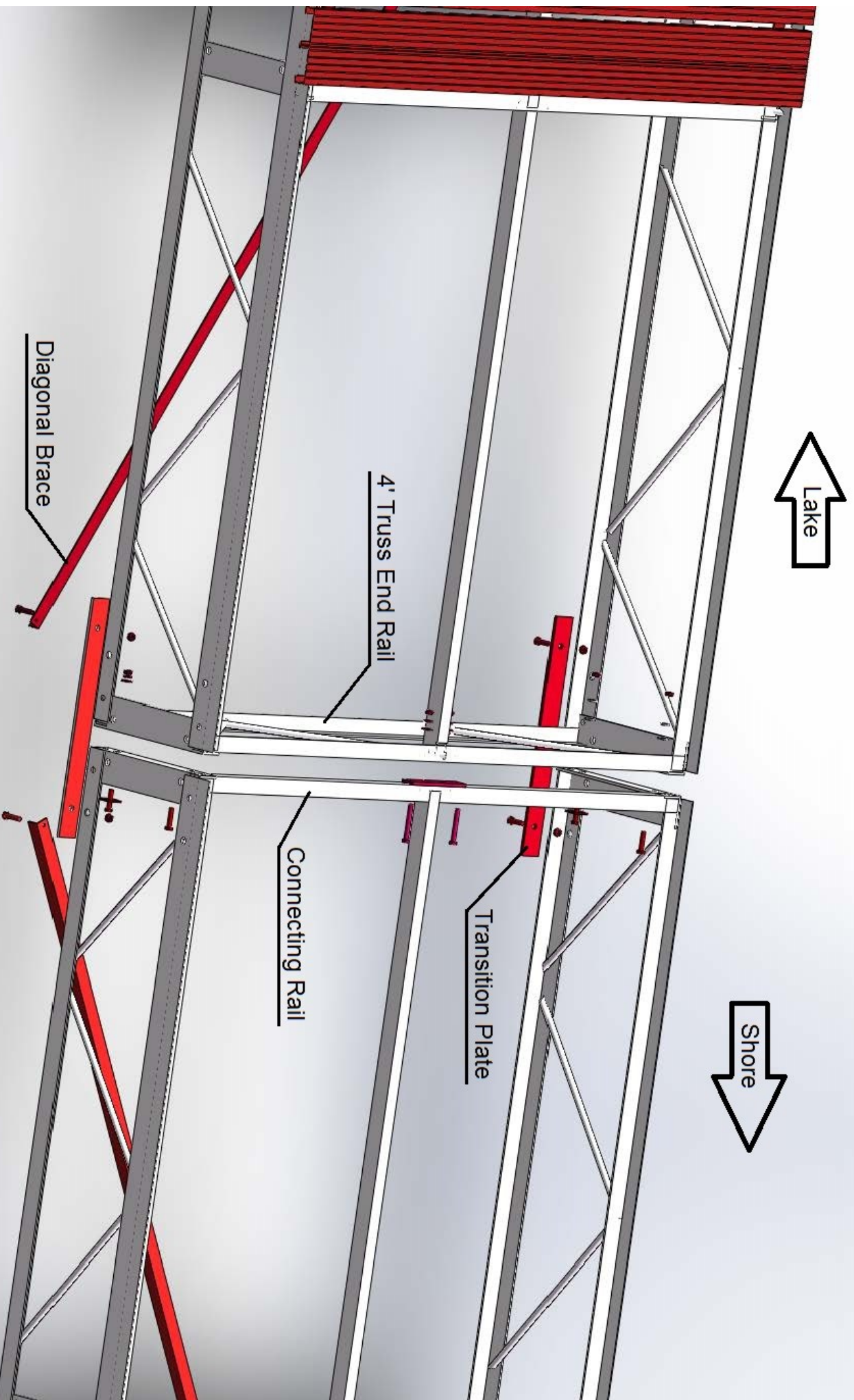

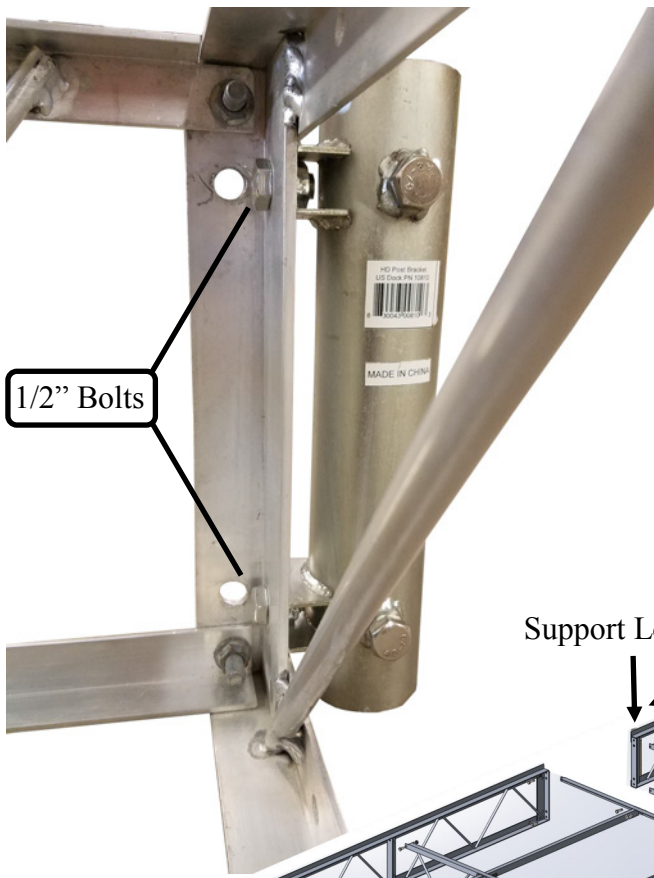

1/2" Bolts

Pipe Supports

Install Post Bracket using two 1/2"x 3/4" bolts. (included with Post Bracket)

Loosen set bolts, install 1-1/2" i.d. schedule 40 support pipes and add Pipe Caps and either Foot Plate bases or the axle components.

NOTE: There must be no more than a 16 ft. span between supports!

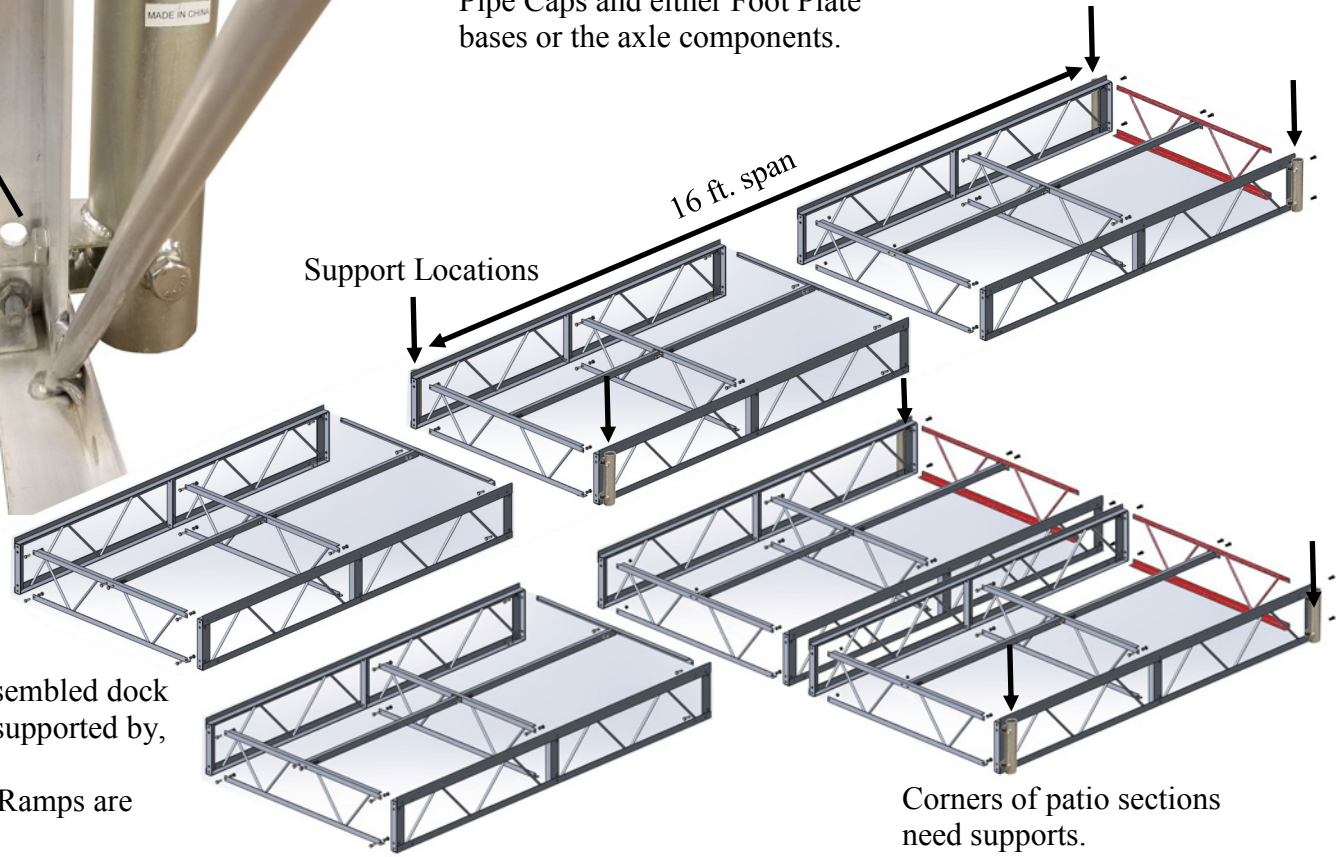

Shore end of assembled dock rests on, and is supported by, the shoreline. Optional Shore Ramps are available.

Corners of patio sections need supports.

For pipe axle assembly, install Axle Converter pieces to a set of vertical support pipes (the shorter, closed off leg of Axle Converter receives the vertical pipe). Install axle pipe (6 ft. pipe used with 4 ft. wide docks and 8 ft. pipe used with 8 ft. wide docks) through the horizontal leg of the Axle Converter pair (On 8' axles, install Stop Collars between Axle Converter pair). Add wheels and secure in place with Wheel Stop Collars.

**Wheels are orientated outward on 4 ft. wide docks.
Wheels are orientated inward on 8 ft. wide docks.**



Decking Installation

Lastly, after the dock has been assembled completely, installed in the water and leveled throughout, then the pier is ready for the decking to be installed. The most efficient way to set the decking in place is to start at the shore end of the dock and set each panel in place, working towards the lake end. Removal is the opposite of installation.



After Rubber Insulator is applied, the Aluminum Decking can be set in place.

Optional Deck Lockers can be installed on the panel to secure the decking to the frame.

Sold Separately

When assembling the poly decking, lay out the 1'x4' poly deck boards parallel to each other creating the 4'x4' shape. Spacing of each 1'x4' poly deck board is approximately 5/8". Spacing is pre-determined by hole placement.

Place aluminum stringer onto the deck boards and line up holes in the stringer with the pre-drilled holes in the poly deck boards. Secure stringer with 1" long pan head screws

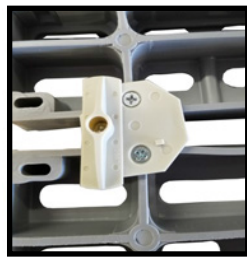

PN10867: Deck Locker

Use the optional Deck Locker to secure the 4x4' poly deck panel onto the dock frame.

Sold Separately



When installing Aluminum Deck Panels, first apply the adhesive backed Rubber Insulator to the aluminum frames. The Rubber Insulator is installed down the length of the 8' Side Rails and down the length of the Center Support Tubes. **(Only used with aluminum deck)** **The Rubber Insulator is not to be installed in the direction of the 4 ft. width, only lengthwise.**

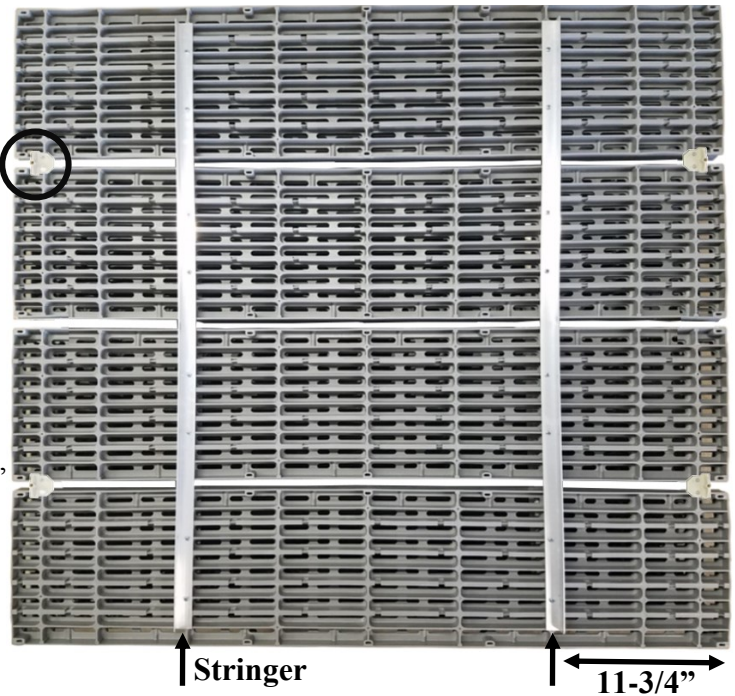
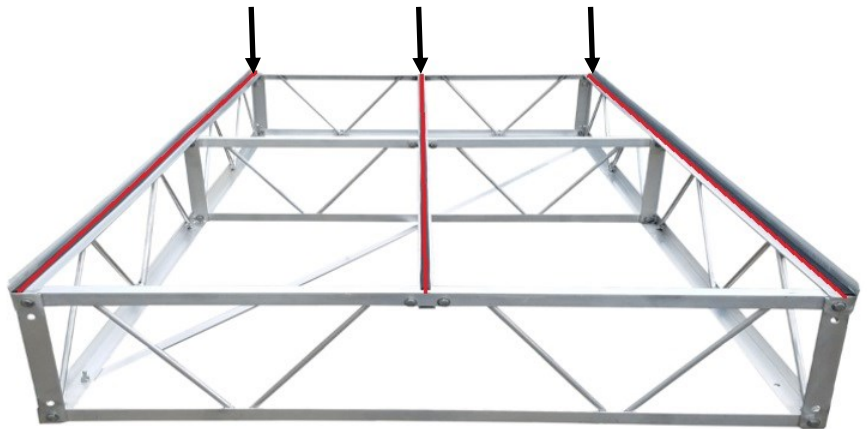

The Cedar Deck Panel is simply set in place. The cedar panels are sold untreated and can be installed as is. To extend the service life of the cedar deck, a water repellent stain can be applied. The Cedar Decking does not utilize a deck locker mechanism but it is recommended that the panels be secured to the frame in some capacity. (zip-ties are commonly used)

Check out the collection of docking products we offer.