



aerospace
climate control
electromechanical
filtration
fluid & gas handling
hydraulics
pneumatics
process control
sealing & shielding



Racor Filter Division Europe

Marine Filtration Systems and Solutions



Racor Marine Filtration Solutions

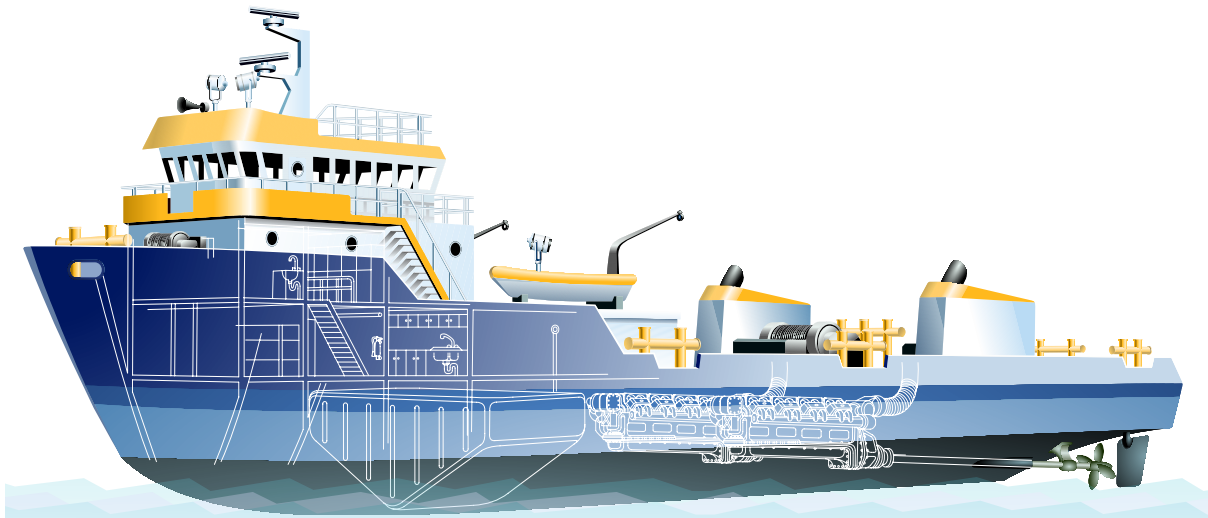

For more than 40 years, more vessels have put out to oceans, rivers and lakes with protection from the most trusted name in the business... Racor.

Racor offers a complete range of filtration products that are as efficient as they are reliable. And for every product you see here, there are dozens of complementary models with capacity and features suited precisely for your systems and working conditions.

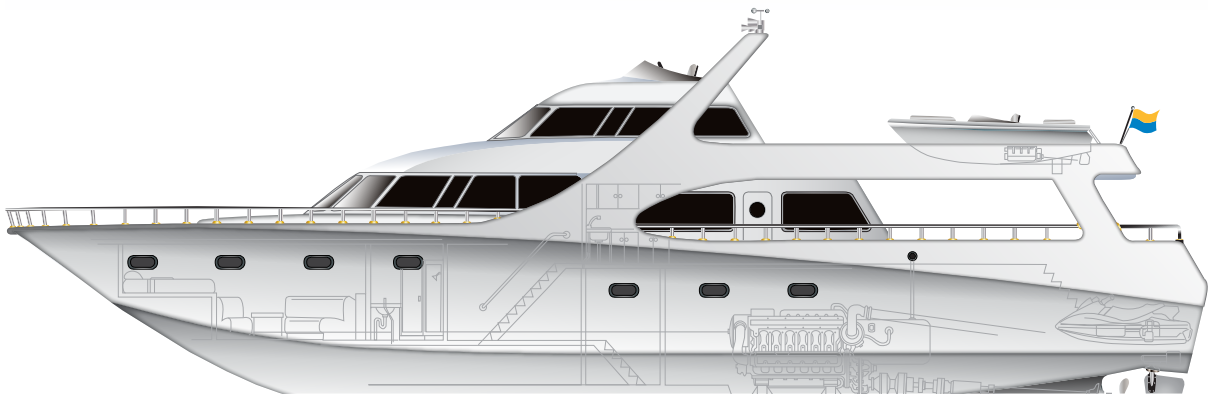

Ask a sailor about engine protection, about filtration or about reliability and performance. Whether they are a captain of a superyacht, sailboat, fishing boat or tug, the chances are the one-word answer will be the same as it has been for over four decades...Racor

Delivering the quality and reliability mariners most respect is a customer-driven effort at Racor.

We view every marine vessel, and the sailors who depend upon them for livelihood or leisure, as a personal responsibility.

Products that are the result of computer-aided design and stringent manufacturing processes, solidly built to withstand the rigors of the marine environment. This commitment to uncompromising quality has earned Racor a global reputation as the most trusted name in engine protection.

Table of Contents

Genuine Racor Filters	4
Water Separation Efficiency	5
Fuel Filtration	6
Marine Turbine Series	9
Fuel Polishing Module	12
Filter Funnels	12
800 Series (804,806,812)	13
Diesel Spin-On Series	14
Marine Small Craft	16
High Flow Spin-On	17
Fuel Conditioning Module	18
Marine Gasoline Series	19
FBO and Duplex FBO Series	21
FBO Fuel Filter Trolley	23
HiFlo Fuel Filtration	24
RVFS Series	25
Crankcase Filtration	26
Total Air Intake Solutions	28
Air Filter/Silencer	30
LG50 and LG100	31
Oil Bypass Filtration	32
Filtration Accessories	34
Water Detection Modules & Kits	35
Water Detection Probes	36
Racor Water Makers	37
Master Control Panel	37
SW Series	39
PW Series	40
Bilge Water Membrane Separators	41



If It's Not A Genuine Racor Filter,

you could be asking for trouble...

Issue	Concerns With Competitor Copies	Racor Commitment to Quality
Blocked Filter	Low quality media will perform poorly and can block 70% sooner than Racor media.	Racor uses propriety Aquabloc® media that meets or exceeds water removal and particle efficiency requirements for OEM fuel injection systems.
Bypassing	Poorly constructed filters may bypass internally allowing dirty fuel and water to reach the engine.	Racor uses high quality materials and production processes to ISO/TS16949 to eliminate bypass problems.
Split Or Leaking Seals	Poor quality seals will swell excessively, leak, and may deteriorate within the service period.	Racor uses high quality automotive grade gaskets and seals that are compatible with B20 bio-diesel (i.e. NBR, HNBR, and Viton®).
Dirty Fuel Reaching Engine	Inefficient filters will not protect the engine.	Racor replacement filters will perform as designed for the application.
Water In Fuel Reaching Engine	Very few, if any, copycat filters perform to original equipment specifications.	Racor uses the same media and materials in original equipment and replacement filters.
Cold Conditions	Poor quality pump diaphragms and seals will harden and cause leaking.	Racor uses high quality materials that are rated for operating temperatures of -40° to +255°F (-40° to +124°C).
Cracked Head Casting	Poor quality head castings cannot cope with extreme environmental conditions and vibrations.	Racor products are validated under extreme vibration and climatic conditions.
Contains Banned Substances	Some copy filters contain banned substances in the canister coating and plating.	Racor canisters contain no banned substances and are validated under extreme salt spray and climatic conditions.
Cracked Clear Bowl	Copycat filter bowls are often made from poor quality material that will crack under extreme temperature, chemical exposure, or continuous vibrations.	Racor uses a unique durable clear plastic bowl material with high clarity, excellent UV protection, low and high temperature resistance, is impact resistant, and is impervious to all fuel types.
Filter Accessories	Unauthorized Racor copies do not always offer accessories. If they do, they are likely not tested.	Racor has a wide range of filter accessories that are validated for integrity, EMC compatibility, and safety.

Water Separation Efficiency

The critical performance factor for any fuel filter is the water separation efficiency. The graph below shows the performance level of Racor products versus some competitor copies. Racor water separators out perform all competitors during testing.

Be aware that some of these competitor products fail to remove some particulates from the fuel and put the engine system in danger.



Test Results

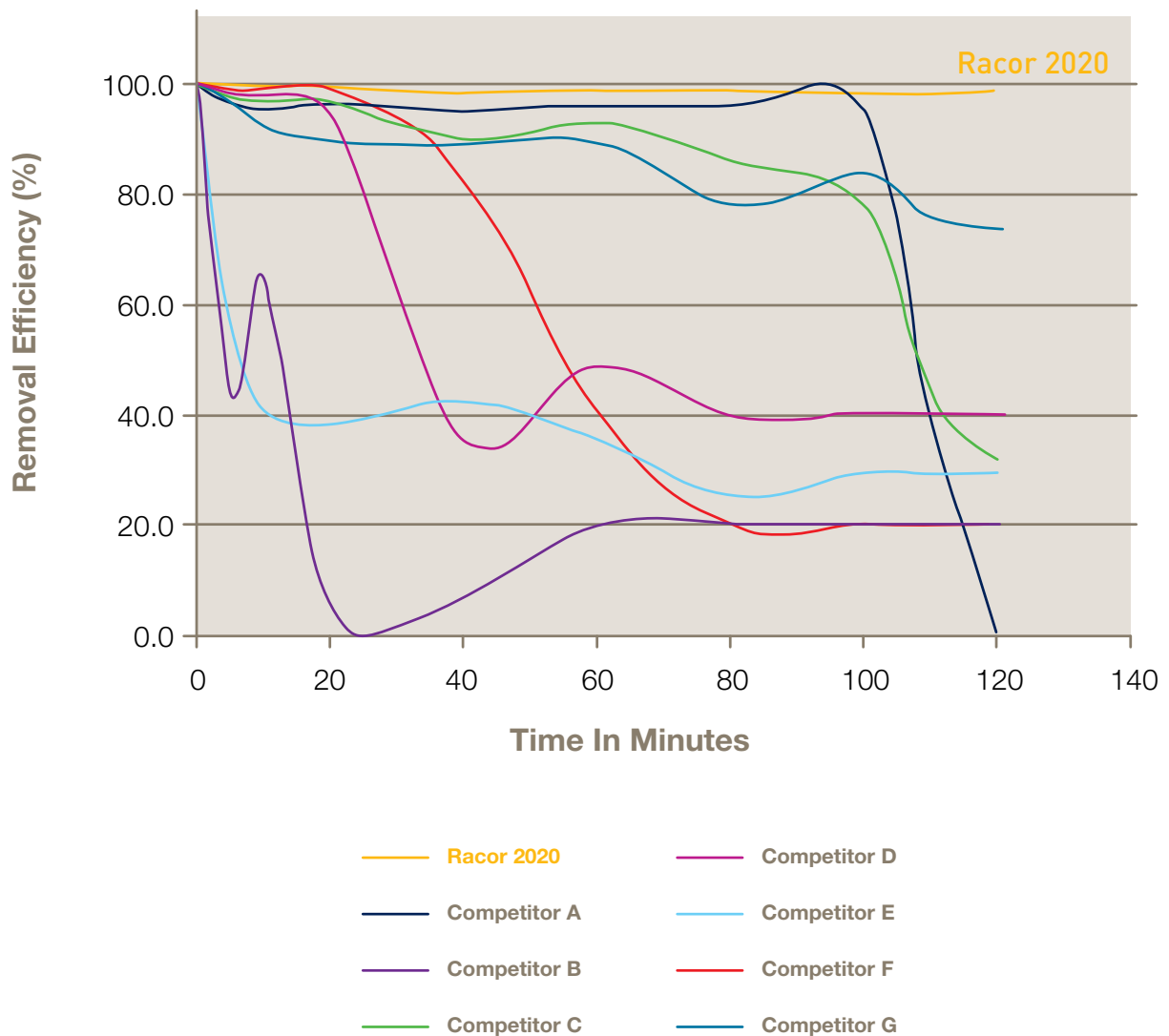

Fuel Filtration



Duplex units offer mariners the peace-of-mind of having a clean filter in reserve. Rough seas can stir up tank sediment which will quickly clog a single fuel filter.

With Racor, a simple turn of a valve puts a clean filter back on-line. Servicing of the clogged filter can then be preformed even with the engine running.

Legendary Diesel Fuel Filtration

When engines demand heavy-duty, high-capacity water separation and fuel filtration, the Turbine Series is the most complete, efficient, and reliable engine protection you can install. Symbolizing Racor's continuing commitment to the science of filtration, the Turbine Series has established its position as the filter/separator often imitated, but never equaled.

Models that include an aluminum bowl or stainless steel shield meet ASTM FS1201, Veritas, Det Norske Veritas, ISO 10088, and USCG accepted. For severe service, all-metal bowls should be specified.

Paired with our famous and genuine Aquabloc® filters, the Racor Turbine Series is still the preferred brand for serious sailors globally.



The Inside Story

1 As fuel enters, it moves past the internal check valve, then through the turbine centrifuge where it flows in a spiraling direction, spinning off large particulates and water droplets. Being heavier than fuel, they fall to the bottom of the bowl.

2 Smaller water droplets bead-up along and on the sides of the internal components and on the surface of the Aquabloc® filter. When large enough, they too fall into the high-capacity bowl to be drained as needed.

3 Besides repelling water asphaltenes, algae, rust, and tiny solids from fuel. Aquabloc® filters are waterproof, so they remain effective longer, that saves you money.

T-handle for easy filter servicing. An optional T-handle restriction gauge kit is available

Genuine Aquabloc® replacement filter.

An internal shut-off valve in the 900 and 1000 series safeguards your engine from inferior will-fit filters.

Rugged, die cast aluminum construction.

Checkball.

Turbine centrifuge.

MA units have clear bowls with a metal shield. MAM bowls are all-metal.

UL-listed drain valve and water sensor probe options are available.

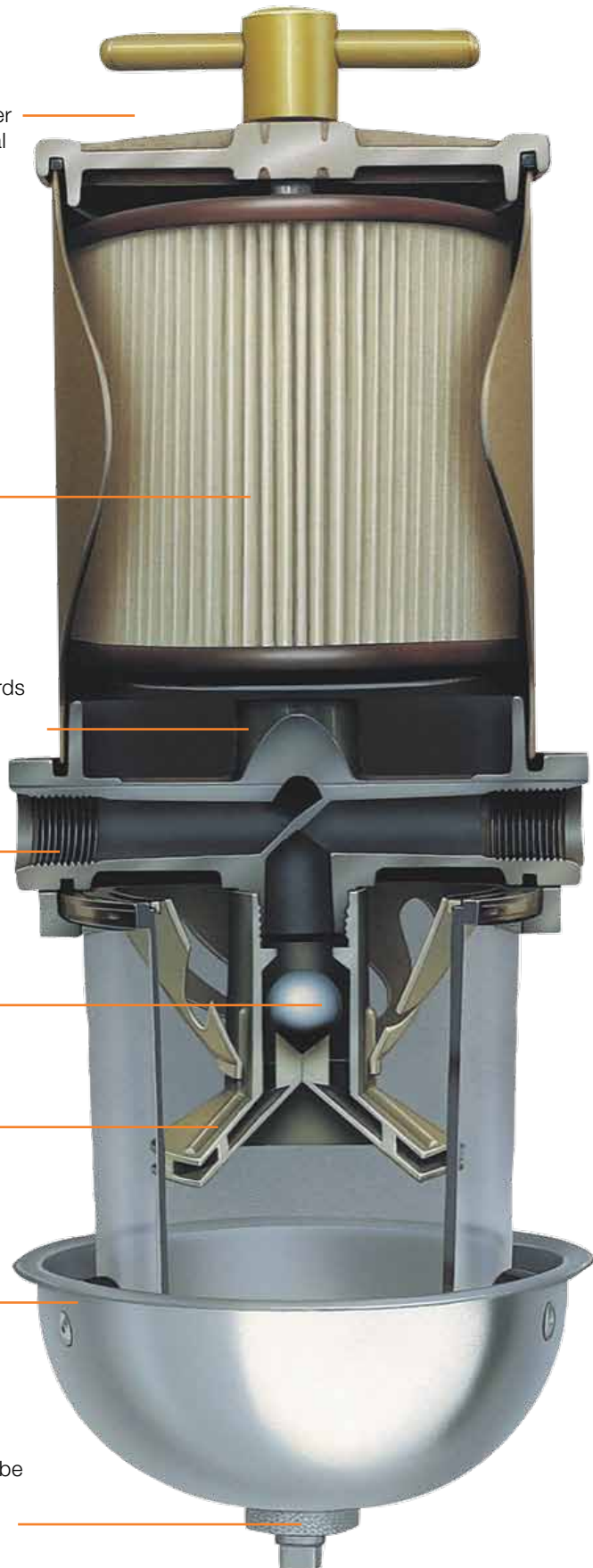

ABS Certification: From November 2010, clear bowls are not accepted on ABS certified vessels. Vessels with clear bowls should change the bowl with a metal bowl kit. (500MA = RK15301-01, 900 and 1000MA = RK11734-01)

Make certain that you replace your Turbine Series assemblies only with Genuine Racor Aquabloc® filters. While many others try to imitate the construction and performance of Aquabloc® filters, only the genuine article delivers the fit and performance specified by engine manufacturers, and guarantees that your Racor filter/water separator will deliver the protection you count on.

For convenience, end-caps are color-coded for easy identification and application.

- Red = 30 micron.
- Blue = 10 micron.
- Brown = 2 micron.

The top cap includes handles for easy servicing and a filter bypass button for emergencies.



Aquabloc® media is a blend of high-grade cellulose compounded with engineered fibers, and a special chemical treatment. Water will not cling to the filter, Aquabloc® repels it.

Aquabloc® Filters

Besides removing asphaltenes, water, gums, and varnishes, Aquabloc® filters out tiny particles of dirt and algae from diesel fuel. Aquabloc® filters have polymer end-caps that will not corrode, ever.

With an Aquabloc® replacement filter, you get a complete kit with all the seals you need. And not just any seals, but specially formulated, Racor-engineered seals.

Always carry extra Racor fuel filters as one tankful of dirty fuel can quickly clog a filter.

Many Racor filters include an emergency bypass.



Order only genuine Aquabloc® replacement filters.

2020	TM	-OR
Select Filter 2010 (500 Series), 2040 (900 Series), or 2020 (1000 Series)	Select a Micron Rating SM = 2, TM = 10, or PM = 30	Must have " -OR " in part number (includes o-rings)

Marine Turbine Series

Ordering and Specification

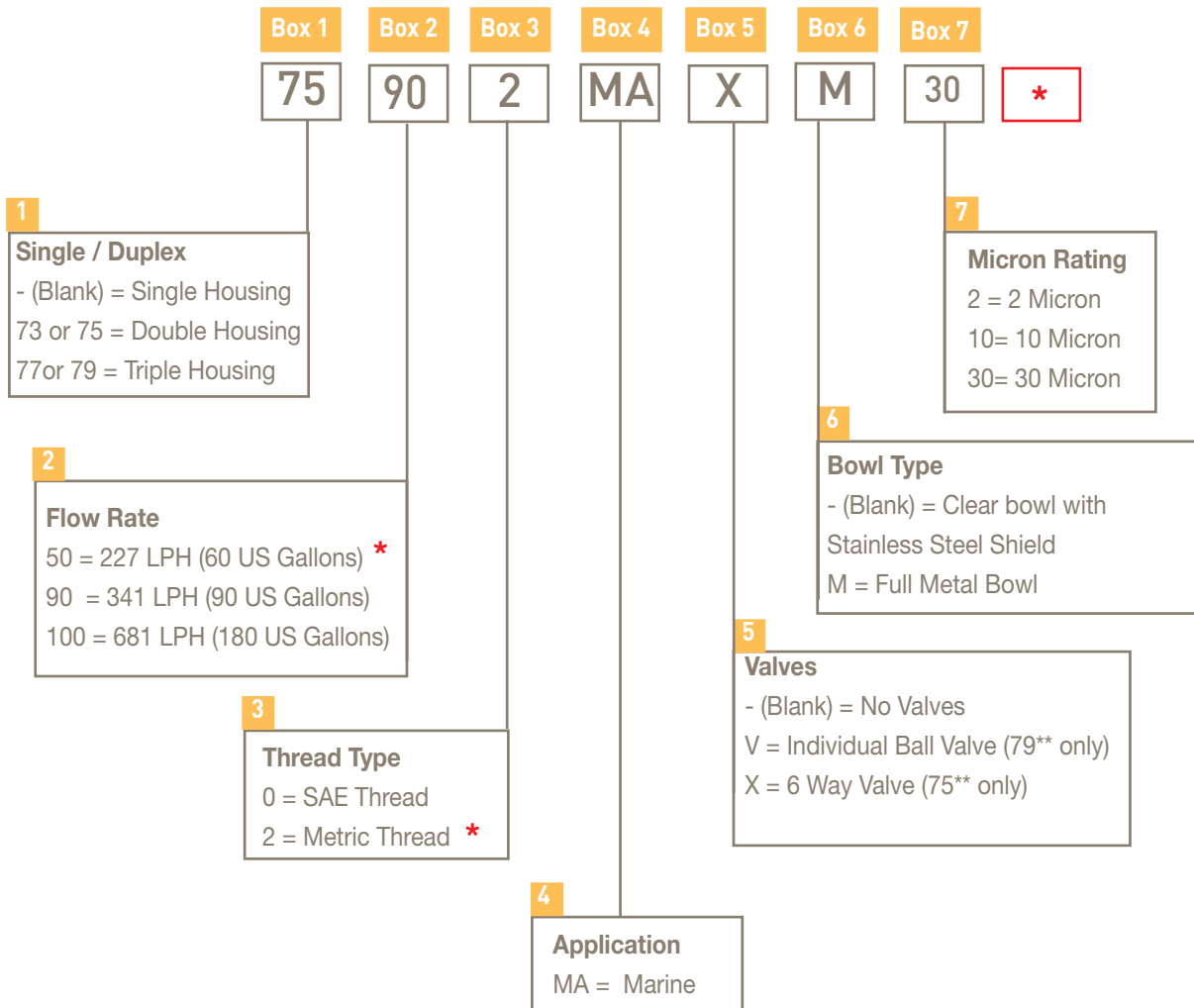

*** Note:**

For 500 Series MA Housings in metric please use suffix "MTC" rather than "502"
 e.g. Use "500MA10MTC" and not "502MA10"



Marine Turbine Series

Ordering and Specification



Model	500MA	900MA	1000MA	75500MAX	75900MAX
Max. Flow Rate (One filter on-line) (Two filters on-line)	227 LPH (60 GPH) N/A	341 LPH (90 GPH) N/A	681 LPH (180 GPH) N/A	227 LPH (60 GPH) 454 LPH (120 GPH)	341 LPH (90 GPH) 681 LPH (180 GPH)
Height	29.2 cm (11.5 in.)	43.2 cm (17.0 in.)	55.9 cm (22 in.)	29.2 cm (11.5 in.)	43.2 cm (17.0 in.)
Width	14.7 cm (5.8 in.)	15.2 cm (6.0 in.)	15.2 cm (6.0 in.)	36.8 cm (14.5 in.)	47.8 cm (18.8 in.)
Depth	12.2 cm (4.8 in.)	17.8 cm (7.0 in.)	17.8 cm (7.0 in.)	24.1 cm (9.5 in.)	27.9 cm (11.0 in.)
Weight (approx.)	1.8 kg (4 lbs)	2.7 kg (6 lbs)	7.7 kg (17 lbs)	7.7 kg (17 lbs)	10.4 kg (23 lbs)
Port Size (500 Series metric = MTC ¹)	16 mm x 1.5 3/4"-16 SAE	22 mm x 1.5 7/8"-14 SAE	22 mm x 1.5 7/8"-14 SAE	N/A 3/4"-16 SAE	N/A 7/8"-14 SAE
Clean Pres. Drop	0.02 bar (0.3 PSI)	0.02 bar (0.3 PSI)	0.03 bar (0.49 PSI)	0.05 bar (0.70 PSI)	0.12 bar (1.7 PSI)
Max. Operating Pressure ²	1.03 bar (15 PSI)	1.03 bar (15 PSI)	1.03 bar (15 PSI)	1.03 bar (15 PSI)	1.03 bar (15 PSI)
Replacement Filter	2010 Series	2040 Series	2020 Series	2010 Series	2040 Series
Overhead Clearance	10.2cm (4.0 in.)	12.7 cm (5.0 in.)	25.4 cm (10.0 in.)	10.2cm (4.0 in.)	12.7 cm (5.0 in.)
Ambient Temperature Range	-40° to +124°C (-40° to +255°F)				
Maximum Fuel Temperature	88°C (190°F)				

Notes: Units are available with full metal bowls, add "M" after MA, i.e. 1000MAM.

¹ 500 Series use (MTC) for metric port threads ² Vacuum installations are recommended.



Model	731000MA	751000MAX	771000MA	791000MAV
Max. Flow Rate (One filter on-line) (Two filters on-line) (Three filters on-line)	N/A 1363 LPH (360 GPH) N/A	681 LPH (180 GPH) 1363 LPH (360 GPH) N/A	N/A N/A 2044 LPH (540 GPH)	681 LPH (180 GPH) 1363 LPH (360 GPH) 2044 LPH (540 GPH)
Height	55.9 cm (22 in.)	55.9 cm (22 in.)	55.9 cm (22 in.)	55.9 cm (22 in.)
Width	41.9 cm (16.5 in.)	45.7 cm (18.0 in.)	45.7 cm (18.0 in.)	54.6 cm (21.5 in.)
Depth	30.5 cm (12.0 in.)	27.9 cm (11.0 in.)	27.9 cm (11.0 in.)	30.0 cm (11.8 in.)
Weight (approx.)	11.8 kg (26 lbs)	13.6 kg (30 lbs)	17.7 kg (39 lbs)	23.6 kg (52 lbs)
Port Size	3/4"-14 NPT	7/8"-14 SAE	1"-11.5 NPT	3/4"-14 NPT
Clean Pres. Drop	0.12 bar (1.7 PSI)	0.26 bar (3.7 PSI)	0.12 bar (1.7 PSI)	0.17 bar (2.5 PSI)
Max. Operating Pressure ³	1.03 bar (15 PSI)	1.03 bar (15 PSI)	1.03 bar (15 PSI)	1.03 bar (15 PSI)
Replacement Filter	2020 Series	2020 Series	2020 Series	2020 Series
Overhead Clearance	25.4 cm (10.0 in.)	25.4 cm (10.0 in.)	25.4 cm (10.0 in.)	25.4 cm (10.0 in.)
Ambient Temperature Range	-40° to +255°F (-40° to +124°C)			
Maximum Fuel Temperature	190°F (88°C)			

Notes: Units are available with metal bowls, add "M" after MA, i.e. 1000MAM. ³ Vacuum installations are recommended.



Electric Primer Pump Kit

Racor's electric primer pump kit can be retrofitted to many of the Racor 900 or 1000 Turbine Series fuel filters/water separators already in service.

The filter pump is an innovative and proprietary system consisting of a 100 micron pre-screen filter, a flow bypass circuit, and an innovative roller cell pump powered by a 12 or 24 vdc Racor brushless motor.

When the switch is activated the fuel is drawn into the pre-screen, then pumped through the housing, refilling the unit with fresh, clean, dry fuel.

When not in use, the filter pump system is bypassed and the Racor fuel filter/water separator functions normally.

The complete primer pump kit includes a wiring harness and controller switch.

Order Part Number:

- **RKP1912** for 12 vdc systems
- **RKP1924** for 24 vdc systems



The unitized assembly is only 3.3 in. (8.4 cm) tall and kit is easily retrofitted to a 900 or 1000 series filter. For Racor duplex or triplex filter systems, only one primer pump is needed.

Note: Do not use in continuous duty applications.

Fuel Polishing Module

Daily buildup of condensation in a diesel fuel system can lead to fuel contamination through bacteria growth. Parker's new FPM installation kits combat the daily accumulation of water in the fuel system, preventing corrosion and other problems. Regular use of a Racor Fuel Polishing Module (FPM) maximizes the effectiveness of a Racor fuel filter/water separator while keeping power consumption to a minimum.

Choose From Two Kits

FPM-051 Kit: Includes a FPM-050 Fuel Polishing Module, a Racor 503MA Turbine Series fuel filter/water separator, a USCG approved fuel hose, and fittings.

OR

FPM-052-A Kit: Includes a FPM-050 Fuel Polishing Module, a Racor 503MA fuel filter/water separator, USCG approved fuel hose, fittings, and a stylish black anodized FPM timer that enables you to program the fuel polishing system to run while unattended (#FPM-PTC-12-A).



Specifications	FPM-050
Filtration Rate	50 gal/day (189 L/day)
Power Requirements	< 2 W (< 3 A-hrs/day)
Internal Pressure Drop	< 0.5 PSI (< 0.03 bar)
Voltage Requirements	10-16 VDC, 12 VDC nominal
Approx Dimensions (Body) (Body with Bracket)	3.87" L x 2.47" W x 2.14" D 3.87" L x 4.48" W x 2.14" D
Inlet/Outlet Ports	3/8" NPTF
Recirculation Port	1/4" NPTF
Weight	< 2 lbs (< 0.9 kg)
Acceptable Fuels	Diesel, Biodiesel, Kerosene

Note: Pump and FPM timer can be purchased separately.

Filter Funnels



Caution for Users: Petroleum products flowing over a plastic surface generate static electricity. Caution should be taken to ensure that the RFF is grounded to reduce static electricity buildup and reduce the chance of explosions or fire. Electrically bond the funnel by using a wire with a metal clip on each end and clamp one to the upper rim of the funnel and the other to the fueling source. For example, the metal gas can or nozzle from the pump.

Fuel Filter Funnel

Racor Filter Funnel (RFF) is a heavy-duty, fast-flow, filter-in-a-funnel that separates damaging free water and contaminants from gasoline, diesel, heating oil, and kerosene.

The RFF family of products is capable of removing free water and solids down to 0.005 inches and allows you to visually inspect the integrity of your fuel supply as you refuel.

The RFF family is manufactured using industrial-grade black electro-conductive polypropylene. Carbon powder is injected into the plastic so that the RFF will conduct static electricity. The grounding capability of the RFF is an important safety feature. Always use proper fuel handling procedures and follow local, state, and federal regulations.

800 Series (804,806,812)

800 Series fuel filter/water separators offer large diesel engine operators ease of maintenance and continuous engine operation. The 800 Series is available in single, duplex or triplex configurations.

The compact 804MA Series diesel fuel filter/water separator is made of 100% steel construction to meet applicable marine classification society requirements for marine fuel filters on classed and inspected vessels.

The 804MA series is available in single, dual valved and triple valved configurations and handle fuel flow rates of 240, 480 and 720 gallons per hour, respectively; utilizing the standard Racor 2020 Series filter cartridges.

Genuine Racor 2020 filter cartridges feature our proprietary Aquabloc® media and are readily available globally. The 2020 Series cartridges are available in 2, 10, and 30 micron filtration ratings.



804 Series



Specifications	804MA	75804MA	79804MA
Maximum Flow Rate	240 GPH (908 LPH)	480 GPH (1817LPH)	1080 GPH (4088 LPH)
Fuel Ports	3/4" NPT	3/4" NPT	3/4" NPT
Max Working Pressure	10 PSI (0.69 bar)	10 PSI (0.69 bar)	10 PSI (0.69 bar)
Clean Pressure Drop	0.48 PSI (0.03 bar)	0.48 PSI (0.03 bar)	0.48 PSI (0.03 bar)
Replacement Filter	2020 Series	2020 Series x 2	2020 Series x 3
Height	19.8 in. (50.3 cm)	19.8 in. (50.3 cm)	19.8 in. (50.3 cm)
Width	6.57 in. (16.7 cm)	17.5in (44.5cm)	25.5 in. (69.8 cm)
Depth	8.73 in. (22.2 cm)	15.5 in (39.2 cm)	15.5 in (39.2 cm)
Weight (approx.)	25 lbs (11.3 kg)	60lbs (27.2 kg)	90 lbs (40.8 kg)

2020	TM	-OR
2020 (1000 Series)	Micron Rating SM = 2, TM = 10, or PM = 30	Must have "-OR" in part number (includes o-rings)

* Note all flow rates and dimensions and weights for the 804MA series are approximations and are subject to change.

806 / 812 Series

812MA Series assemblies utilize a unique two-stage filtration system which includes a water coalescing filter and a final, 40 micron, depth filter (part number for filter kit is RK22610).



Specifications	806MA	75806MA	79806MA	812MA	75812MA	79812MA
Maximum Flow Rate	360 GPH (1363 LPH)	720 GPH (2725 LPH)	1080 GPH (4088 LPH)	720 GPH (2725 LPH)	1440 GPH (5451 LPH)	2160 GPH (8176 LPH)
Fuel Ports	1" NPT	1" NPT	1" NPT	1" NPT	1" NPT	1 1/4" NPT
Max Working Pressure	2.1 bar	2.1 bar	2.1 bar	2.1 bar	2.1 bar	2.1 bar
Clean Pressure Drop	0.1 bar	0.2 bar	0.4 bar	0.2 bar	0.4 bar	0.35 bar
Replacement Filter	RK 22788*	(2) RK 22788*	(3) RK 22788*	RK 22610**	(2) RK 22610**	(3) RK 22610**
Height	57.9 cm	57.9 cm	57.9 cm	84.3 cm	84.3 cm	84.3 cm
Width	16.8 cm	55.4 cm	84.6 cm	16.8 cm	55.4 cm	84.6 cm
Depth	22.6 cm	40.6 cm	40.6 cm	22.6 cm	40.6 cm	40.6 cm
Weight (approx.)	11.3 kg	23.6 kg	35.8 kg	16.3 kg	40.4 kg	60.3 kg
Sump Capacity	3.8 l	7.6 l	11.0 l	3.8 l	7.6 l	11.0 l
Temperature	Ambient Temp range: -40° to +255°F (-40° to +124°C) Max fuel Temp: 190°F (88°C)					

* RK 22788 – Replacement filter kit (contains one each of 4021 and 4022 filter and a lid gasket; 75806MA requires 2 kits; 79806MA requires 3 kits).

** RK 22610 – Replacement filter kit (contains one each of 8021 and 8022 filter and a lid gasket; 75812MA requires 2 kits; 79812MA requires 3 kits).

804MA Features

- 100% Steel Construction By ASME Certified Welders
- Stainless Steel T-handle On Steel Lid
- Steel/High Pressure Glass Water Sight-Gauge
- Steel Contaminant Sump With Steel Drain Plug
- Marine-Grade White Exterior Coating
- Durable Steel Mounting Brackets

Compact and Versatile Systems for Main Propulsion and Genset Applications

Cost-Effective

Cost-effective designs for on-engine or remote mounting. Complete assemblies available in all-metal bowls.

High-Capacity

Hand-operated fuel priming pumps are integral to many Racor diesel spin-on series models, a feature that allows for removal of unwanted air from the filter and engine fuel system.

Environmentally Friendly

Metal bowls are reusable, impact-resistant, and virtually indestructible. When it's time for service, only the filter is replaced—the bowl and drain plug are reused. The long life-cycle of Racor bowls saves you money and reduces the environmental impact through disposal of less material.

Note: Use metal bowl versions for all marine engine room applications.

Easy Upgrades

Water-in-fuel (WIF) sensors are available to alert operators to drain accumulated water from the bowl.

Corrosion-Resistant Construction

Advanced technology means bowls will not deteriorate from water collection, alcohol-blended fuels, exposure to harsh additives, salt spray, or UV light.

Safety First

Racor's UL-listed filters meet ABYC, ASTM, ISO, and many other global standards for filters used in marine engine rooms.

Diesel Spin-On Series

Powerful primer pumps integrated into mounting heads.

Die cast aluminum heads with multiple ports make installation as easy as adding options.



The best gaskets and o-rings available for consistent, sure seals.

Aquabloc® media is corrugated, allowing greater surface area exposure for fuel filtration/water separation, and an increased dirt-holding capacity.

Bowls are virtually indestructible. They won't discolor from exposure to alcohol, additives, or UV light. A die cast aluminum bowl with epoxy powder paint and drain plug meet CFR33 regulation and other marine standards.

Brass plug with tapered thread meets ABYC standards.

Water sensor options are available for most models (RK30880E shown, UL-Listed).



Diesel Spin-on Filters



Racor Aquabloc® Spin-on Fuel Filters Are Available in Color Coded 2, 10, or 30 Micron Ratings.

P = 30 micron.

T = 10 micron.

S = 2 micron.

Aquabloc® Spin-on Fuel Filters

Besides removing asphaltenes, water, gums, and varnishes, Aquabloc® filters out tiny particles of dirt and algae from diesel fuel.

With an Aquabloc® replacement filter, you get a complete kit with all the seals you need. And not just any seals, but specially-formulated, Racor-engineered seals.

Always carry extra Racor fuel filters as one tankful of dirty fuel can quickly clog a filter.

Please specify carefully – there are important differences among Spin-On Series features which effect performance and application.



Specifications	215RMAM	230RMAM	245RMAM	445MAM10	460MAM10	490MAM10	4120MAM10
Maximum Flow Rate	57 LPH (15 GPH)	114 LPH (30 GPH)	170 LPH (45 GPH)	170 LPH (45 GPH)	227 LPH (60 GPH)	341 LPH (90 GPH)	454 LPH (120 GPH)
Maximum PSI ¹	2.1 bar (30 PSI)	2.1 bar (30 PSI)	2.1 bar (30 PSI)	1.0 bar (15 PSI)	1.0 bar (15 PSI)	1.0 bar (15 PSI)	1.0 bar (15 PSI)
Clean Pressure Drop	0.01 bar (0.12 PSI)	0.02 bar (0.3 PSI)	0.04 bar (0.6 PSI)	0.01 bar (0.12 PSI)	0.02 bar (0.3 PSI)	0.03 bar (0.4 PSI)	0.03 bar (0.4 PSI)
Port Size	1/4"-18 NPTF	1/4"-18 NPTF	1/4"-18 NPTF	3/8" NPTF	3/8" NPTF	3/8" NPTF	3/4" SAE
Primer Pump	Yes	Yes	Yes	Yes	Yes	Yes	Yes
Replacement Filter	R15TUL	R20TUL	R25TUL	S3204TUL	S3211TUL	S3201TUL	S3201TUL
Number of Ports	3	3	3	4	4	4	4
Water Sensor Option	RK30880E						
Height	19.6 cm (7.7 in.)	22.9 cm (9.0 in.)	26.7 cm (10.5 in.)	23.9 cm (9.4 in.)	27.4 cm (10.8 in.)	32.5 cm (12.8 in.)	32.5 cm (12.8 in.)
Width	9.9 cm (3.9 in.)	9.9 cm (3.9 in.)	10.2 cm (4.0 in.)	11.4 cm (4.5 in.)	11.4 cm (4.5 in.)	11.4 cm (4.5 in.)	11.4 cm (4.5 in.)
Depth	10.2 cm (4.0 in.)	10.2 cm (4.0 in.)	10.2 cm (4.0 in.)	12.2 cm (4.8 in.)	12.2 cm (4.8 in.)	12.2 cm (4.8 in.)	12.2 cm (4.8 in.)
Weight (approx.)	0.5 kg (1.2 lbs)	0.9 kg (2.0 lbs)	1.0 kg (2.2 lbs)	10.3kg (2.9 lbs)	1.4 kg (3.1 lbs)	1.5 kg (3.3 lbs)	1.5 kg (3.3 lbs)
Ambient Temp Range	-40° to +124°C (-40° to +255°F)						
Maximum Fuel Temp	88°C (190°F)						

¹ Pressure Installations are applicable up to the maximum PSI shown, vacuum installations are recommended.

Marine Small Craft

Ordering and Specification

This MSC Spin-On filter series based on the successful 400 and 600 Series filters and now has a metal bowl Fire Tested to BS EN 7840:2004, fulfilling the requirements set out in ISO 10088:2001 small craft directive.

This filter is particularly good for use in applications where space is at a premium, or where there is a desire to mount the fuel filter water separator directly onto an engine.

The filters are available in 3 sizes: 60GPH (227LPH), 90GPH (341LPH) and 160GPH (600LPH), and they can be specified with either the 400 series aluminium head incorporating a manual primer pump, or the 600 series head without primer pump.

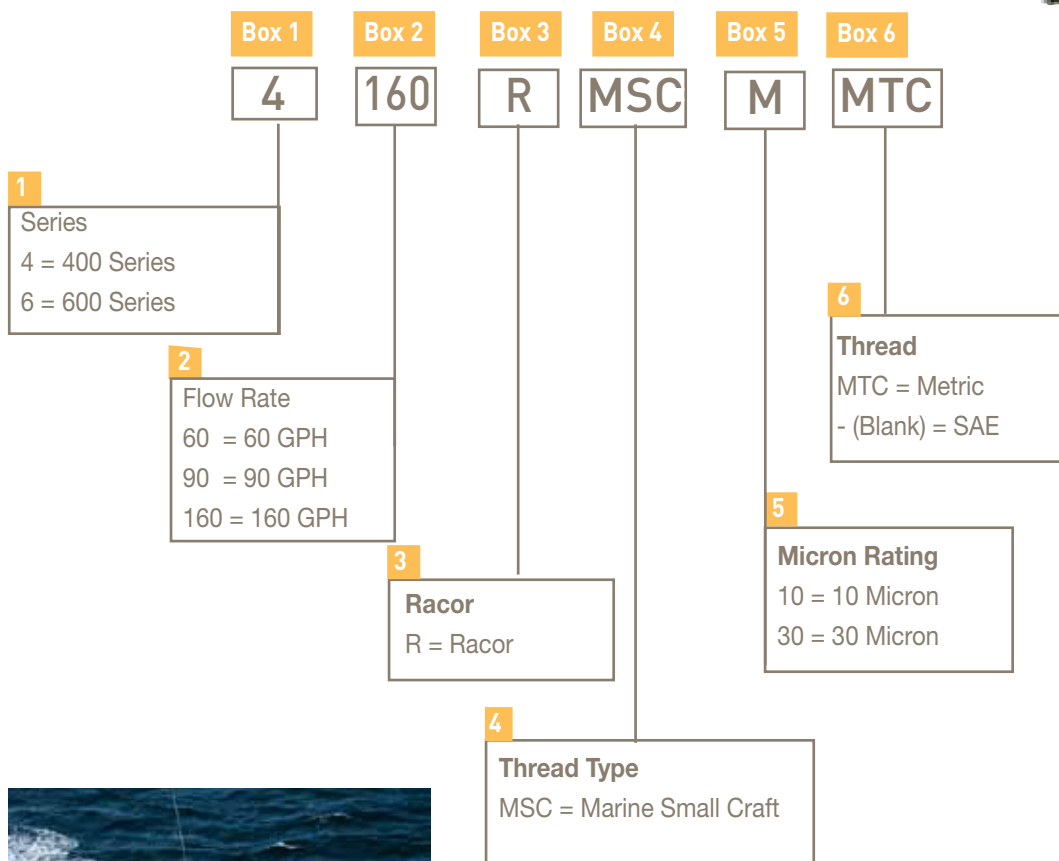

Model	Replacement Filter Canister
460RMSC10MTC	R60T-D-MAX
490RMSC10MTC	R90T-D-MAX
4160RMSC10MTC	R160T
660RMSC10MTC	R60T-D-MAX
690RMSC10MTC	R90T-D-MAX
6160RMSC10MTC	R160T

High Flow Spin-On

At the Pump

Start protecting your engine investment right at the pump. Racor's Fuel Dispensing Filters are essential for stationary and overhead tanks and mobile service vehicles. With their easy-to-install heads, they remove virtually 100% of the contaminants from diesel fuel.

Racor FDW filters feature a super-absorbent, chemically-treated media that absorbs 25 times its weight in water, "locking it in" as a barrier against free and emulsified water. There is no bypass valve which ensures that your engine is completely protected. As the media swells, it significantly reduces fuel flow rate, signaling a need to replace the filter.

Racor offers filter protection down to 25 micron (nominal). Flow rates range from 15 to 100 GPM (57 to 379 LPM). Filter service is clean and easy, there's no cartridge to replace, just spin-on a new Racor filter.

Filter Heads



Part Number	PFHH07500	PFFDH12500	23179001**
Port Size	3/4" NPT	1 1/4" NPT	1 1/2" NPT
Filter	PFFDW3525	PFFDW51125	PFFDW51125 (two filters required)
Center Thread	1"-12 UNF	1 1/2"-16 UNF	1 1/2"-16 UNF
Max. Flow Rate	15 GPM (57 LPM)	50 GPM (189 LPM)	100 GPM (379 LPM)

Fuel dispensing filters can be used with diesel fuel or gasoline. **23179001 dual head. Call Parker Hydraulic Filter Division to order (419-644-4311).

Water Removing Filters



Part Number	PFFDW3525	PFFDW51125
Micron Rating	25	25
Filter Size	3.7 D x 5.5 L	5.0 D x 11.0 L
Center Thread	1"-12 UNF	1 1/2"-16 UNF

Maximum operating pressure of fuel dispensing filter heads and water removing filters is 100 PSI (6.9 bar). 10 micron filters available through special order.

3150R and 3250R High Flow Filters

High flow applications need not suffer with high maintenance... and Racor offers a range of ultra-high capacity, highly efficient fuel filter/water separators that also deliver spin-on convenience.

As you'd expect, Aquabloc® media is standard and all units provide flexibility in options to customize and meet specific operating conditions.

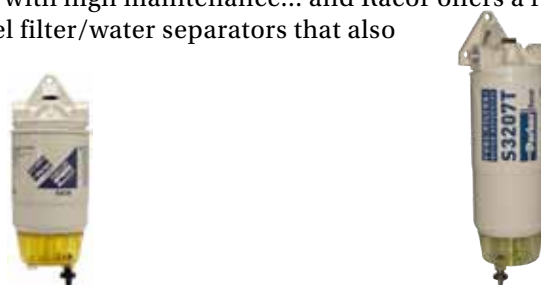

Specifications

Part Number	3150R	3250R
Maximum Flow Rate	150 GPH (568 LPH)	250 GPH (946 LPH)
Maximum Working Pressure	7 PSI (0.48 bar)	7 PSI (0.48 bar)
Filter	S3238	S3207T
Port Size	7/8"-14 SAE	7/8"-14 SAE
Height	13.6 in. (34.5 cm)	17.3 in. (43.9 cm)
Width	5.0 in. (12.7 cm)	5.0 in. (12.7 cm)
Depth	5.5 in. (14.0 cm)	5.5 in. (14.0 cm)
Weight (approx.)	3.6 lbs (1.6 kg)	4.6 lbs (2.1 kg)
Clean Pressure Drop	0.7 PSI (0.05 bar)	1.0 PSI (0.07 bar)
Water Capacity (in bowl)	2.8 oz (82.8 ml)	2.8 oz (82.8 ml)
Ambient Temp Range	-40° to +255°F (-40° to +124°C)	
Maximum Fuel Temperature	190°F (88°C)	

Fuel Conditioning Module

Ordering and Specification



Durable, 12 vdc roller-cell electric fuel pump offers the benefit of an electric, on-demand, priming pump.

A fuel filter/water separator and primer pump in one unit.

High-performance Aquabloc® cartridge-style filter media is environmentally friendly and incinerable.

Important Note: ABYC standards allow for installation outside of the engine room only.

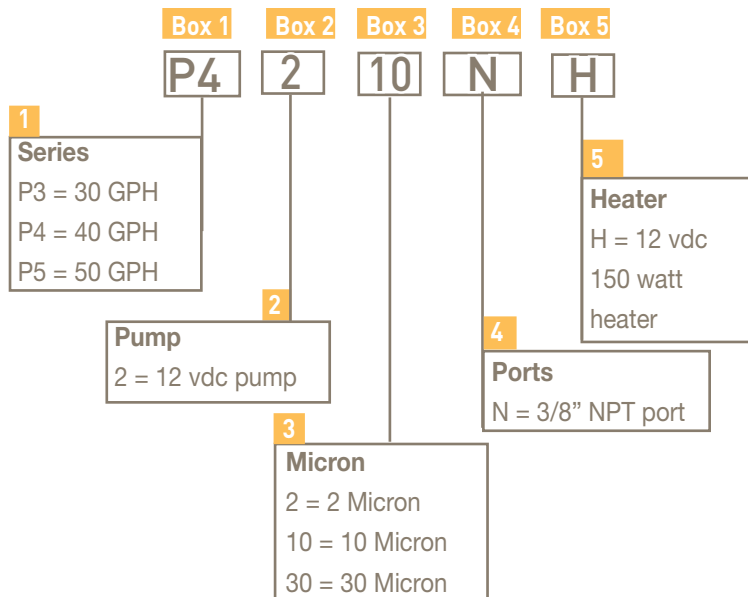

The P Series Diesel Fuel Conditioning Module (for vacuum side applications only) was developed for application in any diesel engine fuel injection system. P Series assemblies are available in three sizes and all feature 3/8" NPT fuel ports. This innovative and modular fuel filter/water separator incorporates low-pressure fuel system components into a single package. It supplies clean, dry fuel to the fuel system and serves as a repriming system.

Specifications	P3	P4	P5
Maximum Flow Rate	114 LPH (30 GPH)	151 LPH (40 GPH)	189 LPH (50 GPH)
Clean Pressure Drop	0.4 PSI (0.03 bar)	0.5 PSI (0.03 bar)	0.8 PSI (0.06 bar)
Max. Pump Output (at 14.4 volts)	40 GPH (151 LPH)	40 GPH (151 LPH)	40 GPH (151 LPH)
Standard Fuel Port Size (SAE J476)	3/8"-18 NPT	3/8"-18 NPT	3/8"-18 NPT
Total Number of Ports Available	2	2	2
Fuel Inlets	1	1	1
Fuel Outlets	1	1	1
Replacement Filter			
2 micron	R58060-02	R58095-2	R58039-2
10 micron	R58060-10	R58095-10	R58039-10
30 micron	R58060-30	R58095-30	R58039-30
Minimum Service Clearance	6.4 cm (2.5 in.)	6.4 cm (2.5 in.)	6.4 cm (2.5 in.)
Height	19.6 cm (7.7 in.)	22.9 cm (9.0 in.)	29.2 cm (11.5 in.)
Depth	13.2 cm (5.2 in.)	13.2 cm (5.2 in.)	13.2 cm (5.2 in.)
Width	12.2 cm (4.8 in.)	12.2 cm (4.8 in.)	12.2 cm (4.8 in.)
Weight (dry - approx.)	3.4 lbs (1.5 kg)	3.8 lbs (1.7 kg)	4.2 lbs (1.9 kg)
Maximum Pump Outlet Pressure	10 PSI (0.7 bar)	10 PSI (0.7 bar)	10 PSI (0.7 bar)
Features			
Water Sensor	Standard	Standard	Standard
Heater ¹	Standard	Standard	Standard
Pressure Regulator (10 PSI)	Standard	Standard	Standard
Ambient Temp Range	-40° to +255°F (-40° to +124°C)		
Maximum Fuel Temperature	190°F (88°C)		

Vacuum installations are recommended. ¹ Not for use with gasoline applications.



Every Time You Squeeze The Trigger, You Threaten Your Engine's Life.

No matter how carefully gasoline is handled or stored, dirt, rust, gums, algae, and water are going to find their way in, and just a few drops can leave you dead in the water. Racor gasoline fuel filter/water separators with Aquabloc® media remove virtually 100% of damaging water and solids, allowing engines to run with more power and greater efficiency. Install a Racor mounting head or spin directly onto your existing filter head to protect your engine and improve its performance. Spin on a Racor fuel filter/water separator, for the life of your engine.

Marine Gasoline Series

The Most Complete Protection on the Water

Being on the water is fun, having water in your fuel is not. And more than ever today's high-performance gasoline inboard and outboard engines require clean, dry fuel. Racor filters offer the improved features and peace-of-mind that come with our quality fuel filter/water separators.



- Clear contaminant collection bowl with drain valve for outboards only
- 10 micron Aquabloc® media is standard
- High capacity and long life
- Rated 98% efficient at 10 micron per SAE test procedures
- Corrosion-resistant construction.
- Metal bowl units for inboard powered boats meet 33 CFR and USCG regulations
- Meets ABYC standard for gasoline powered vessels
- New 2 micron option



Specifications	120R-RAC-01	120R-RAC-02	320R-RAC-01	320R-RAC-02	490R-RAC-01	660R-RAC-01	660R-RAC-02	3120R-RAC-32
Max. Flow Rate	114 LPH	114 LPH	227 LPH	227 LPH	341 LPH	341 LPH	341 LPH	454 LPH
Filter (10 micron) (2 micron)	S3240 N/A	S3240TUL N/A	S3227 S3228SUL	S3228TUL S3228SUL	S3227 S3228SUL	S3232 N/A	S3232TUL N/A	S3232TUL N/A
Center Threads	M18 x 1.5	M18 x 1.5	1"-14	1"-14	1"-14	1"-14	1"-14	1"-14
Port Size	1/4"-18 NPTF	1/4"-18 NPTF	1/4"-18 NPTF	1/4"-18 NPTF	3/8"-18 NPTF	3/8"-18 NPTF	3/8"-18 NPTF	1/2"-14 NPTF
Height	16.5 cm	15.2 cm	23.9 cm	22.9 cm	25.1 c)	27.9 cm	26.7 cm	26.4 cm
Width	8.1 cm	8.1 cm	10.2 cm	10.2 cm	11.4 cm	10.7 cm	10.7 cm	10.2 cm
Depth	8.1 cm	8.1 cm	10.2 cm	10.2 cm	12.2 cm	11.4 cm	11.4 cm	52.7 cm
Weight (approx.)	0.5 kg	0.5 kg	0.9 kg	0.9 kg	1.2 kg	1.4 kg	1.4 kg	0.9 kg
Clean Pressure Drop	0.01 bar	0.01 bar	0.04 bar	0.04 bar	0.07 bar	0.04 bar	0.04 bar	0.01 bar
Max. Working Pressure¹	0.5 bar	0.5 bar	0.5 bar	0.5 bar	0.5 bar	0.5 bar	0.5 bar	0.5 bar
Service Clearance (under bowl)	2.5 cm	2.5 cm	2.5 cm	2.5 cm	2.5 cm	2.5 cm	2.5 cm	2.5 cm
Ambient Temp Range	-40° to +255°F (-40° to +124°C)							
Max. Fuel Temperature	190°F (88°C)							

¹ Pressure installations are acceptable up to the maximum PSI shown. Racor filter/separators will not separate oil from gasoline in blended fuel mixtures.

Upgrade Your Gasoline Filter

With These Convenient Spin-On Filters

Now, owners of inboard or outboard engines can get smoother operation and longer life—all in one easy spin, onto their existing engine filter heads. There's a choice of rugged, reusable clear bowls with self venting drains (for outboard applications), or a metal bowl with drain plug (for inboard applications). Metal bowls are UL Listed and USCG accepted.



For inboards or outboards:
B32020MAM
B32021MAM
PFF5510

PFF5510	Replaces Mercury, Mercruiser, Yamaha, Suzuki, Honda, and Tohatsu. 10 micron.
B32020MAM	Replaces quicksilver. Also fits: SMI, Sierra, Aquapower, and other filter heads (comes with a metal bowl—shown above). 10 micron.
S3220TUL ¹	Replacement filter for B32020MAM. 10 micron.
B32021MAM	Replaces OMC. UL Recognized (comes with a metal bowl). 10 micron.
S3221TUL	Replacement filter for B32021MAM. 10 micron.

¹ Optional 2 micron filter (S3220SUL).



For outboards only:
B32013
B32014



B32013	Replaces Quicksilver, Yamaha, Suzuki, SMI, Volvo Penta, Sierra, AquaPower, and other filter heads (comes with a clear bowl—shown above). 10 micron.
S3213	Replacement filter for B32013. 10 micron.
B32014	Replaces OMC (comes with a clear bowl). 10 micron.
S3214	Replacement filter for B32014. 10 micron.

Compact Gasoline Filters for Smaller Boats and Personal Watercraft



Specifications	025-RAC-01	025-RAC-02	110A
Max. Flow Rate	25 GPH (95 LPH)	25 GPH (95 LPH)	35 GPH (132 LPH)
Media	250 micron (cleanable plastic screen)	10 micron (Aquabloc® filter)	10 micron (Aquabloc® filter)
Port Size	1/4"-18 NPTF	1/4"-18 NPTF	1/4"-18 NPTF
Dimensions	H 4.3" x D 2.1"	H 4.3" x D 2.1"	H 6" x D 3.3" x W 3.2"



Gasoline Filters

This Par Fit™ marine fuel filter/water separator fits most inboard, outboard, two and four-cycle gasoline engine applications. The PFF5510 has specially treated Aquabloc® 10 micron rated media, guaranteed to outperform standard gasoline filters.

The Racor PFF5510 gasoline fuel filter/water separator replaces standard filters in the most popular marine gasoline engine applications. Applications include Mercury, Mercruiser, Yamaha, Suzuki, Honda, Tohatsu, and other popular mounting heads. Dimensions are 3.6 in. (9.1 cm) diameter x 4.25 in. (10.8 cm) tall.

Features and Benefits

- High contaminant capacity and 96% @ 10 micron particle removal efficiency makes this filter suitable for all low or high-pressure injection systems.
- 99% efficient water removing filter media.
- Performance exceeds OEM specifications.
- 11/16-16 center threads for the most popular applications.

Fixed Based Operation

FBO and Duplex FBO Series

The slotted locking ring collar attaches the filter housing to the aluminum die cast filter head with four bolts. Metal hand knobs are provided for ease of maintenance.

Powder coated components capable of 150 PSI @ 240°F max design pressure.

Steel filter bowl assembly, a manual vent valve, and a manual drain valve help provide ease of service—especially significant given the FBO assembly’s wide range of installations, including aviation fuel trucks, aviation fueling cabinets, diesel fuel dispensing systems, marine fuel docks, and fuel systems on large diesel engines. 1 1/2" NPT inlet and outlet.



Racor’s FBO-10-MA and FBO-14-MA filter assemblies are designed to meet tough hydrocarbon refueling

conditions and provide for ease of filter change-outs. The FBO assemblies can handle flow rates from 18 to 53 GPM

(68 to 201 LPM) depending on filter specified and fuel being filtered.



Specifications	FBO-10-MA	FBO-14-MA
Fuel Ports	1 1/2" NPT	1 1/2" NPT
Max. Flow Rate	see chart below	
Max. Working pressure	150 PSI @ 240°F (10.3 bar @ 115°C)	
Clean Pressure Drop	1 PSI (0.07 bar)	1 PSI (0.07 bar)
Height	18.8 in. (47.8 cm)	22.6 in. (57.4 cm)
Width	8.6 in. (21.8 cm)	8.6 in. (21.8 cm)
Depth	8.6 in. (21.8 cm)	8.6 in. (21.8 cm)
Weight (approx.)	13 lbs (5.9 kg)	16 lbs (7.3 kg)
Service Clearance	12.0 in. (30.5 cm)	16.0 in. (40.6 cm)
Ambient Temp Range	-40° to +255°F (-40° to +124°C)	
Max Fuel Temperature	190°F (88°C)	



The DFBO duplex filter brings Racor® FBO filters to engine room environment. The new duplex design ensures that fuel is efficiently filtered all the time. The cast iron head and steel bowls mean that it can be used in Marine applications.

Change-over valve with open center position. Locking device for both end positions and center position. Manual vent valves and drain valves.

The DFBO comes with two bowl lengths allowing diesel flows up to 90 l/min. Depending on the elements inside the unit can be used as a prefilter, a water separator/particle filter or a water absorptive filter. Easy service, no special tools are required.

DFBO Ordering Matrix

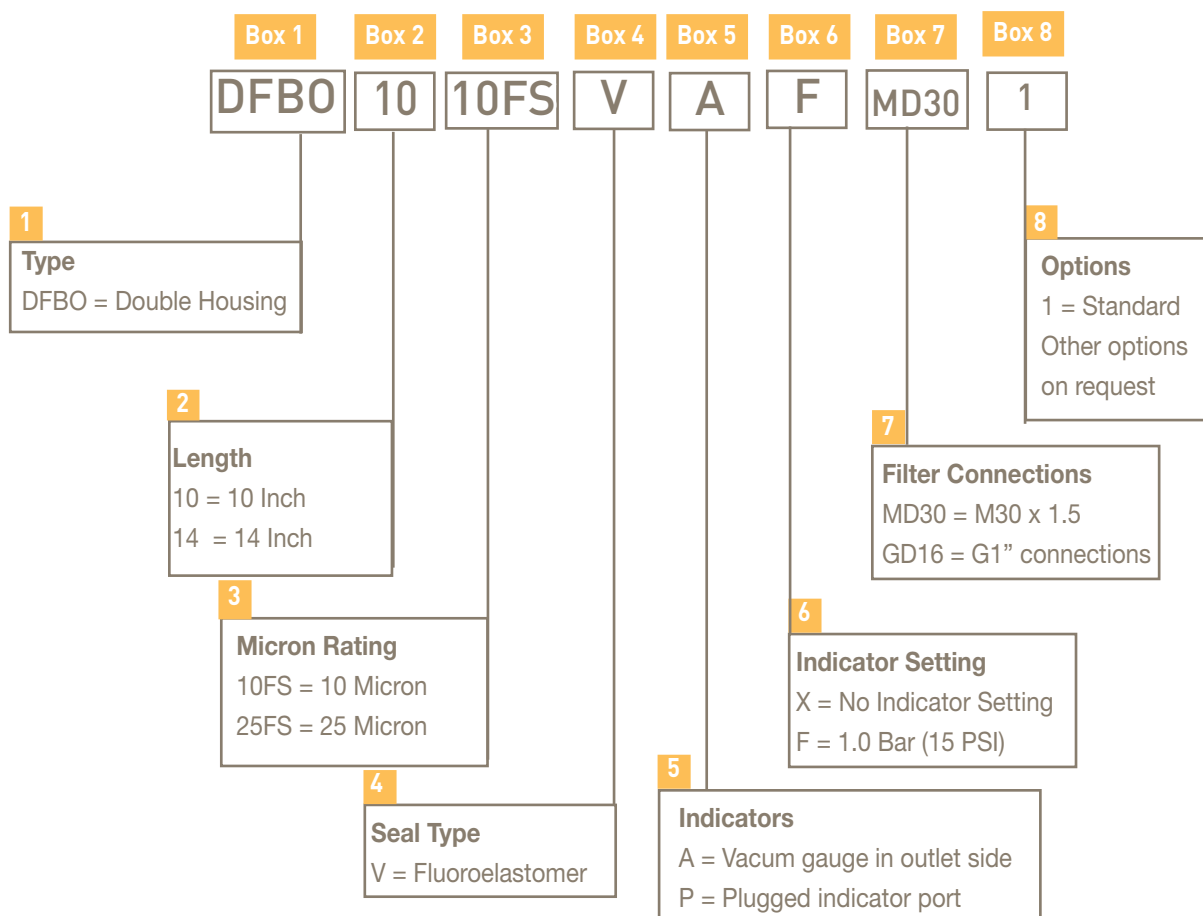

FBO (DFBO) Replacement Filter Element Options

Water Separator

Water separator filters remove water and contaminants from hydrocarbon fuel streams and are the most popular filters.

Silicone Treated

Silicone treated fuel filters remove particle contaminants down to one micron. Silicone filters can be used upstream, before a fuel filter/water separator, to extend filter life.

Water Absorber

Water absorber filters absorb water and filter out contaminants from diesel fuel and other hydrocarbon streams.

FBO	Micron Rating	Water Separator	Silicone Treated (pre-filter)	Water Absorber
FBO-10 (6 X 10 Filter)	1	FBO 60327 FBO 60360 ²	FBO 60330	FBO 60333
	5	FBO 60328	FBO 60331	FBO 60334
	10	FBO 60353	FBO 60354	FBO 60355
	25	FBO 60329	FBO 60332	FBO 60335
FBO-14 ¹ (6 X 14 Filter)	1	FBO 60336 FBO 60361 ²	FBO 60339	FBO 60342
	5	FBO 60337	FBO 60340	FBO 60343
	10	FBO 60356	FBO 60357	FBO 60358
	25	FBO 60338	FBO 60341	FBO 60344

¹ 72951 Monitor adapter plate enables the FBO-14 to take five RMO-210-4 monitor filters.

² API/EI 1583 5th Edition filters are certified for jet fuel applications.

FBO Fuel Filter Trolley

Cleaner fuel means lower costs and less engine wear



The Racor FBO Filter Trolley is a new lightweight mobile unit ideal for on-site cleaning of fuel tanks, drums and bowsers. It incorporates state-of-the-art Racor fuel filter technology which removes potentially damaging contamination from your diesel fuel. Available with a range of filters from 1 to 25 micron it removes particles and virtually 100% water quickly and efficiently (flow rate of over 50 litres per minute).

Key Benefits

- Excellent portability, delivering fast on-site fuel polishing
- Protects engines from failure and unscheduled shutdowns due to contaminated fuel
- Removes need for expensive additional on-engine filtering
- Eliminates cost of replacement fuel
- Safe, stand alone operation due to automatic shut down and in built alarm

Ordering Matrix

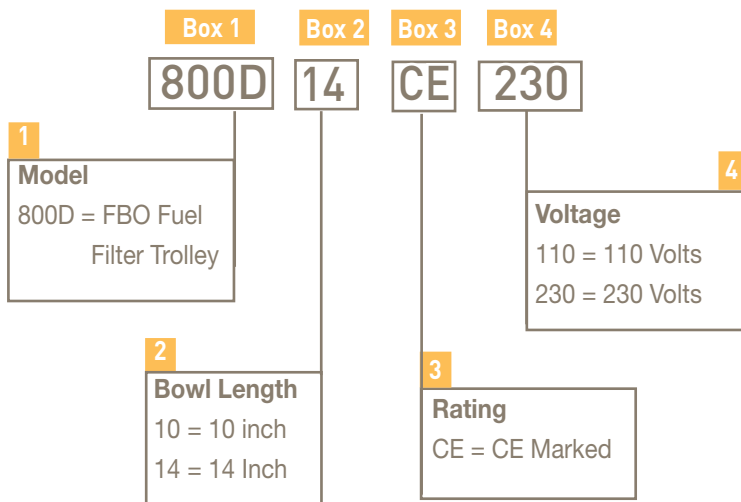

HiFlo Fuel Filtration

The Ultimate In High-Capacity Filtration

For over 35 years, Racor has been recognized as the leader in filtration and separation technology. Our engineering team takes specific application prerequisites, and by utilizing the latest computer-assisted design tools, quickly develops the necessary components to manufacture filter vessels that meet industry and customer-specific requirements. Our successful experience in global applications is the result of a continuous improvement process and real-world evaluations of product performance.



These Filter/Water Separator Vessels are for use with Racor Hydrocarbon ACP, RAC and CP Series Coalescers and SP, SS, ST, RSS and RST Series Separator Cartridges. Racor hydrocarbon RVFS / RFHS Series two-stage coalescer/separator housings are designed to filter solids and separate water from fuel. Using the correct combination of Racor hydrocarbon coalescer cartridges and second stage separator cartridges will provide the highest degree of water and solids removal.



Vertical Coalescer Separators (FWS)	Diesel gpm	Kerosene gpm
RVFS-244-233	135	200
RVFS-344-333	200	300
RVFS-444-333	270	400
RVFS-556-444	420	600
RVFS-656-444	500	800
RVFS-856-644	670	1000
RVFS-956-744	750	1200

Industrial Filter/Water Separator Vessels

Horizontal and Vertical Vessels

RVFS Series

Applications for Racor RVFS Series filter vessels include removing liquid and solid contaminants from diesel fuel, gasoline, kerosene, aviation gas, jet fuel, and other lubricating or hydraulic oils. RVFS vessels utilize proven filter design technology and can be used as a coalescer, separator, water absorber, or clay treater by changing internal components, flow direction, or by selecting optional filter cartridges when ordering. The vessels are fabricated from carbon steel with an exterior primer coating and the interior is epoxy coated to meet MIL-C-4556E.

Filter choices include a coalescer, separator, pre-filter, and water absorber or clay treater.

Completely dressed factory filter vessels can be specified with differential pressure gauges, water sight glasses, air eliminators, and manual or automatic drains. Wall mount units can be special ordered.

Pressure Rating:

250 PSI (17.2 bar)
ASME Code Section VIII
or 148PSI (10 bar) CE marked to PED.

We manufacture CE marked vessels in Europe - specifications are the same as the RVFS vessels manufactured at Racor USA (see table below.)



Specifications	RVFS-1	RVFS-2	RVFS-3	Europe Options
Inlet and Outlet Ports	2.0 in. NPT	2.0 in. NPT	2.0 in. NPT	The RVFS is available with PED / CE approval and is manufactured in Europe.
Maximum Flow Rate (diesel)	25 GPM (94 LPM)	50 GPM (189 LPM)	75 GPM (283 LPM)	
Vent and Relief Ports	3/4 in. NPT	3/4 in. NPT	3/4 in. NPT	
Water Level Gauge Ports	1/2 in. NPT	1/2 in. NPT	1/2 in. NPT	
Differential Gauge Ports	1/8 in. NPT	1/8 in. NPT	1/8 in. NPT	
Pressure and Temperature	250 PSI @ 250°F (17 bar @ 121°C)			This part numbering uses the suffix below, the technical information is as per the table to the left.
ASME Code Stamped	Yes	Yes	Yes	
Clean Pressure Drop	2 PSID (0.14 bar)	2 PSID (0.14 bar)	2 PSID (0.14 bar)	AO
Pressure Drop/Filter Change-out	15 PSID (1.0 bar)	15 PSID (1.0 bar)	15 PSID (1.0 bar)	AO = All Options
Height	35.3 in. (89.7 cm)	49.8 in. (126.5 cm)	63.8 in. (162.1 cm)	MO
Width	13.5 in. (34.3 cm)	13.5 in. (34.3 cm)	13.5 in. (34.3 cm)	MO = Minimal Options
Depth	13.2 in. (33.5 cm)	13.2 in. (33.5 cm)	13.2 in. (33.5 cm)	SO
Dry Weight	100 lbs. (45 kgs)	115 lbs. (52 kgs)	130 lbs. (59 kgs)	SO = Selected Options
Overhead Service Clearance	16.0 in. (40.6 cm)	32.0 in. (81.3 cm)	47.0 in. (119.4 cm)	

Note: For additional information, request brochure 7537 or 7648.

Replacement Filter Options

RVFS-1**	Micron	Description	RVFS-2**	Micron	Description	RVFS-3**	Micron	Description
HOCP-15801	1	Coalescer	HOCP-30801	1	Coalescer	HOCP-44801	1	Coalescer
HSP-15401	1	Separator	HSP-30401	1	Separator	HSP-44401	1	Separator
HOCP-15805	5	Coalescer	HOCP-30805	5	Coalescer	HOCP-44805	5	Coalescer
HSP-15405	5	Separator	HSP-30405	5	Separator	HSP-44405	5	Separator
HOCP-15810	10	Coalescer	HOCP-30810	10	Coalescer	HOCP-44810	10	Coalescer
HSP-15410	10	Separator	HSP-30410	10	Separator	HSP-44410	10	Separator
HOCP-15825	25	Coalescer	HOCP-30825	25	Coalescer	HOCP-44825	25	Coalescer
HSP-15425	25	Separator	HSP-30425	25	Separator	HSP-44425	25	Separator

Note: All vessels come equipped with Viton® o-rings and are compatible with biodiesel mixtures.** For RVFS-1, 2, and 3, customer must order one OCP and one SP filter. A fuel filter/water separator consists of one coalescer and one separator filter.

Crankcase Filtration

In a robust, compact package, the Racor Closed Crankcase Ventilation (CCV) Filter Systems provide superior oil coalescence and crankcase pressure control under the most severe conditions.

CCV systems eliminate crankcase emissions and provide a cleaner engine environment by performing the functions below:



- They reduce oil consumption by separating the oil from crankcase gases and returning the oil to the sump.
- The high-efficiency filter prevents fouling of the turbocharger and after-cooler.
- Keeps engine compartment and components clean.
- Filtered crankcase gas is returned to the engine intake system for re-combustion instead of polluting the environment.

Pop-up style indicator that alerts of a bypass condition and the need for a filter change.

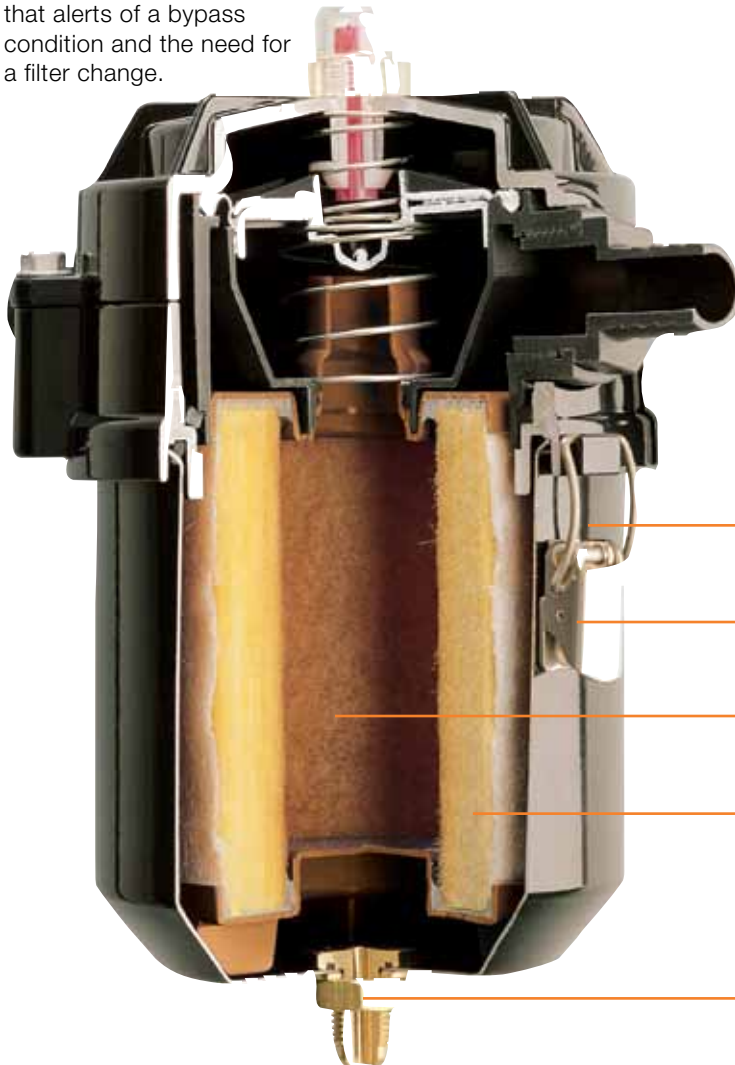

A unique crankcase pressure regulator with integral bypass valve minimizes variation in crankcase pressure. Excessive variation in crankcase pressure can damage seals, cause loss of oil, and other problems.

Left or right-hand inlet/outlet options.

High-efficiency oil separation down to 0.3 microns.

Durable glass-filled nylon and die cast aluminum components.

Steel with epoxy powder coating.

Stainless steel latches for tool-less filter change.

Replaceable high-performance filter with depth-loading, micro-glass fiber coalescing media.

Extended filter service interval from the Vaporbloc filter.

Drain check valve allows collected oil to be returned to the crankcase. This eliminates frequent draining and significantly reduces oil consumption.



CCV Operation

The only routine maintenance required for the Racor Closed Crankcase Ventilation filter system is filter replacement. Typical service life of the high performance filter in diesel applications is 750 hours. Some variations in service life occur depending on load profile, engine wear condition, flow, aerosol mass concentration of crankcase emissions, and soot concentration.

- CCV systems operate by filtering contaminants and coalescing oil mist from crankcase gases. The crankcase breather hose is connected to the 3/4" inlet hose barb of the CCV assembly. The connection at the engine can be positioned at the valve cover or crankcase.
- Filtered air from the CCV assembly is plumbed to the air intake system between the air filter and turbocharger.
- Coalesced oil drains from the filter sump to an external drain. A check valve holds oil in the line until it is released to the oil pan via a hose connection.
- The pressure regulating valve protects the engine from excessive crankcase vacuum.



Specifications	CCV4500	CCV6000	CCV8000	CCV12000
Maximum Flow Rate	10 CFM (283 LM)	20 CFM (566 LM)	40 CFM (1133 LM)	50 CFM (1416 LM)
Maximum Engine Rating	400 HP (298.3 KW)	800 HP (596.6 KW)	1600 HP (1193.1 KW)	2000 HP (1491.4 KW)
Inlet/Outlet Port Size	1 3/16"-12 STOR	1 5/8"-12 STOR	1 7/8"-12 STOR	1 7/8"-12 STOR
Weight (approx.)	3.3 lbs (1.5 kg)	5.0 lbs (2.3 kg)	8.7 lbs (3.9 kg)	9.3 lbs (4.2 kg)
Replacement Filter Media Density: Low	CCV55248-04	N/A	N/A	N/A
Replacement Filter Media Density: High	CCV55248-08	CCV55274-08	CCV55222-08	CCV55222-12-08
Replacement Filter Media Density: Ultra	CCV55248-10	CCV55274-10	CCV55222-10	CCV55222-12-10
Housing Material	Die cast head, glass-filled nylon and black powder epoxy-coated steel bowl.	Die cast head, glass-filled nylon and black powder epoxy-coated steel bowl.	Die cast head, glass-filled nylon and black powder epoxy-coated steel bowl.	Die cast head, glass-filled nylon and black powder epoxy-coated steel bowl.
Crankcase Pressure Regulator	Integral	Integral	Integral	Integral
Bypass/Change Indicator	Integral or Remote	Integral or Remote	Integral or Remote	Integral or Remote
Engine Block Check Valve Return Fitting	1/4" NPT	1/4" NPT	3/8" NPT	3/8" NPT
Swivel Fitting (Qty.)	#6 JIC (2 pcs.)	#6 JIC (2 pcs.)	#8 JIC (2 pcs.)	#8 JIC (2 pcs.)
Oil Drain Hose I.D.	0.375 in. (0.95 cm)	0.375 in. (0.95 cm)	0.5 in. (1.27 cm)	0.5 in. (1.27 cm)

Units can be manifolded to handle higher flow rates. Do not use CCV1500 in continuous duty applications.

Total Air Intake Solutions

Clean Up Engine Rooms and Engines

Marine diesel engines can benefit from the installation of a combination Racor Closed Crankcase Ventilation (CCV) and Air Filter/Silencer System. The CCV contains Racor's high-performance Vaporbloc™ filter made of depth-loading, micro-glass fiber coalescing media. The marine Air Filter/Silencer (AF) contains a washable media and is ruggedly built to provide an extended service life.



How the Systems Work

The engine crankcase breather is connected to the inlet of the Racor CCV assembly. The CCV outlet is connected to the engine's combustion air inlet via an air intake connector where filtered blowby gas is recycled through the combustion process. Oil collected in the CCV sump is returned to the crankcase through a hose and a drain check valve.

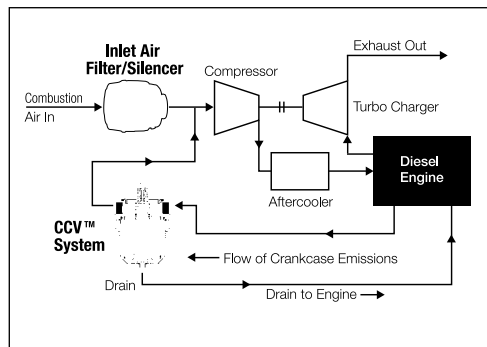

Marine Engine Application Worksheet

In order to determine the correct Racor CCV system for a particular application, certain engine information is required. A complete kit is composed of the following:

1. Racor CCV assembly
2. Fitting/Hose Kit
3. Air Intake Connector (Tap Sleeve or Marine Air Filter/Silencer Assembly)



1 Select the Racor CCV Assembly:

Racor CCV application is determined by crankcase flow in cubic feet per minute or CFM. Flow on new engines is low but as the engine wears on, the CFM increases. Select the correct Racor CCV model by dividing the engine horsepower output by 40.

For example:

CAT 3116/260HP ÷ 40 = 6.5 CFM, select CCV4500 or CAT 3406/525HP ÷ 40 = 13.13 CFM, select CCV6000

CCV units are designed to handle crankcase flow rates of up to 50 CFM (1416 l/m). Traditionally, the crankcase flow rate can be calculated as follows: Rated horsepower ÷ 40 = cubic feet per minute (CFM). This formula can only be used as a guide since recent improvements in piston design have produced engines with higher horsepower and lower blowby flow rates. The blowby flow rate of a worn engine, at time of overhaul, is generally double the flow rate when the engine is new. The flow rate of a worn engine is factored into the formula. **Note:** Specify left or right-hand inlet when ordering.

Air Filter/Silencers

The Racor Marine Air Filter/Silencer removes contaminants introduced into the air from both outside and inside the vessel. Sand, salt, carpet fibers, and other contaminants are trapped in the oil-impregnated Vaporbloc™ filter media. Turbo noise is reduced by the unique design of the housing. An integral hose connection on the housing routes the clean blowby from the CCV back into the engine.

- Pop-up style indicator alerts the operator of a bypass condition and the need for a CCV Vaporbloc™ filter change.
- Air Filter/Silencer is standard with an integral vent port for CCV connection.
- Air filter media is washable.
- Optional tap sleeves for easy connection of existing air cleaner to CCV assembly.
- Prevents turbo and intercooler fouling.

Maximum Flow Rate	
CCV Model	Flow
CCV4500	10 CFM (283 l/m)
CCV6000	20 CFM (566 l/m)
CCV8000	40 CFM (1133 l/m)
CCV12000	50 CFM (1416 l/m)



Cummins QSM11 marine engine with CCV cutaway



John Deere Marine PowerTech engine with Racor CCV/AF System



Marine Air Filter/Silencer (AF) System

Marine Air Filters (AF) typically correspond with the following CCV models, see chart below.

Marine Air Filter	CCV Model
AF M408512	CCV3500 or CCV4500
AF M501012	CCV4500 or CCV6000
AF M601212	CCV8000
AF M701212	CCV12000

2 Select a Fitting/Hose Kit:

Fitting/Hose Kits come with both fittings and enough hose for the inlet and outlet sides of the Racor CCV assembly. Racor CCV filter units require straight thread o-ring hose barb fittings available only from Racor distributors. In order to determine the correct application, you will need to know the quantity and the outside diameter of engine breather(s)/hose connection. Fitting/Hose Kits are available in various sizes and hose configurations.

3 Air Intake Connector Select A, B, or C, Depending on Application:

A. Tap Sleeve

Tap sleeves connect the Racor CCV outlet to the engine's air intake. Determine the inside diameter of the hose between the turbo and the air cleaner. This will determine the outside diameter of the tap sleeve required for completion of the installation of your Racor CCV system. Verify all dimensions required of the tap sleeve before ordering.

Example: John Deere #4045T — Hose between turbo and air cleaner is 4" inside diameter. Correct tap sleeve is CCV40100, which is 4" outside diameter with a 1" OD hose barb.

Tap Sleeves



Tap Sleeve	Dimensions		
	O. D.	Length	Hose Barb
CCV30100	3 in.	5 in.	1 in.
CCV40100	4 in.	5 in.	1 in.
CCV50125	5 in.	6 in.	1.1/4 in.
CCV60125*	6 in.	6 in.	1.1/4 in.

*Note: CCV60125 includes a 1 1/4" x 1 1/2" bushing (connects to 1 1/2" ID hose).

B. Hump Hose Fittings:

Use these with existing air cleaner-to-turbo rubber adapters.

Part Number	Hose
CCV55540	3/4 in.
CCV55113	1 in.
CCV55114	1 1/4 in.
CCV55115	1 1/2 in.



C. Marine Air Filter Silencer Assembly.

In order to determine the correct marine air filter application, you will need to know the engine's marine air filter rating (AFR) and provide the hose connection to turbo. Choose the correct marine air filter application per the following guideline. Verify that the marine air filter dimensions will fit into your engine room.

4-cycle engines: AFR = HP x 2.0

2-cycle engines: AFR = HP x 2.5

Marine Air Filter	Maximum Flow Rate
	Air Flow Rate
AF M408512	800 CFM (377 l/s)
AF M501012	1200 CFM (566 l/s)
AF M601212	1600 CFM (755 l/s)
AF M701212	2000 CFM (944 l/s)

Note: If AFR is close to maximum capacity of the marine air filter as listed above, use the next size larger.

Example: DDC 12V92TA DDEC (2-cycle - twin turbo):
 826 hp x 2.5 = 1032.5 AFR per turbo = (2) AF M501012
 1110 hp x 2.5 = 1387.5 AFR per turbo = (2) AF M601212
 CAT 3196 (4-cycle - twin turbo):
 660 hp x 2.0 = 1320.0 AFR = (1) AF M601212

Air Filter/Silencer



Specifications	AF M408512	AF M501012	AF M601212	AF M701212**
Max. Air Flow*	800 CFM (378 l/s)	1200 CFM (566 l/s)	1600 CFM (755 l/s)	2000 CFM (944 l/s)
Outlet Diameter	10.2 cm (4.0 in.)	12.7 cm (5.0 in.)	15.2 cm (6.0 in.)	17.8cm (7.0 in.)
Filter	AF M8040	AF M8050	AF M8060	AF M8070
Length	31.8 cm (12.5 in.)	31.8 cm (12.5 in.)	31.8 cm (12.5 in.)	31.8 cm (12.5 in.)
Depth	24.4 cm (9.6 in.)	29.2 cm (11.5 in.)	34.3 cm (13.5 in.)	34.3 cm (13.5 in.)
Hose Barb Size	2.5 cm (1.0 in)	3.2cm (1.25 in.)	3.2cm (1.25 in.)	2.5 cm (1.0 in)
Weight	1.9 kg (4.2 lbs)	2.3 kg (5.0 lbs)	3.6 kg (8.0 lbs)	3.6 kg (8.0 lbs)
Operating Temperature	-40° to +240°F (-40° to +116°C)			

*Values given are cubic feet per minute (CFM) and liters per second (l/s). **AF M701212-01 is available with a 1.25 in. hose barb.



Competitor Part Number	Racor Part Number	Dimensions D x H x D inches
CD170	AF M8145	10 x 8 x 10
CD174	AF M8121	7.5 x 6 x 7.5
CD175	AF M8122	7.5 x 7 x 7.5
CD178	AF M8126	7.5 x 10 x 7.5
CD180	AF M8010	3" Air Separator
CD183	AF M8153	12 x 12 x 12
CD184	AF M8037	9 x 14 x 6.875
CD185	AF M8047	10 x 14 x 7
CD186	AF M8152	12 x 7 x 12
CD189	AF M8157	12 x 14 x 12
CD190	AF M8026	7.5 x 10 x 5.125
CD195	AF M8025	7.5 x 8 x 5.125
CD196	AF M8034	9 x 9 x 7
CD197	AF M8033	9 x 12 x 6.88
CD200	AF M8134	9 x 9 x 9
CD201	AF M8133	9 x 12 x 9
CD202	AF M8141	10 x 6 x 10
CD204	AF M8156	12 x 12 x 8

Air Filter Replacements

Racor offers direct replacements for the intake air filter portion of competitive air filters/silencers. Also available is the replacement filter for the vacuum limiter air separator.

The filter media for all replacement filters is an oil-impregnated cotton gauze and is sandwiched between pleated, epoxy-coated aluminum wire-mesh with polyurethane sealing surfaces. This product is cleanable and must be oiled before re-using.



LG50 and LG100

LG50 (for gasoline)

Stage 1:



Venting tank fuel is diffused by the flow diverter and air is allowed to bypass the diverter. Fuel is directed back into the fuel tank.

Stage 2:

Vapor collects on the interior surfaces and coalesces. The fuel returns downward by gravity and air continues up and out of the unit.

LG100 (for diesel/gasoline)

Stage 1:



Venting tank fuel is diffused by the flow diverter and air is allowed to bypass the diverter. Fuel is directed back into the fuel tank.

Stage 2:

Fuel de-foams through a fine wire mesh screen which filters out large contaminants.

Under the screen, the fuel collects temporarily until it can freely flow back to the fuel tank.

Stage 3:

Vapor collects on the interior surfaces and coalesces. The fuel returns downward by gravity and air continues up and out of the unit.

Note: The safety relief valve includes a floating check ball which will not permit a large in-rush of fuel to bypass. In the event of internal pressure reaching 2.4 PSI (0.17 bar), the spring will compress and open the safety seat.

Eliminate Fuel Vent Line Overflow During Refueling



Next time you fill up, watch your fuel vent line. A typical refueling will send up to half a gallon or more of fuel spilling overboard. Fuel spillage is not only expensive, it's absolutely deadly to fragile lakes, rivers, and waterways. Also, USCG and other regulations prohibit the discharge of oils with civil and criminal penalties. Installed in the fuel tank vent line, the Racor Fuel/Air Separator efficiently separates air from fuel forced into the line. Air is vented, and all fuel is returned to the tank. The Fuel/Air Separator captures fuel normally discharged due to agitation and thermal expansion up to 2.4 PSI (0.17 bar). It also eliminates damage to expensive striping, labels, and protects finishes from fuel stains. The unit is also maintenance free—there's nothing to rust or corrode.

ECO Friendly



The Racor Fuel/Air Separator fits neatly into your vent line, actually replacing a section of the line and fittings are included with each kit. One Fuel/Air Separator unit is required for each vent line. Fuel/Air Separators fit 5/8" vent lines, 1/2" fittings are available.



Specifications	LG50	LG100
Application:		
Gasoline	Yes	Yes
Diesel	No	Yes
Maximum Air Flow	12 CFM (340 l/m)	17 CFM (481 l/m)
Hose Barb ¹	5/8"	5/8"
Thermal Expansion	Up to 2.4 PSI (0.17 bar)	Up to 2.4 PSI (0.17 bar)
Height	6.0 in. (15.2 cm)	9.8 in. (24.9 cm)
Diameter	1.8 in. (4.6 cm)	4.0 in. (10.2 cm)
Weight (dry)	1.2 lbs (0.5 kg)	1.6 lbs (0.7 kg)

Notes: ¹ Order part **RK 50033** for 1/2" NPTF threaded fitting)

New ABS Bypass Filters



The Absolute replacement filter is the heart of the Absolute bypass filtration system. Made from a special cellulose material wound onto a central core, it combines micro and depth filtration by using the axial filtration principle (flow direction from the top to the bottom).

A card sleeve compresses the lower part to increase the density. A non-woven cloth protects the base and stops particle and media migration.

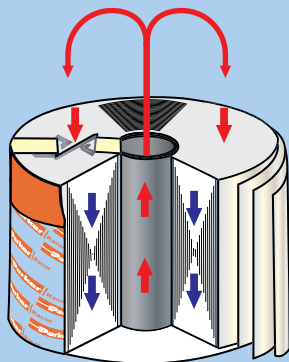

Oil Bypass Filtration

For many years Racor has sold the LFS 800, LFS 801, and LFS 802 bypass oil filters. These are string wound filters that capture moisture and engine damaging contaminants.

The heavy-duty LFS 800 series housings are dependable and designed for long life with many of these units still in service in the field, Racor will maintain replacement filters to service our valuable customers.



The list below shows the replacement filters for the respective LFS 800 series housings. In addition to the replacement filters, the chart below also shows the complete superseded part number which in many cases can replace the LFS 801 and LFS 802 series housings with minimal effort.

LFS 800 Series Typical Test Results

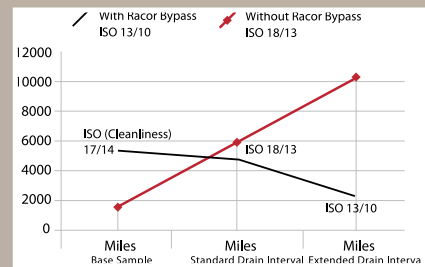

Ideal for heavy-duty applications!

Bypass Oil Series Benefits

- Extends the miles/hours between oil changes
- Saves maintenance costs and downtime
- Keeps oil cleaner longer, reducing oil consumption and disposal
- Extends engine life and “re-build” intervals
- Keeps engines better lubricated which means reduced wear
- Removes damaging moisture



LFS 800 Assembly	LFS 800 Replacement Filter	Superseded Absolute Assembly	Absolute Replacement Filters		
			3 micron	5 micron	10 micron (Long Life)
LFS 801	LFS 801BPE	ABS10300	ABS20330	ABS20370	ABS25350
LFS 802	LFS 802BPE	ABS10450	ABS20430	ABS20470	ABS25450

Racor Absolute Series



Specifications	ABS10300	ABS10450
Maximum Pressure	180 PSI (12.4 bar)	180 PSI (12.4 bar)
Capacity	30 qts (28 L)	50 qts (47 L)
Port Size (inlet/outlet)	1/4" NPTF	1/4" NPTF
Dimensions	W6.38 x D6.54 x H12.48 in. (W162 x D166 x H317 mm)	W8.03 x D8.11 x H12.64 in. (W204 x D206 x H321 mm)
Replacement Filters	ABS20330 (3 micron) ABS20370 (5 micron) ABS25350 (10 micron)	ABS20430 (3 micron) ABS20470 (5 micron) ABS25450 (10 micron)
Weight	10 lbs (4.5 kg)	15 lbs (6.8 kg)
Seal Kit	ABS44030	ABS44045

Features

The Absolute Series provides continuous oil cleaning during engine operation. The filter design, shape, and tensioning of the media guarantees absolute filtration of solid particles and moisture.

- Continuous Oil Purification
- Longer Oil Life
- Longer Engine Life
- Improved Fuel Economy
- Reduce - Reuse - Recycle
- No certification needed, just install and reap the benefits!

SU Series



Specifications	ABS11200	ABS11300
Housing Material	Stainless Steel	Stainless Steel
Capacity	100 qt (94.6 L)	150 qt (142.0 L)
Port Size	1/2" NPT	1/2" NPT
Working Pressure	<120 PSI (8.3 bar)	<120 PSI (8.3 bar)
Dimensions	W9.3 x D10.6 x H16.1 in. (W236 x D269 x H409 mm)	W9.3 x D10.6 x H30.0 in. (W236 x D269 x H762 mm)
Replacement Filters	(use two) ABS20430 (3 micron) ABS20470 (5 micron) ABS25450 (10 micron)	(use three) ABS20430 (3 micron) ABS20470 (5 micron) ABS25450 (10 micron)
Weight	22 lbs (10.0 kg)	28.7 lbs (13.0 kg)
Seal Kit	ABS44090	

SU and SS Series Large Volume

These high-capacity filtration units are designed to efficiently and cost effectively clean large volumes of lubrication fluids. It combines Racor's unique depth loading filter for removal of wear particles, moisture, and sludge in large engine applications.

SS Series



Specifications	ABS11400	ABS11410	ABS10515
Housing Material	Carbon Steel	Carbon Steel	Carbon Steel
Capacity	100 qt (94.6 L)	150 qt (142.0 L)	250 qt (236.6 L)
Port Size (inlet/outlet/drain)	1/2" NPTF	1/2" NPTF	1/2" NPTF
Working Pressure	<72.5 PSI (5.0 bar)	<72.5 PSI (5.0 bar)	<72.5 PSI (5.0 bar)
Dimensions	W11.81 x H23.62 in. (W300 x H600 mm)	W11.81 x H29.25 in. (W300 x H743 mm)	W18.9 x H50.0 in. (W480 x H1270 mm)
Replacement Filters	(use two) ABS20430 (3 micron) ABS20480 (5 micron) ABS25450 (10 micron)	(use three) ABS24030 (3 micron) ABS20490 (5 micron) ABS25450 (10 micron)	(use five) ABS20520 (3 micron)
Weight	40 lbs (18.1 kg)	48.5 lbs (22 kg)	191 lbs (86.6 kg)
Seal Kit	ABS44080		

Vacuum/Compound Gauge Kits

Vacuum and Compound (vacuum/pressure) gauges and related hardware are available to monitor filter condition. As the filter slowly becomes clogged with contaminants the restriction (resistance to flow) increases. The fuel pump still tries to draw fuel (suction) but because of this restriction less fuel is delivered to the engine and instead more air is pulled from it (fuel de-gassing). These results can cause the engine to lose power and eventually stall. By installing a vacuum gauge in your fuel system (on the outlet side of the Racor filter) visual monitoring of filter condition is possible at a glance. Note the position of the dial, or apply the 'red line' decal provided with most kits. This will assist in easy monitoring as filter efficiency begins to decrease when a filter change is necessary.

Note: Intervals of filter changeout may vary depending on fuel cleanliness. Always keep a spare Racor filter on hand.



RK11-1676E
Vacuum Gauge

Filtration Accessories

Enhance Your Fuel Systems Performance and Ease of Service

When is My Engine Air Filter "Used Up?"

Because it performs so well, it is not uncommon for the engine air filter to appear as if it has reached its capacity. The only way to know when the engine air filter has reached it's capacity is to measure the restriction at service.

An effective way to verify restriction is with a filter restriction monitor. A restriction monitor will provide a quick and accurate assessment of the air filter's condition and remaining service life.



Standard Filter Monitor Part Numbers

Part Number	Range (In. water vac.)	Description
400033015 ^A	8-15 inHg (27-51 kPa)	Direct Mount
400033020 ^A	8-20 inHg (27-68 kPa)	Direct Mount
400033025 ^A	8-25 inHg (27-85 kPa)	Direct Mount
014440001 ^A	8-25 inHg (27-85 kPa)	Direct Mount w/ 90° Fitting
072604000 ^B	4-25 inHg (14-85 kPa)	Remote Mount
076248001 ^A	8-25 inHg (27-85 kPa)	Dash Mount

^A Unit standard with a 1/8"-27 NPT straight fitting.

^B Unit standard with a 90° coupling and 10' hose.

Part No.	Description	Tread Size	
RK 11233	Vacuum Gauge, Silicone Dampened, 2" dial, 0-30 inHg. (0-15 PSI)	1/4" NPT Back Mount With Bracket	
1606B	Vacuum Gauge Kit. Gauge (RK 11233), one 7232-4, And One 7234-4 Fitting	1/4" NPT Back Mount With Bracket	
7232-4	Adapter Fitting	1/8" MNPT x #4 (1/4") Hose	
7234-4	Adapter Fitting	1/4" Swivel x #4 (1/4") Hose	
0102-4-2	Adapter Fitting	1/4" NPTM x 1/8" NPTF	
RK11-1676E	Vacuum Gauge With 2" Dial, Rotating Bezel, And Red Tell-Tale Pointer. 0-30 inHg. (0-15 PSI)	1/4" NPT Bottom Mount	
RK11-1969	T-Handle Vacuum Gauge (for 500FG Turbine series fuel filter/water separators)	1/4" NPT x 3/4" Fitting Threads	
RK 11-1669	T-handle Vacuum Gauge (for 900 and 1000 Turbine series fuel filter/water separators)	1/4" NPT x 1" Fitting Threads	
RK 19492	UL-Listed Brass Drain Valve	1/4" NPTF	

Water Detection Modules & Kits

Racor Water Detection Kits are available in a wide selection for various installation requirements. Under-dash, in-dash, and remote mount, these solid-state units may be used with any Racor fuel filter/water separator and water probe. They are manufactured using the highest quality materials and are all 100% electrically tested.

An electronic detection module analyzes electrical resistance at the water probe and determines if water is present. If so, the detection module operates to indicate water, based on its features listed below. All units reset automatically after water is removed (unless specified).

Caution: The water probe and detection modules work with 12 or 24 volts, direct current only and should never be wired to other brand modules or household 110 or 220 volts, alternating current. Use the guide below to find the correct detection module for your application.

Part Number	Description	Voltage	Image
RK 12870	Under-dash water detection module. Light illuminates and alarm sounds when water is detected. Water must be drained to reset light and stop alarm. Plastic enclosure measures: 1.38" square x 1.25" deep. Water probe included.	12 vdc	
RK 12871	Same as above	24 vdc	
RK 20725	Under-dash mount water detection module. Light only. Green 'ON' lamp illuminates with power on. Red 'DRAIN' lamp illuminates when water is detected. Initial power-up self diagnosis feature and circuit protection included. Plastic enclosure measures: 2.75" x 1" x 1.5". Water probe included.	12 vdc	
RK 20725-24	Same as above	24 vdc	
RK 20726	2" gauge-type water detection module. Light and audio. Red 'DRAIN' lamp illuminates and horn sounds when water is detected. Initial power-up self diagnosis feature and circuit protection included. Plastic case, satin black dial with white lettering. Water probe included.	12 or 24 vdc	
RK 11-1570	2" gauge-type water detector and filter restriction module. Includes pre-set vacuum switch (7 inHg), connector, and outlet adapter fitting. Red 'DRAIN' or 'CHANGE FILTER' lamp illuminate and horn sounds when water is detected. Water probe included.	12 or 24 vdc	
RK 14329	Remote detection unit sends 12 VDC hot (+) signal when an input ground signal (from a water probe or a vacuum switch—not included) is received. Must be used with a relay to power a horn or indicator lamp (if draw is over 1 amp). Plastic enclosure measures: 3" x 2.5" x .75"	12 vdc	
RK 14321	Same as above	24 vdc	
14332	Under-dash mounts same as RK 14329 but sends a ground (-) signal. Enclosure size is same as RK 20725 above.	12 vdc	
RK 20163	Vacuum Switch Kit Non-adjustable, 'Normally Open' contacts close at 7 inHg (3.4 PSI) 1/8"-27 NPT threads. For use with all models.	N/A	
RK 21030	Vacuum Switch Connector Kit Molded connector with single 18 AWG., 18" blue wire lead.	N/A	
RK30880E	This kit includes new and enhanced detection electronics built into the probe body and works with 12 or 24 volt DC systems. Water probe and detection module all in one.	12 or 24 vdc	

Clear collection bowl must have a 7/8" SAE port.

Water Detection Probes



Water Probes

Water probes simply provide metal pin tip entry into a water collection bowl. Some contain no active electronics and require an external electronic detection module to detect water.

Racor offers a wide selection of water-in-fuel (WIF) detection systems, each designed for specific filter assemblies and installation requirements.

Electronic Detection Modules
Detection modules have internal electronics that pass a small current across special metal pins. When water bridges the pin tips, a solid state switch is activated allowing a larger current to flow to drive a light

or provide a signal to an engine computer. Electronic detection modules will automatically reset once water is drained away from the probe tips.

Detailed instructions are supplied with every WIF sensor and electronic detection module.

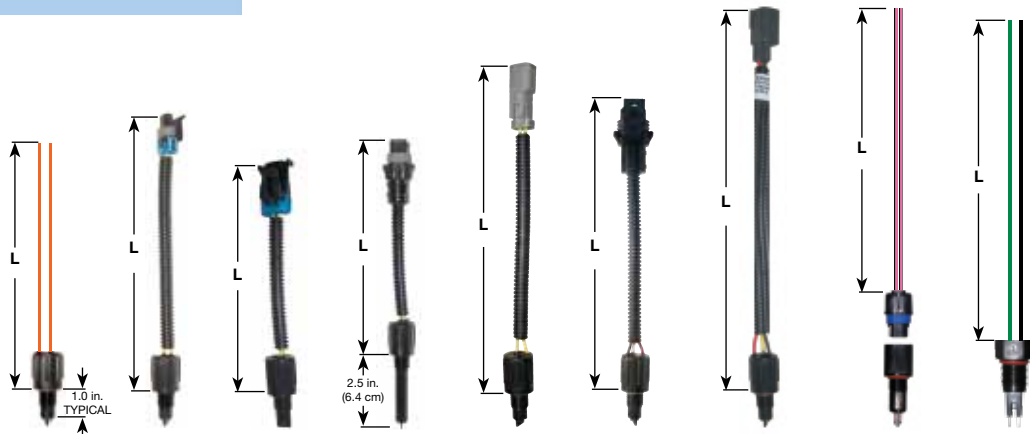

Specifications	RK32262-02	RK 55484	56140	RK56140-01	RK55617	RK30880E**	RK30880-03**	RK 30964	RK 21069
Mating Connector	None	Delphi Packard 12162000	Delphi Packard 12162000	Delphi Packard 12162000	N/A	Racor 22556	Yazaki 7283-7031-10	None	None
Thread Size	1/2"-20 UNF								
Volts	12	12 or 24	12	12	12	12 or 24	12 or 24	12 or 24	12 or 24
Probe Tips	Beryllium Copper	Gold Plated Nickel	Beryllium Copper	Beryllium Copper	Beryllium Copper	Beryllium Copper	Beryllium Copper	Stainless Steel	Stainless Steel
Wire Length (L)	7.0 in. (17.8 cm)	8.0 in. (20.3 cm)	6.0 in. (15.2 cm)	6.0 in. (15.2 cm)	8.7 in. (22.1 cm)	8.0 in. (20.3 cm)	11.0 in. (27.9 cm)	8.0 in. (20.3 cm)	8.5 in. (21.6 cm)
Internal Resistor	83K ohm	220K ohm	220K ohm	220K ohm	82.5K ohm	Amplifier	Amplifier	None	None
Application	Cummins ISC03/ISL03	Cummins	-	John Deere	Cummins	All	Hino	All	All
Output	-	-	-	-	-	To Ground	To Ground	-	-

** These WIF probes have a built-in water detection module.

Racor Water Makers

Why Choose a Racor Village Marine Water Maker?

Providing a variety of reverse osmosis desalination units to every size vessel in production, past and present. Racor VMT has an unsurpassed reputation of manufacturing the best built water maker equipment with unparalleled level of factory support. Racor VMT produces over 95% of all components in their systems in house. Racor VMT is the TRUE manufacturer of reverse osmosis desalination equipment.

Pacific Asian Enterprises and Nordhavn Yacht owners rely on Racor VMT to provide world class service. Peace of mind is one of the major keys to having a successful extended underway period. Racor VMT assists the operators and crew of these fine vessels with that peace-of-mind by providing safe, efficient, and reliable equipment accompanied by

the best factory and technical support possible.

There is no longer a need to store additional water on board vessels in water bottles. Make water at sea and forget about having to return to dock just to re-fill the water tanks. Racor VMT is proud to provide all of your fresh water needs and the highest level of expertise and support possible.



Master Control Panel

Parker technology is now at your fingertips and can be utilised with the Stowaway series of watermakers.

A multi-function graphical interface makes boating and watermaking as easy as using your mobile phone. Step up to the 21st century and choose your watermaker from the global leader in motion and control technology - Parker.

The Stowaway Series features a semi modular frame format, which maximizes installation flexibility. The frame is compact and can be above or below water line. The boost pump and prefilters are supplied as loose items. The watermaker can be operated and monitored from the electronic remote control.

The Stowaway Series offers fresh water independence for ocean crossings, extended fishing trips or cruising where dock supplies are unreliable.



Racor Water Maker Overview

For Reverse Osmosis Applications

Racor is the watermaker of choice for the experienced sailor. Racor units come equipped with corrosion resistant pumps, membranes, and controls. The result is the most reliable, field serviceable, quiet, efficient, and economical source of fresh water available in the industry. Available in a self-contained frame, semi-modular, or completely modular configurations with water output ranging from 145 to 100,000 GPD.

LT Modular Series (LTM)

The LTM Series offers high quality Racor Village Marine engineered components with straightforward manual operation. Driven by AC motors (from genset power), the modular configuration comes in ready to mount modules for flexible installation options. Integral to every LTM unit are a stainless steel pressure regulator and bypass valve.



LTM Series



LWM Series

LW Modular Series (LWM)

The LWM is the watermaker of choice for the experienced sailor. The LWM comes equipped with a corrosion resistant, single piston, belt driven, low RPM high-pressure pump. Result is the most reliable, field serviceable, quiet, efficient and economical source of fresh water available in completely modular configurations with water output ranging from 145 to 200 GPD. The LWM watermakers are designed for cruising sail boats where space is limited and reliability is required.

PW Series Horizontal

The PW Series reverse osmosis desalination systems are the preferred choice of reliable fresh water generating equipment for the most demanding marine operators (such as major oil companies, The United States Navy, The United States Coast Guard and The Cousteau Society). Thousands of PW installations have proven the performance and longevity under the most rugged conditions.



PW Series



PWV-2000 Series

PW Vertical (PWV) Series

The PWV Series is designed to provide installation flexibility, superior performance, and extended service life in the most rugged conditions. Designed for 24/7, continuous-duty applications, where reliable fresh water supply is critical. The fully framed unit is standard, however semi-modular and fully modular versions are also available.

SW Series



Features and Benefits

- Sea strainer (prevents large particles from entering into the system)
- Media filter (with simple back-flush and rinse controls)
- Pre-filtration housings
- Ceramic plunger titanium pump
- Corrosion resistant low-pressure pumps
- Stainless steel, glycerine filled pressure gauges
- High-pressure hose (with titanium fittings)
- Standard sized membranes
- 316 Stainless steel high-pressure bypass valve
- Adjustable 316 stainless steel pressure regulating valve
- Brine water flow meter
- Product flow meter
- Automatic diversion valve
- Digital water quality monitor
- Cleaning valve
- Freshwater flush system

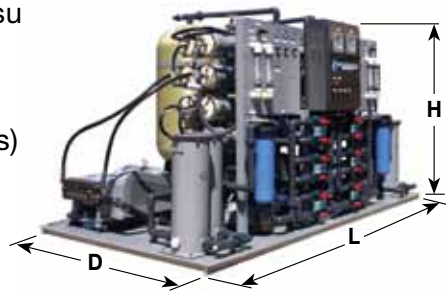

SW Systems

Systems are designed for rugged use in harsh environments where a large quantity of potable water is required. Typical installations are offshore rigs, work camps, oceanfront resorts, and cruise ships.

Each SW unit comprises a single skid installation with two complete, independent reverse osmoses (RO) systems. The two trains can both run or can be operated on a duty/stand-by basis.

Special Features

- 24,000–40,000 GPD unit capacity
- Exclusive corrosion resistant titanium head with five plunger pumps
- 316 stainless steel high pressure regulating valves
- Corrosion-resistant FRP pressure vessels
- All corrosion resistant hardware and fasteners
- Backwashable media filters
- Optional FRP piping and polypropylene valves



Model	Product Flow ¹	Power at 440/3/60	Skid Size LxDxH	Operating Weight
SW 24	24000 GPD (91 m ³ /day)	60 Amps	142 in. (361 cm) x 72 in. (183 cm) x 78 in. (198 cm)	6950 lbs (3152 kg)
SW 32	32000 GPD (121 m ³ /day)	60 Amps	142 in. (361 cm) x 72 in. (183 cm) x 78 in. (198 cm)	7300 lbs (3311 kg)
SW 40	40000 GPD (151 m ³ /day)	70 Amps	142 in. (361 cm) x 72 in. (183 cm) x 78 in. (198 cm)	7500 lbs (3402 kg)

¹ Product flow based on median seawater conditions, and both trains running.

PW Systems

PW systems are the preferred choice for some of our most discriminating clients (such as the United States Navy, Coast Guard, and the Cousteau Society) and have proven to be among the most reliable units on the market. These systems are designed to provide the best performance and longevity under the most rugged conditions.

Available In Two Styles:

Framed: Framed units are the most convenient to install—simply connect hoses, run the power, and you're in business.

Modular: Modular systems allow the user freedom to install components where space permits, and the modules are small enough to fit through hatchways for installation.

Optional Accessories

- Cyclone separator (for sandy water conditions).
- Hand-held digital water tester (tests water to World Health organization standards—500 ppm). Reads 0-999 ppm.
- Hazardous area classification Class I, Div I, Group D.
- Media filter (extends the life of micron filters).
- FRP low-pressure piping.

PW Series



Features and Benefits

- Sea Strainer and filtration housings
- Ceramic plunger titanium pump
- Boost pump (up to 50 PSI pressure)
- Stainless steel, glycerine filled pressure gauges
- High-pressure piping
- Standard sized membranes
- Easy to operate 316 stainless steel high pressure bypass valve
- Adjustable 316 stainless steel pressure regulating valve
- Brine water flow meter
- Product flow meter
- Automatic diversion valve (diverts water to discharge)
- Digital water quality monitor (displays ppm TDS of product water output)
- Cleaning valve
- Non-corrosive, aluminum, powder coated frame
- FRP pressure vessels
- Simple to use fresh water flush system (extends life of membranes without use of preservatives)

Model	Capacity	Power HP	Dimensions W x D x H	Weight lbs./kg
PW3000	125 GPH (11 m ³ /D)	12 HP (8.9 KW)	84 in. (213.4 cm) x 34 in. (86.4 cm) x 35 in. (88.9 cm)	800 lbs (363 kg)
PW4000	167 GPH (15 m ³ /D)	12 HP (8.9 KW)	84 in. (213.4 cm) x 34 in. (86.4 cm) x 35 in. (88.9 cm)	900 lbs (408 kg)
PW5000	208 GPH (19 m ³ /D)	17 HP (12.7 KW)	84 in. (213.4 cm) x 34 in. (86.4 cm) x 35 in. (88.9 cm)	1000 lbs (454 kg)
PW6000	250 GPH (23 m ³ /D)	17 HP (12.7 KW)	84 in. (213.4 cm) x 44 in. (111.8 cm) x 35 in. (88.9 cm)	1050 lbs (476 kg)
PW7000	292 GPH (27 m ³ /D)	17 HP (12.7 KW)	84 in. (213.4 cm) x 48 in. (121.9 cm) x 35 in. (88.9 cm)	1500 lbs (680 kg)
PW8000	333 GPH (30 m ³ /D)	22 HP (16.4 KW)	84 in. (213.4 cm) x 48 in. (121.9 cm) x 35 in. (88.9 cm)	1600 lbs (726 kg)
PW10000	417 GPH (38 m ³ /D)	22 HP (16.4 KW)	84 in. (213.4 cm) x 48 in. (121.9 cm) x 35 in. (88.9 cm)	1800 lbs (816 kg)
PW12000	500 GPH (45 m ³ /D)	27 HP (20.1 KW)	88 in. (223.5 cm) x 52 in. (132.1 cm) x 35 in. (88.9 cm)	1900 lbs (862 kg)
PW16000	667 GPH (61 m ³ /D)	27 HP (20.1 KW)	88 in. (223.5 cm) x 52 in. (132.1 cm) x 43 in. (109.2 cm)	2200 lbs (998 kg)
PW20000	833 GPH (76 m ³ /D)	32 HP (23.9 KW)	88 in. (223.5 cm) x 52 in. (132.1 cm) x 43 in. (109.2 cm)	2250 lbs (1021 kg)

Note: Also available in explosion proof configuration for installation on oil and gas rigs. NEC rating, Class I, Division I, Group D. PW modular units dimensions and weights are available upon request. All other specifications are the same as the framed units.

Bilge Water Membrane Separators

Racor Bilge Water Membrane Separator units are designed to meet the needs of the ship owners, engineers, crew who want to reduce the overboard discharge of accumulated bilge water which might contain harmful oils or other contaminants.

With heavy duty construction, corrosion resistant materials, permanent oil attractant media, quiet operation, automatic diversion valves and advanced Racor membrane technology

result in an easy to use, fully automated, high quality, affordable solution to meet your bilge water treatment needs.

The BMS is fully certified under the IMO resolution MEPC 107(49) and implements an advanced three-stage system optimizing the separation and removal of free and emulsified oils.



Three treatment stages

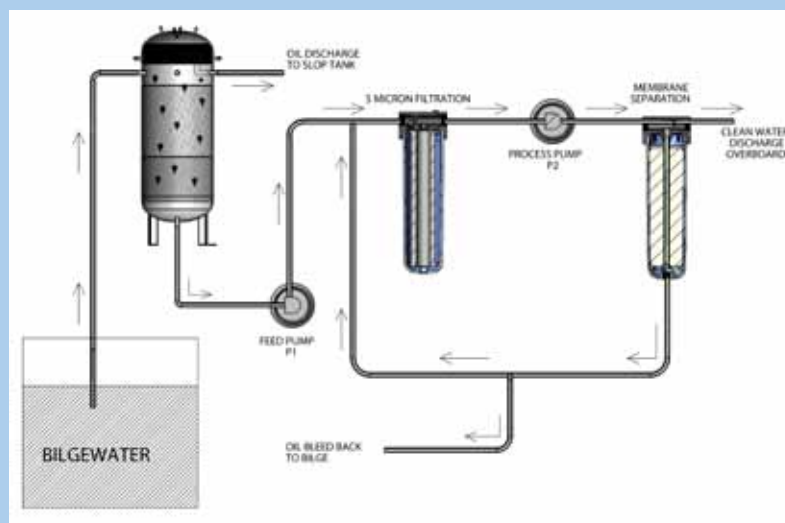

1. Coalescing
Self cleaning attractant media collects free floating oil, where it is discharged to the slop tank.

2. Filtration
5 micron filtration to remove solids.

3. Separation
Oleophilic membrane separates clean water from any emulsified oil.

Features and Benefits

- USCG Certified to meet IMO MEPC 107(49) regulations
- MEPC 107(49) certified oil content monitor included
- Advanced three-stage design for maximum oil separation
- Fully automated system
- Racor membrane technology specifically designed for bilge water treatment
- Compact design minimizes storage space
- System employs a self-cleaning cycle for prolonged membrane service life
- Positive shut-off solenoid valves for operational reliability

Parker Racor Division Quality Management System Certifications

- ISO/TS 16949: 2002
- ISO 14001: 2004

WARNING: Failure or improper selection or improper use of the products and/or systems described herein or related items can cause death, personal injury, and property damage. This document and other information from Parker Hannifin Corporation, its subsidiaries and authorized distributors provide product and/or system options for further investigation by users having technical expertise. It is important that you analyze all aspects of your application and review the information concerning the product or system in the current product catalog. Due to the variety of operating conditions and applications for the products or systems, the user, through its own analysis and testing, is solely responsible for making the final selection of the products and systems and assuring that all performance, safety, and warning requirements of the application are met. The products described herein, including with limitation, product features, specification, designs, availability and pricing, are subject to change by Parker Hannifin Corporation and its subsidiaries at any time without notice.

Parker's Product Information Centre

Parker Hannifin has become a world leader in motion and control technology by providing premier customer service. That's what our Product Information Center is all about. Our experienced agents are ready to provide you with the product identification and referral service you need. Emergency breakdown calls are relayed via pager to agents on call who will respond promptly. Non-emergency calls are recorded and answered the next business day.

Tap Into the Knowledge Network

Every agent has access to extensive computer databases referenced by part number and product category. Information encompassing 200 worldwide facilities, 400 product lines, and 1,200 market segments is at their fingertips. Our goal is to make it as easy as possible for you to do business with Parker.

Language Line Service

By using the Language Line Service, we can access interpreters for more than 140 languages immediately. Handling non-English-speaking inquiries is not a problem!



Parker's Motion & Control Technologies



AEROSPACE

Key Markets

- Aircraft engines
- Business & general aviation
- Commercial transports
- Land-based weapons systems
- Military aircraft
- Missiles & launch vehicles
- Regional transports
- Unmanned aerial vehicles

Key Products

- Flight control systems & components
- Fluid conveyance systems
- Fluid metering delivery & atomization devices
- Fuel systems & components
- Hydraulic systems & components
- Inert nitrogen generating systems
- Pneumatic systems & components
- Wheels & brakes



CLIMATE CONTROL

Key Markets

- Agriculture
- Air conditioning
- Food, beverage & dairy
- Life sciences & medical
- Precision cooling
- Processing
- Transportation

Key Products

- CO² controls
- Electronic controllers
- Filter driers
- Hand shut-off valves
- Hose & fittings
- Pressure regulating valves
- Refrigerant distributors
- Safety relief valves
- Solenoid valves
- Thermostatic expansion valves



ELECTROMECHANICAL

Key Markets

- Aerospace
- Factory automation
- Food & beverage
- Life science & medical
- Machine tools
- Packaging machinery
- Paper machinery
- Plastics machinery & converting
- Primary metals
- Semiconductor & electronics
- Textile
- Wire & cable

Key Products

- AC/DC drives & systems
- Electric actuators
- Controllers
- Gantry robots
- Gearheads
- Human machine interfaces
- Industrial PCs
- Inverters
- Linear motors, slides and stages
- Precision stages
- Stepper motors
- Servo motors, drives & controls
- Structural extrusions



FILTRATION

Key Markets

- Food & beverage
- Industrial machinery
- Life sciences
- Marine
- Mobile equipment
- Oil & gas
- Power generation
- Process
- Transportation

Key Products

- Analytical gas generators
- Compressed air & gas filters
- Condition monitoring
- Engine air, fuel & oil filtration & systems
- Hydraulic, lubrication & coolant filters
- Process, chemical, water & microfiltration filters
- Nitrogen, hydrogen & zero air generators



FLUID & GAS HANDLING

Key Markets

- Aerospace
- Agriculture
- Bulk chemical handling
- Construction machinery
- Food & beverage
- Fuel & gas delivery
- Industrial machinery
- Mobile
- Oil & gas
- Transportation
- Welding

Key Products

- Brass fittings & valves
- Diagnostic equipment
- Fluid conveyance systems
- Industrial hose
- PTFE & PFA hose, tubing & plastic fittings
- Rubber & thermoplastic hose & couplings
- Tube fittings & adapters
- Quick disconnects



HYDRAULICS

Key Markets

- Aerospace
- Aerial lift
- Agriculture
- Construction machinery
- Forestry
- Industrial machinery
- Mining
- Oil & gas
- Power generation & energy
- Truck hydraulics

Key Products

- Diagnostic equipment
- Hydraulic cylinders & accumulators
- Hydraulic motors & pumps
- Hydraulic systems
- Hydraulic valves & controls
- Power take-offs
- Rubber & thermoplastic hose & couplings
- Tube fittings & adapters
- Quick disconnects



PNEUMATICS

Key Markets

- Aerospace
- Conveyor & material handling
- Factory automation
- Food & beverage
- Life science & medical
- Machine tools
- Packaging machinery
- Transportation & automotive

Key Products

- Air preparation
- Compact cylinders
- Field bus valve systems
- Grippers
- Guided cylinders
- Manifolds
- Miniature fluidics
- Pneumatic accessories
- Pneumatic actuators & grippers
- Pneumatic valves and controls
- Rodless cylinders
- Rotary actuators
- Tie rod cylinders
- Vacuum generators, cups & sensors



PROCESS CONTROL

Key Markets

- Chemical & refining
- Food, beverage & dairy
- Medical & dental
- Microelectronics
- Oil & gas
- Power generation

Key Products

- Analytical sample conditioning products & systems
- Fluoropolymer chemical delivery fittings, valves & pumps
- High purity gas delivery fittings, valves & regulators
- Instrumentation fittings, valves & regulators
- Medium pressure fittings & valves
- Process control manifolds



SEALING & SHIELDING

Key Markets

- Aerospace
- Chemical processing
- Consumer
- Energy, oil & gas
- Fluid power
- General industrial
- Information technology
- Life sciences
- Military
- Semiconductor
- Telecommunications
- Transportation

Key Products

- Dynamic seals
- Elastomeric o-rings
- EMI shielding
- Extruded & precision-cut, fabricated elastomeric seals
- Homogeneous & inserted elastomeric shapes
- High temperature metal seals
- Metal & plastic retained composite seals
- Thermal management

Rely on premium boat fuel systems by Racor Division if you're looking for quality and efficiency.