

ECI-100 Engine & Control Interface



Installation instructions

Trademark and patents notice

Autohelm, hsb², RayTech Navigator, Sail Pilot, SeaTalk, SeaTalk^{NG}, SeaTalk^{HS} and Sportpilot are registered trademarks of Raymarine UK Limited. RayTalk, Seahawk, Smartpilot, Pathfinder and Raymarine are registered trademarks of Raymarine Holdings Limited.

FLIR is a registered trademark of FLIR Systems, Inc. and/or its subsidiaries.

All other trademarks, trade names, or company names referenced herein are used for identification only and are the property of their respective owners.

This product is protected by patents, design patents, patents pending, or design patents pending.

Fair Use Statement

You may print no more than three copies of this manual for your own use. You may not make any further copies or distribute or use the manual in any other way including without limitation exploiting the manual commercially or giving or selling copies to third parties.

Contents

Chapter 1 Important information

Certified Installation
Water ingress
Disclaimer
EMC installation guidelines
Suppression ferrites
Connections to other equipment
Declaration of conformity
Product disposal
Warranty registration
IMO and SOLAS
Technical accuracy

Chapter 2 Document and product information

2.1 Document information
2.2 Product overview

Chapter 3 Planning the installation

3.1 Installation checklist
3.2 Parts supplied
3.3 Required additional components
3.4 Compatible multifunction displays
3.5 Compatible autopilot systems
3.6 Software updates
3.7 Tools required
3.8 Typical systems
3.9 Warnings and cautions
3.10 General location requirements
3.11 Product dimensions

Chapter 4 Cables and connections

4.1 General cabling guidance
4.2 Connections overview
4.3 Power connection
4.4 Data and control connections

Chapter 5 Mounting

5.1 Mounting the unit

Chapter 6 System checks and troubleshooting

6.1 Initial power on test
6.2 Further information
6.3 Troubleshooting

Chapter 7 Maintenance

7.1 Routine checks
7.2 Unit cleaning instructions

Chapter 8 Technical support

8.1 Raymarine customer support
8.2 Viewing product information

Chapter 9 Technical specification

9.1 Technical specification

Chapter 10 Spares and accessories

10.1 Spares and accessories
10.2 SeaTalk^{ng} cables and accessories

Appendix A Supported messages

Chapter 1: Important information

Certified Installation

Raymarine recommends certified installation by a Raymarine approved installer. A certified installation qualifies for enhanced product warranty benefits. Contact your Raymarine dealer for further details, and refer to the separate warranty document packed with your product.



Warning: Product installation and operation

This product must be installed and operated in accordance with the instructions provided. Failure to do so could result in personal injury, damage to your vessel and/or poor product performance.



Warning: Product grounding

Before applying power to this product, ensure it has been correctly grounded, in accordance with the instructions in this guide.



Warning: Positive ground systems

Do not connect this unit to a system which has positive grounding.



Warning: Power supply voltage

Connecting this product to a voltage supply greater than the specified maximum rating may cause permanent damage to the unit. Refer to the *Technical specification* section for voltage rating.



Warning: Switch off power supply

Ensure the vessel's power supply is switched OFF before starting to install this product. Do NOT connect or disconnect equipment with the power switched on, unless instructed in this document.

Caution: Power supply protection

When installing this product ensure the power source is adequately protected by means of a suitably-rated fuse or automatic circuit breaker.

Caution: Service and maintenance

This product contains no user serviceable components. Please refer all maintenance and repair to authorized Raymarine dealers. Unauthorized repair may affect your warranty.

Water ingress

Water ingress disclaimer

Although the waterproof rating capacity of this product meets the stated IPX standard (refer to the product's *Technical Specification*), water intrusion and subsequent equipment failure may occur if the product is subjected to commercial high-pressure washing. Raymarine will not warrant products subjected to high-pressure washing.

Disclaimer

Raymarine does not warrant that this product is error-free or that it is compatible with products manufactured by any person or entity other than Raymarine.

Important information

Raymarine is not responsible for damages or injuries caused by your use or inability to use the product, by the interaction of the product with products manufactured by others, or by errors in information utilized by the product supplied by third parties.

EMC installation guidelines

Raymarine equipment and accessories conform to the appropriate Electromagnetic Compatibility (EMC) regulations, to minimize electromagnetic interference between equipment and minimize the effect such interference could have on the performance of your system

Correct installation is required to ensure that EMC performance is not compromised.

For **optimum** EMC performance we recommend that wherever possible:

- Raymarine equipment and cables connected to it are:
 - At least 1 m (3 ft) from any equipment transmitting or cables carrying radio signals e.g. VHF radios, cables and antennas. In the case of SSB radios, the distance should be increased to 7 ft (2 m).
 - More than 2 m (7 ft) from the path of a radar beam. A radar beam can normally be assumed to spread 20 degrees above and below the radiating element.
- The product is supplied from a separate battery from that used for engine start. This is important to prevent erratic behavior and data loss which can occur if the engine start does not have a separate battery.
- Raymarine specified cables are used.
- Cables are not cut or extended, unless doing so is detailed in the installation manual.

Note: Where constraints on the installation prevent any of the above recommendations, always ensure the maximum possible separation between different items of electrical equipment, to provide the best conditions for EMC performance throughout the installation

Suppression ferrites

Raymarine cables may be fitted with suppression ferrites. These are important for correct EMC performance. If a ferrite has to be removed for any purpose (e.g. installation or maintenance, it must be replaced in the original position before the product is used.

Use only ferrites of the correct type, supplied by Raymarine authorized dealers.

Where an installation requires multiple ferrites to be added to a cable, additional cable clips should be used to prevent stress on the connectors due to the extra weight of the cable.

Connections to other equipment

Requirement for ferrites on non-Raymarine cables

If your Raymarine equipment is to be connected to other equipment using a cable not supplied by Raymarine, a suppression ferrite **MUST** always be attached to the cable near the Raymarine unit.

Declaration of conformity

Raymarine UK Ltd. declares that this product is compliant with the essential requirements of EMC directive 2004/108/EC.

Product disposal

Dispose of this product in accordance with the WEEE Directive.



The Waste Electrical and Electronic Equipment (WEEE Directive) requires the recycling of waste electrical and electronic equipment. Whilst the WEEE Directive does not apply to some Raymarine products, we support its policy and ask you to be aware of how to dispose of this product.

Warranty registration

It is important that you register your product to receive full warranty benefits. Your unit package includes a bar code label indicating the serial number of the unit. You will need this serial number when registering your product online. You should retain the label for future reference.

IMO and SOLAS

The equipment described within this document is intended for use on leisure marine boats and workboats not covered by International Maritime Organization (IMO) and Safety of Life at Sea (SOLAS) Carriage Regulations.

Technical accuracy

To the best of our knowledge, the information in this document was correct at the time it was produced. However, Raymarine cannot accept liability for any inaccuracies or omissions it may contain. In addition, our policy of continuous product improvement may change specifications without notice. As a result, Raymarine cannot accept liability for any differences between the product and this document. Please check the Raymarine website to ensure you have the most up-to-date version(s) of the documentation for your product.

Chapter 2: Document and product information

Chapter contents

- [2.1 Document information](#)
- [2.2 Product overview](#)

2.1 Document information

This document contains important information related to the installation of your Raymarine product.

The document includes information to help you:

- plan your installation and ensure you have all the necessary equipment;
- install and connect your product as part of a wider system of connected marine electronics;
- troubleshoot problems and obtain technical support if required.

Applicable products

This document is applicable to the following products:

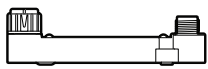
	Part number	Name	Description
	E70227	ECI-100	Engine & Control Interface

Document conventions

The following conventions are used throughout this document when referring to:

Type	Example	Convention
Procedures for performing specific tasks using a multifunction display.	Select Transducer Set-Up .	The term "Select" is used to refer to the action of selecting a menu option on a multifunction display, using the touchscreen or physical controls, depending on display variant.
Procedures for navigating menu hierarchies on a multifunction display.	Internal sonar module is turned off from the Fishfinder application menu: Menu > Set-up > Sounder Set-up > Internal Sounder .	Menu hierarchies are used in this document to provide a quick summary on how to access a particular function on the multifunction display.

Document illustrations

Your product may differ slightly from that shown in the illustrations in this document, depending on product variant and date of manufacture.

All images are provided for illustration purposes only.

Product documentation

The following documentation is applicable to your product:

Description	Part number
ECI-100 Installation instructions Installation of an ECI-100 unit and connection to a wider system of marine electronics.	88026 / 87202
SeaTalk^{ng} Reference manual Details the planning and operation of systems based on the SeaTalk ^{ng} network.	81300
New a Series, c Series, e Series Installation and operation instructions Details the operation of the Data application and autopilot integration for New a Series, c Series, e Series multifunction displays.	81337
gS Series Installation and operation instructions Details the operation of the Data application and autopilot integration for gS Series multifunction displays.	81345

2.2 Product overview

The unit connects to a SeaTalk^{ng} backbone or SeaTalk^{ng} device and to an engine's controller area network (CAN bus). J1939 and NMEA 2000 engine and transmission data and steering control messages are converted and then transmitted on to the SeaTalk^{ng} network; Enabling engine data transmission and steering control.

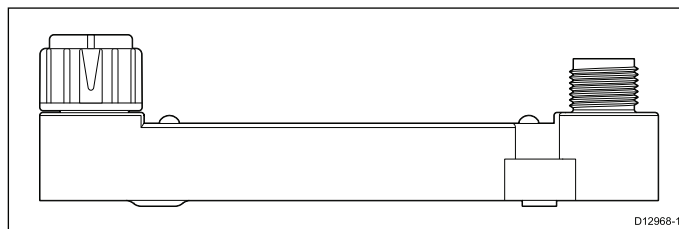

The ECI-100 can be used as an engine interface and a steering control interface at the same time.

The product includes the following features:

Engine interface

- Attaches directly to supported engines' CAN bus.
- Receives engine and transmission data, warnings, faults and alarms from the engine's CAN bus and transmits them on SeaTalk^{ng}

Steering control

- Attaches directly to supported 'drive-by-wire' steering control systems.
- Receives steering messages from a connected EV2 Evolution™ autopilot and transmits on the third party steering control system.
- Receives feedback from the steering control system and transmits on SeaTalk^{ng}.

The ECI-100 provides electrical Isolation between the third party CAN bus and SeaTalk^{ng}.

Supported engines / steering systems

The unit can be used to connect directly into engine CAN buses, which use the J1939 and / or NMEA 2000 standard and drive-by-wire steering control systems, used by many marine engine manufacturers including:

Supported engines

- Volvo Penta IPS
- Yamaha Marine Command Link Plus
- Other inboard, outboard and stern drive propulsion systems which use standard J1939 or NMEA 2000 protocols

Supported drive-by-wire steering systems

- Volvo Penta IPS
- Volvo Penta Aquamatic joystick control
- Yamaha Helm Master

Note: For systems containing more than 2 steering engines refer to the Raymarine website for compatibility information.

Chapter 3: Planning the installation

Chapter contents

- 3.1 Installation checklist
- 3.2 Parts supplied
- 3.3 Required additional components
- 3.4 Compatible multifunction displays
- 3.5 Compatible autopilot systems
- 3.6 Software updates
- 3.7 Tools required
- 3.8 Typical systems
- 3.9 Warnings and cautions
- 3.10 General location requirements
- 3.11 Product dimensions

3.1 Installation checklist

Installation includes the following activities:

Installation Task	
1	Plan your system.
2	Obtain all required equipment and tools.
3	Site all equipment.
4	Route all cables.
5	Drill cable and mounting holes.
6	Make all connections into equipment.
7	Secure all equipment in place.
8	Power on and test the system.



Schematic diagram

A schematic diagram is an essential part of planning any installation. It is also useful for any future additions or maintenance of the system. The diagram should include:

- Location of all components.
- Connectors, cable types, routes and lengths.

3.2 Parts supplied

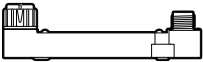
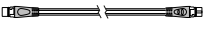
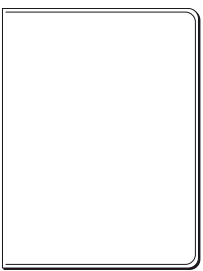
The following items are supplied with your product.

Item	Description	Quantity
	ECI-100 (Engine & Control Interface)	1
	400 mm (1.3 ft) SeaTalk ^{ng} spur cable (A06038)	1
	Document pack	1
	Mounting screws	2

3.3 Required additional components

This product forms part of a system of electronics and requires the following additional components for full operation.

- Engine specific adaptor cables are required to connect your unit to the engine(s) CAN bus. Refer to [Chapter 10 Spares and accessories](#) for suitable adaptor cables.
- To enable steering control a compatible Raymarine autopilot is required. Refer to [3.5 Compatible autopilot systems](#) for a list of compatible products.
- To display engine data a compatible Raymarine multifunction display is required. Refer to [3.4 Compatible multifunction displays](#) for a list of compatible products.

3.4 Compatible multifunction displays

This product is compatible with the following Raymarine multifunction displays.

- New a Series, New c Series, New e Series.
- gS Series.

Multifunction display software requirements

The operation of this product requires that your Raymarine multifunction display is running software version 8 or later.

3.5 Compatible autopilot systems

For steering control this product is compatible with the following Raymarine autopilots.

- EV2 — Evolution™ autopilot

3.6 Software updates

The software running on the product can be updated.

- Raymarine periodically releases software updates to improve product performance and add new features.
- You can update the software for your product using a connected and compatible multifunction display.
- Refer to raymarine for the latest software updates and the software update procedure for your product.
- If in doubt as to the correct procedure for updating your product software, refer to your dealer or Raymarine technical support.

Caution: Downloading software updates

The software update process is carried out at your own risk. Before initiating the update process ensure you have backed up any important files.

Ensure that the unit has a reliable power supply and that the update process is not interrupted.

Damage caused by incomplete updates are not covered by Raymarine warranty.

By downloading the software update package, you agree to these terms.

3.7 Tools required

Product installation requires the following tools:

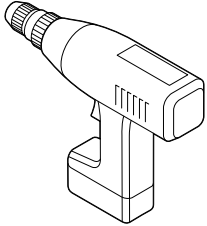
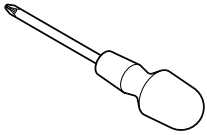
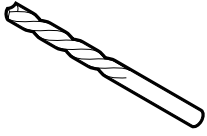
Item	Description	Quantity
	Power drill	1
	Pozidrive screwdriver	1
	Drill bit of appropriate size*	1

Note: * The appropriate drill bit size is dependent on the thickness and material of the mounting surface.

3.8 Typical systems

Important: Do NOT connect 2 or more ECI units to the same engine CAN bus.

Example: basic system — engine interface only

In the example below the unit is used as an engine interface only, the unit will interface with all engines on the same CAN bus. In this configuration the unit cannot control the vessel's steering system.

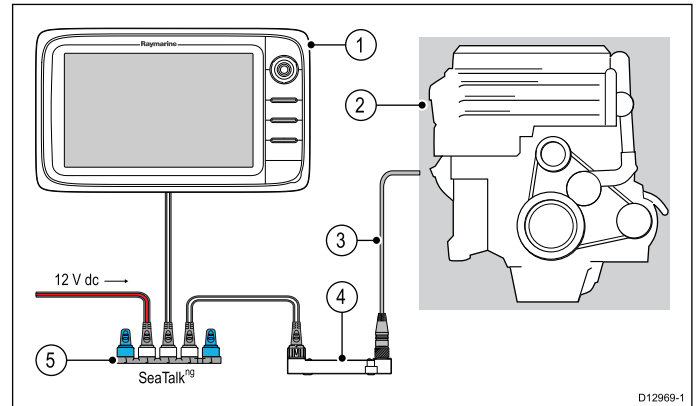

Note: The illustration above shows the various products that can be connected in a typical system. For information on how to connect the products, refer to the [Chapter 4 Cables and connections](#) section. For information on available cables and accessories, refer to the [Chapter 10 Spares and accessories](#) section.

Item	Description
1	Multifunction display
2	Vessel engine(s) (Connection to engine's CAN bus)
3	Engine-specific adaptor cable
4	ECI unit
5	SeaTalk ^{ng} 5-way block

Example: Independent engine CAN bus networks

On a multi-engine vessel that has dedicated CAN bus networks for each engine, then 1 unit per network is required.

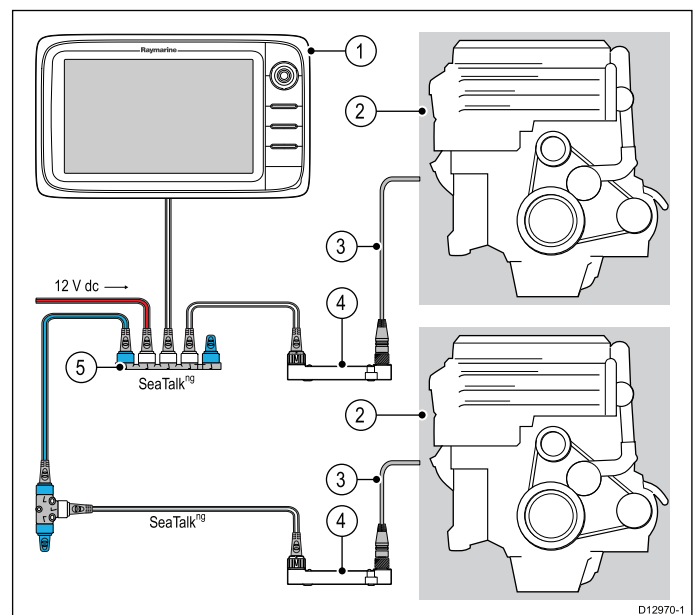

Note: The illustration above shows the various products that can be connected in a typical system. For information on how to connect the products, refer to the [Chapter 4 Cables and connections](#) section. For information on available cables and accessories, refer to the [Chapter 10 Spares and accessories](#) section.

Item	Description
1	Multifunction display
2	Vessel engines (Connection to engine's CAN bus)
3	Engine specific adaptor cables
4	ECI units
5	SeaTalk ^{ng} 5-way block

3.9 Warnings and cautions

Important: Before proceeding, ensure that you have read and understood the warnings and cautions provided in the [Chapter 1 Important information](#) section of this document.

Example: expanded system

In the example below the unit is used as both engine interface and steering control interface simultaneously.

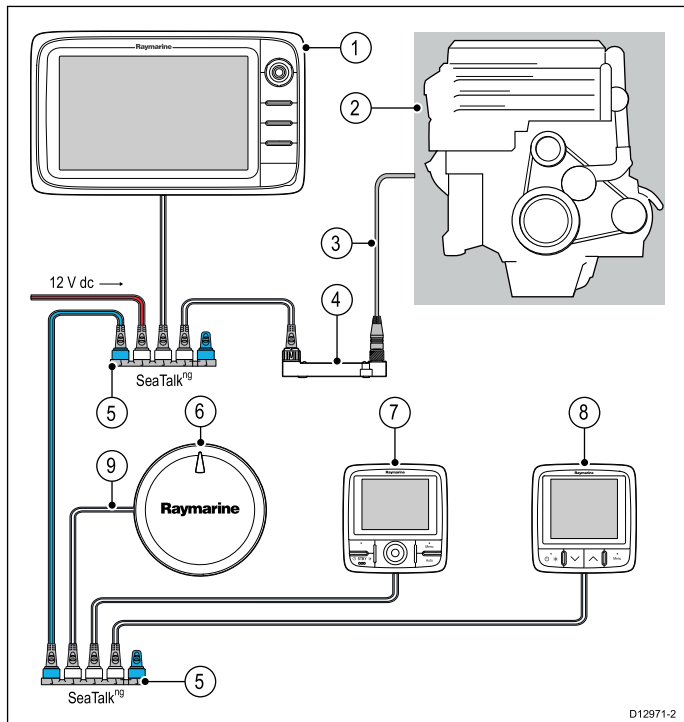

Note: The illustration above shows the various products that can be connected in a typical system. For information on how to connect the products, refer to the [Chapter 4 Cables and connections](#) section. For information on available cables and accessories, refer to the [Chapter 10 Spares and accessories](#) section.

Item	Description
1	Multifunction display
2	Vessel engine(s) and steering (Connection to engine CAN bus)
3	Engine-specific adaptor cable
4	ECI unit
5	SeaTalk ^{ng} 5-way block
6	EV2 — Evolution™ autopilot
7	SeaTalk ^{ng} Pilot control head
8	SeaTalk ^{ng} instrument display
9	SeaTalk ^{ng} spur cable connection between the SeaTalk ^{ng} bus and the EV2's SeaTalk ^{ng} connector.

3.10 General location requirements

Important considerations when choosing a suitable location for your product.

This product is suitable for mounting below decks.

The product should be mounted where it will be:

- protected from physical damage and excessive vibration.
- well ventilated and away from heat sources.

When choosing a location for the product, consider the following points to ensure reliable and trouble-free operation:

- **Access** — there must be sufficient space to enable cable connections to the product, avoiding tight bends in the cable.
- **Diagnostics** — the product must be mounted in a location where the diagnostics LED is easily visible.

Note: Not all products include a diagnostics LED. Refer to the [Chapter 6 System checks and troubleshooting](#) for more information.

- **Electrical interference** — the product should be mounted far enough away from any equipment that may cause interference such as motors, generators and radio transmitters / receivers.
- **Magnetic compass** — refer to the *Compass safe distance* section in this document for advice on maintaining a suitable distance between this product and any compasses on your vessel.
- **Power** — to keep cable runs to a minimum, the product must be located as close as possible to the vessel's dc power supply.
- **Mounting surface** — ensure the product is adequately supported on a secure surface. Refer to the weight information provided in the *Technical specification* for this product and ensure that the intended mounting surface is suitable for bearing the product weight. Do NOT mount units or cut holes in places which may damage the structure of the vessel.

Compass safe distance

To prevent potential interference with the vessel's magnetic compasses, ensure an adequate distance is maintained from the product.

When choosing a suitable location for the product you should aim to maintain the maximum possible distance from any compasses. Typically this distance should be at least 1 m (3 ft) in all directions. However for some smaller vessels it may not be possible to locate the product this far away from a compass. In this situation, when choosing the installation location for your product, ensure that the compass is not affected by the product when it is in a powered state.

3.11 Product dimensions

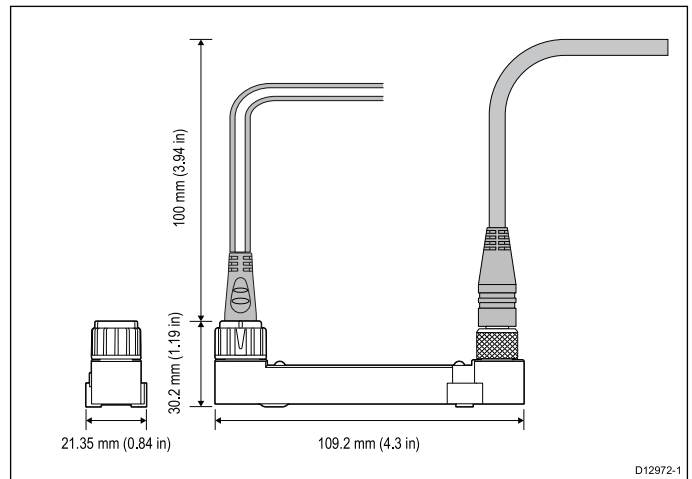

Chapter 4: Cables and connections

Chapter contents

- [4.1 General cabling guidance](#)
- [4.2 Connections overview](#)
- [4.3 Power connection](#)
- [4.4 Data and control connections](#)

4.1 General cabling guidance

Cable types and length

It is important to use cables of the appropriate type and length

- Unless otherwise stated use only standard cables of the correct type, supplied by Raymarine.
- Ensure that any non-Raymarine cables are of the correct quality and gauge. For example, longer power cable runs may require larger wire gauges to minimize voltage drop along the run.

Routing cables

Cables must be routed correctly, to maximize performance and prolong cable life.

- Do NOT bend cables excessively. Wherever possible, ensure a minimum bend diameter of 200 mm (8 in) / minimum bend radius of 100 mm (4 in).

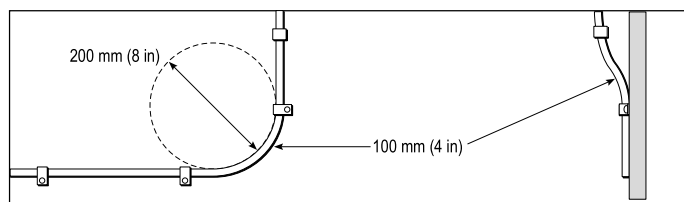

- Protect all cables from physical damage and exposure to heat. Use trunking or conduit where possible. Do NOT run cables through bilges or doorways, or close to moving or hot objects.
- Secure cables in place using tie-wraps or lacing twine. Coil any extra cable and tie it out of the way.
- Where a cable passes through an exposed bulkhead or deckhead, use a suitable watertight feed-through.
- Do NOT run cables near to engines or fluorescent lights.

Always route data cables as far away as possible from:

- other equipment and cables,
- high current carrying ac and dc power lines,
- antennae.

Strain relief

Ensure adequate strain relief is provided. Protect connectors from strain and ensure they will not pull out under extreme sea conditions.

Circuit isolation

Appropriate circuit isolation is required for installations using both AC and DC current:

- Always use isolating transformers or a separate power-inverter to run PC's, processors, displays and other sensitive electronic instruments or devices.
- Always use an isolating transformer with Weather FAX audio cables.
- Always use an isolated power supply when using a 3rd party audio amplifier.
- Always use an RS232/NMEA converter with optical isolation on the signal lines.
- Always make sure that PC's or other sensitive electronic devices have a dedicated power circuit.

Cable shielding

Ensure that all data cables are properly shielded that the cable shielding is intact (e.g. hasn't been scraped off by being squeezed through a tight area).

4.2 Connections overview

Use the following information to help you identify the connections on your product.

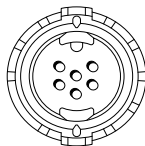
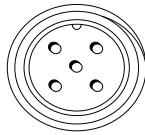
Connector	Connector	Connects to:	Suitable cables
	SeaTalk ^{ng}	SeaTalk ^{ng} using the supplied spur cable.	SeaTalk ^{ng} spur cables. Refer to Chapter 10 Spares and accessories .
	DeviceNet	Engine CAN bus.	Engine specific DeviceNet adaptor cable. Refer to Chapter 10 Spares and accessories .

Ensure that the DeviceNet connector's dust cap is removed before trying to make connections.

Making connections

Follow the steps below to connect the cable(s) to your product.

1. Ensure that the vessel's power supply is switched off.
2. Ensure that the device being connected to the unit has been installed in accordance with the installation instructions supplied with that device.
3. Ensuring correct orientation, push the cable connector fully onto the corresponding connector on the unit.
4. Turn the locking collar clockwise to secure the cable.

4.3 Power connection

Both connections need power to be supplied from each network i.e. The SeaTalk^{ng} connection is powered by the SeaTalk^{ng} backbone or Seataalk^{ng} device and the engine (DeviceNet) connection is powered from the engine's CAN bus network.

The information in this section relates to powering the SeaTalk^{ng} network. Power will already be available on your engines CAN bus to power the DeviceNet connection.

Please refer to the *Raymarine SeaTalk^{ng} Reference manual (81300)* for further information on SeaTalk^{ng} networks.

Power cable extension

The product is supplied with a power cable, which can be extended if required.

- The power cable for each unit in your system should be run as a separate, single length of 2-wire cable from the unit to the vessel's battery or distribution panel.
- Raymarine recommends a **minimum** wire gauge of 18AWG (0.82 mm²) for any length of cable extension.
- Regardless of the length of the cable extension, any cable used should be capable of achieving a **minimum** voltage at the unit of 10.8 V with a fully flat battery at 11 V.

Power distribution

Raymarine recommends that all power connections are made via a distribution panel.

- All equipment must be powered from a breaker or switch, with appropriate circuit protection.
- Refer to the *Breakers, fuses and circuit protection* section for specific fuse and thermal breaker ratings for this product.

Breakers, fuses and circuit protection

It is recommended that you fit a thermal breaker or fuse at the distribution panel.

Thermal breaker rating
5 A (if only connecting one device)

Note: The suitable fuse rating for the thermal breaker is dependent on the number of devices you are connecting. If in doubt consult an authorized Raymarine dealer.

Sharing a breaker

Where more than 1 piece of equipment shares a breaker you must provide protection for the individual circuits. E.g. by connecting an in-line fuse for each power circuit.

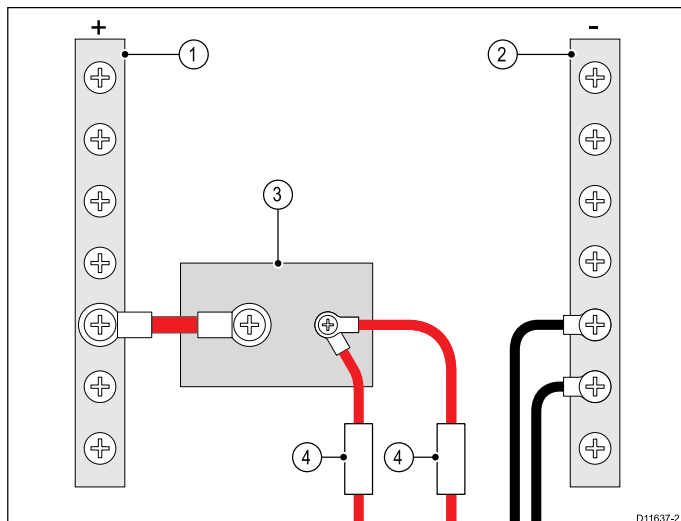

1	Positive (+) bar
2	Negative (-) bar

Cables and connections

3	Circuit breaker
4	Fuse

Where possible, connect individual items of equipment to individual circuit breakers. Where this is not possible, use individual in-line fuses to provide the necessary protection.

Warning: Product grounding

Before applying power to this product, ensure it has been correctly grounded, in accordance with the instructions in this guide.

Grounding — Dedicated drain wire

The power cable supplied with this product includes a dedicated shield (drain) wire for connection to a vessel's RF ground point.

It is important that an effective RF ground is connected to the system. A single ground point should be used for all equipment. The unit can be grounded by connecting the shield (drain) wire of the power cable to the vessel's RF ground point. On vessels without an RF ground system the shield (drain) wire should be connected directly to the negative battery terminal.

The dc power system should be either:

- Negative grounded, with the negative battery terminal connected to the vessel's ground.
- Floating, with neither battery terminal connected to the vessel's ground

Warning: Positive ground systems

Do not connect this unit to a system which has positive grounding.

4.4 Data and control connections

The illustrations below are examples of how the unit can be connected to SeaTalk^{ng} and a compatible engine's CAN bus to enable engine data transmission and steering control.

Important: Raymarine does not recommend that the ECI-100 is used on the same CAN bus as other 3rd party gateway products. The ECI-100 should be used to replace existing gateway products in your system.

Note: The illustrations below are examples only. Engine CAN bus connections are made using either a 'Y' loom cable, CAN bus hub or a trailing lead. The connection method will differ depending on engine manufacturer. The SeaTalk^{ng} connection remains the same regardless of engine manufacturer.

For details on compatible engines and steering systems please refer to the [Supported engines / steering systems](#) section.

Single engine CAN bus 'Y' loom connection

Depending on engine manufacturer the unit may be connected using a 'Y' loom cable as shown below. This connection method should normally be used when a CAN bus hub is not present.

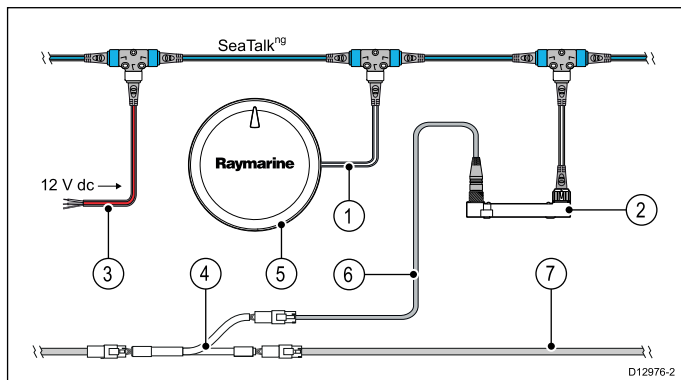

Item	Description
1	SeaTalk ^{ng} spur cable connection between the SeaTalk ^{ng} backbone and the EV2's SeaTalk ^{ng} connector.
2	ECI-100 unit
3	SeaTalk ^{ng} network power supply (12 V dc)
4	Y Loom cable
5	EV2 — Evolution™ autopilot
6	Engine-specific adaptor cable
7	Engine CAN bus

Single engine CAN bus multi-link hub connection

Where available the unit should be connected using the CAN bus hub.

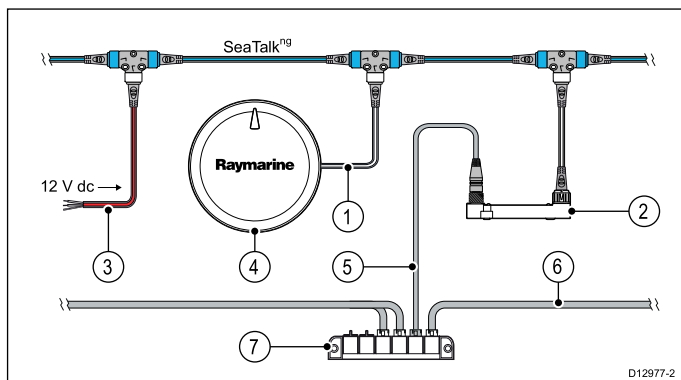

Item	Description
1	SeaTalk ^{ng} spur cable connection between the SeaTalk ^{ng} backbone and the EV2's SeaTalk ^{ng} connector.
2	ECI-100 unit
3	SeaTalk ^{ng} network power supply (12 V dc)

Item	Description
4	EV2 — Evolution™ autopilot
5	Engine-specific adaptor cable
6	Engine CAN bus
7	CAN bus hub

Multi CAN bus connection

On vessels which have a dedicated CAN bus for each engine, 1 unit is required per CAN bus.

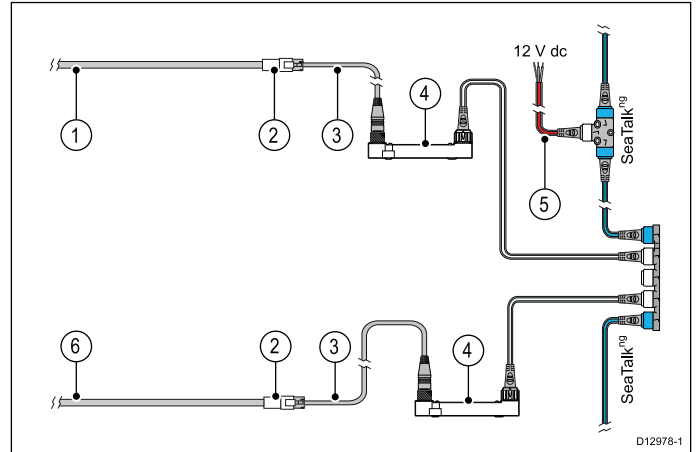

Item	Description
1	Engine 1 CAN bus
2	Trailing lead
3	Engine-specific adaptor cable.
4	ECI-100
5	SeaTalk ^{ng} network power supply (12 V dc)
6	Engine 2 CAN bus

For details on available network hardware and cables refer to [Chapter 10 Spares and accessories](#).

If your engine data appears in the wrong order on the engine data pages of your multifunction display you can correct this by running the engine identification wizard.

Chapter 5: Mounting

Chapter contents

- [5.1 Mounting the unit](#)

5.1 Mounting the unit

The ECI is designed to be surface mounted.

Before mounting the unit ensure that you have:

- Identified the routes that the cables will take.

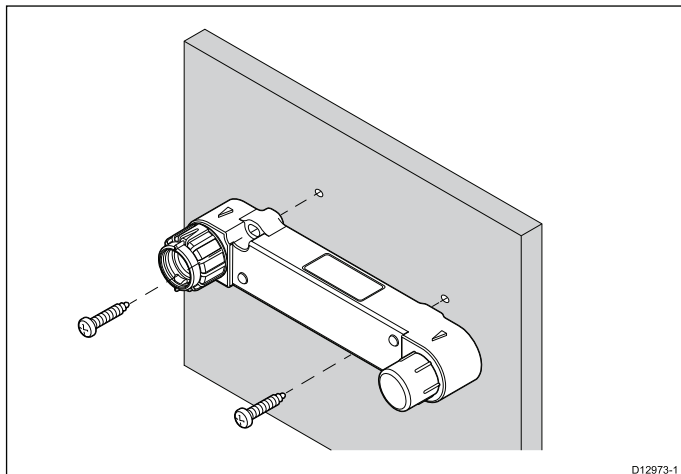

1. Switch off the vessel's power supply.
2. Check the selected location for the unit, a clear, flat area is required, which is safe to have screws fitted to.
3. Position the converter against the selected location and mark the surface through the converter's mounting holes.
4. Using an appropriate size drill bit, drill 2 holes at the marked locations.
5. Position the converter so that the mounting holes of the unit line up with the drilled holes in the mounting surface.
6. Using the fixings provided secure the converter to the mounting surface. Do NOT overtighten the fixings.
7. Connect the SeaTalk^{ng} spur cable and the DeviceNet adaptor cable to the unit.
8. Ensure the CAN bus connector of the DeviceNet adaptor cable is plugged into the relevant point on the engine's CAN bus.
9. Switch the vessel's power supply back on and check system.

Chapter 6: System checks and troubleshooting

Chapter contents

- [6.1 Initial power on test](#)
- [6.2 Further information](#)
- [6.3 Troubleshooting](#)

6.1 Initial power on test

Once your product is fully connected and installed, perform an initial power on test to verify correct operation.

1. Switch on the vessel's power supply.
2. Look at the diagnostics LEDs.
 - During power up the LEDs will be illuminated red (power up usually takes approximately 6 seconds).
 - During normal operation the LED should flash green once every 15 seconds.
3. If the LED flashes in a different sequence, refer to the LED Diagnostics section for details.

6.2 Further information

For detailed operating instructions, refer to the handbook that accompanies your multifunction display.

6.3 Troubleshooting

The troubleshooting information provides possible causes and corrective action required for common problems associated with marine electronics installations.

All Raymarine products are, prior to packing and shipping, subjected to comprehensive test and quality assurance programs. However, if you experience problems with the operation of your product this section will help you to diagnose and correct problems in order to restore normal operation.

If after referring to this section you are still having problems with your unit, please contact Raymarine Technical Support for further advice.



System data troubleshooting

Aspects of the installation can cause problems with the data shared between connected equipment. Such problems, their possible causes and solutions are described here.

Problem	Possible causes	Possible solutions
Instrument, engine or other system data is unavailable at all displays.	Data is not being received at the display.	Check the data bus (e.g. SeaTalk ^{ng}) wiring and connections.
		Check the overall integrity of the data bus (e.g. SeaTalk ^{ng}) wiring.
		If available refer to the reference guide for the data bus (e.g. SeaTalk ^{ng} reference manual).
	Data source (e.g. ST70 instrument or engine interface) is not operating.	Check the source of the missing data (e.g. ST70 instrument or engine interface).
		Check the power to the SeaTalk bus.
		Refer to the manufacturer's handbook for the equipment in question.
Software mismatch between equipment may prevent communication.	Contact Raymarine technical support.	
Instrument or other system data is missing from some but not all displays.	Network problem.	Check that all required equipment is connected to the network.
		Check the status of the Raymarine network Switch.
		Check that SeaTalk ^{hs} / RayNet cables are free from damage.
	Software mismatch between equipment may prevent communication.	Contact Raymarine technical support.

LED indications

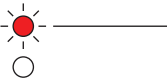
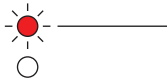
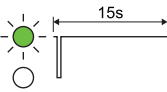
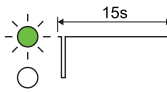
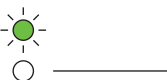
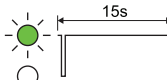
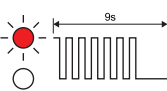
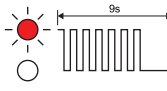
This product contains 2 diagnostic LEDs, one for the SeaTalk^{ng} connection and one for the engine CAN bus connection. The LEDs for this product flash (blink) in set sequences which provides information on the current status of the unit for diagnostics and troubleshooting purposes.

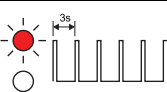
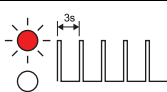
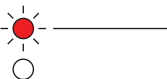
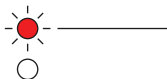
LED color	SeaTalk ^{ng} LED code	Engine CAN bus LED code	State	User action
Red			Powering up	None (normal power up takes approximately 6 seconds.)
Green			Normal operation	None
Green			DeviceNet powered on, SeaTalk ^{ng} powered off	Power up SeaTalk ^{ng} network.
Red			Network connected but no traffic (no message received in more than 5 seconds.)	
Red			SeaTalk ^{ng} powered on, DeviceNet Off.	
Red			General error (Device connected wrong way round)	Swap over SeaTalk ^{ng} and DeviceNet connections
Red			Software download in progress (longer than 6 seconds.)	Wait for download to complete — Multifunction display will indicate when software download is completed.

Note: If any other LED sequence other than described above is seen and persists please contact Raymarine technical support.

Chapter 7: Maintenance

Chapter contents

- [7.1 Routine checks](#)
- [7.2 Unit cleaning instructions](#)

7.1 Routine checks

The following periodic checks should be made:

- Examine cables for signs of damage, such as chafing, cuts or nicks.
- Check that the cable connectors are firmly attached and that their locking mechanisms are properly engaged.

Note: Cable checks should be carried out with the power supply switched off.

7.2 Unit cleaning instructions

The unit does not require regular cleaning. However, if you find it necessary to clean the unit, please follow the steps below:

1. Ensure power is switched off.
2. Wipe unit clean with a damp cloth.
3. If necessary, use a mild detergent solution to remove grease marks.

Chapter 8: Technical support

Chapter contents

- [8.1 Raymarine customer support](#)
- [8.2 Viewing product information](#)

8.1 Raymarine customer support

Raymarine provides a comprehensive customer support service. You can contact customer support through the Raymarine website, telephone and e-mail. If you are unable to resolve a problem, please use any of these facilities to obtain additional help.

Web support

This contains Frequently Asked Questions, servicing information, e-mail access to the Raymarine Technical Support Department and details of worldwide Raymarine agents.

Product information

If you need to request service, please have the following information to hand:

- Product name.
- Product identity.
- Serial number.
- Software application version.
- System diagrams.

You can obtain this product information using the menus within your product.

8.2 Viewing product information

You can view information about your unit from the **Diagnostics** menu on a compatible multifunction display. This option displays information such as product serial number and software version.

With the Homescreen displayed:

1. Select **Set-up**.
2. Select **Maintenance**.
3. Select **Diagnostics**.
4. Select the **Select Device** option.
A list of connected devices is displayed.
5. Select the product for which you want to view information. Alternatively, select **Show All Data** to display information for all connected products.

Chapter 9: Technical specification

Chapter contents

- [9.1 Technical specification](#)

9.1 Technical specification

Physical specification

Dimensions	<ul style="list-style-type: none">• Length: 109.2 mm (4.3 in)• Height: 30.2 mm (1.19 in)• Width: 21.35 mm (0.84 in)
Weight	43 g (1.52 oz)

Power specification

	SeaTalk ^{ng}	Engine CAN bus (DeviceNet)
Nominal supply voltage	12 V dc	12 to 24 V dc
Operating voltage range	10.8 V to 16 V dc	10.8 V dc to 31.2 V dc
Current	12 mA	<ul style="list-style-type: none">• 12V — 12.5 mA• 24V — 11 mA
Load Equivalency Number (LEN)	1	N/A

Environmental specification

Operating temperature	-20°C to +55°C (+4°F to +131°F)
Storage temperature	-30°C to +70°C (-22°F to +158°F)
Relative humidity	95%
Waterproof rating	IPX6 and IPX7

Conformance specification

Conformance	<ul style="list-style-type: none">• EN 60945:2002• EMC Directive 2004/108/EC• Australia and New Zealand: C-Tick, Compliance Level 2
-------------	---

Chapter 10: Spares and accessories

Chapter contents

- [10.1 Spares and accessories](#)
- [10.2 SeaTalk^{ng} cables and accessories](#)

10.1 Spares and accessories

Engine specific adaptor cables

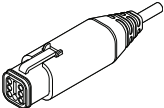
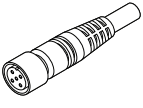
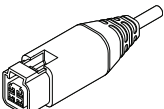
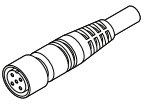
Description	Engine connector	ECI connector	Part number
Volvo EVC link cable – 1 m (3.3 ft)			E70240
Yamaha Command Link Plus cable – 1 m (3.3 ft)			E70242

Y Loom cables

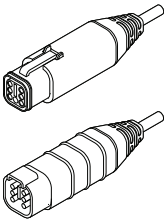
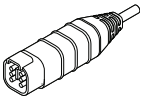
Description	Engine connectors (black)	Adaptor cable connector (Gray)	Part number
Volvo Y-Loom cable – 1 m (3.3 ft) / 500 mm (1.5 ft)			E70241

10.2 SeaTalk^{ng} cables and accessories

SeaTalk^{ng} cables and accessories for use with compatible products.

Description	Part No	Notes
SeaTalk ^{ng} starter kit	T70134	Includes: <ul style="list-style-type: none"> • 1 x 5 Way connector (A06064) • 2 x Backbone terminator (A06031) • 1 x 3 m (9.8 ft) spur cable (A06040) • 1 x Power cable (A06049)
SeaTalk ^{ng} Backbone Kit	A25062	Includes: <ul style="list-style-type: none"> • 2 x 5 m (16.4 ft) Backbone cable (A06036) • 1 x 20 m (65.6 ft) Backbone cable (A06037) • 4 x T-piece (A06028) • 2 x Backbone terminator (A06031) • 1 x Power cable (A06049)
SeaTalk ^{ng} 0.4 m (1.3 ft) spur	A06038	
SeaTalk ^{ng} 1 m (3.3 ft) spur	A06039	
SeaTalk ^{ng} 3 m (9.8 ft) spur	A06040	
SeaTalk ^{ng} 5 m (16.4 ft) spur	A06041	
SeaTalk ^{ng} 0.4 m (1.3 ft) elbow spur	A06042	
SeaTalk ^{ng} 0.4 m (1.3 ft) backbone	A06033	
SeaTalk ^{ng} 1 m (3.3 ft) backbone	A06034	
SeaTalk ^{ng} 3 m (9.8 ft) backbone	A06035	
SeaTalk ^{ng} 5 m (16.4 ft) backbone	A06036	
SeaTalk ^{ng} 9 m (29.5 ft) backbone	A06068	
SeaTalk ^{ng} 20 m (65.6 ft) backbone	A06037	
SeaTalk ^{ng} to bare ends 1 m (3.3 ft) spur	A06043	
SeaTalk ^{ng} to bare ends 3 m (9.8 ft) spur	A06044	
SeaTalk ^{ng} Power cable	A06049	
SeaTalk ^{ng} Terminator	A06031	
SeaTalk ^{ng} T-piece	A06028	Provides 1 x spur connection
SeaTalk ^{ng} 5-way connector	A06064	Provides 3 x spur connections
SeaTalk ^{ng} backbone extender	A06030	
SeaTalk to SeaTalk ^{ng} converter kit	E22158	Allows the connection of SeaTalk devices to a SeaTalk ^{ng} system.

Description	Part No	Notes
SeaTalk ^{ng} Inline terminator	A80001	Provides direct connection of a spur cable to the end of a backbone cable. No T-piece required.
SeaTalk ^{ng} Blanking plug	A06032	
ACU / SPX SeaTalk ^{ng} spur cable 0.3 m (1.0 ft)	R12112	Connects an SPX course computer or an ACU to a SeaTalk ^{ng} backbone.
SeaTalk (3 pin) to SeaTalk ^{ng} adaptor cable 0.4 m (1.3 ft)	A06047	
SeaTalk to SeaTalk ^{ng} spur 1 m (3.3 ft) spur	A22164	
SeaTalk2 (5 pin) to SeaTalk ^{ng} adaptor cable 0.4 m (1.3 ft)	A06048	
DeviceNet adaptor cable (Female)	A06045	Allows the connection of NMEA 2000 devices to a SeaTalk ^{ng} system.
DeviceNet adaptor cable (Male)	A06046	Allows the connection of NMEA 2000 devices to a SeaTalk ^{ng} system.
DeviceNet adaptor cable (Female) to bare ends.	E05026	Allows the connection of NMEA 2000 devices to a SeaTalk ^{ng} system.
DeviceNet adaptor cable (Male) to bare ends.	E05027	Allows the connection of NMEA 2000 devices to a SeaTalk ^{ng} system.

Appendix A Supported messages

The table below shows a list of the standard parameters and messages that the unit supports.

Standard J1939

Engine Parameter	PGN	SPN
Engine Speed	61444	190
Engine Oil Temperature	65262	175
Engine Temperature	65262	110
Engine Oil Pressure	65263	100
Engine Coolant Pressure	65263	109
Engine Fuel Pressure	65263	94
Engine Fuel Rate	65266	183
Boost Pressure	65270	102
Transmission Oil Pressure	65272	127
Transmission Oil Temperature	65272	177
Total Engine Hours	65253	247
Fuel Tank Level	65276	96
Alternator Potential	65271	167
Engine Percent Load	61443	92
Transmission Gear	61445	523

NMEA 2000

Engine Parameter	PGN
Engine Speed	127488
Engine Oil Temperature	127489
Engine Temperature	127489
Engine Oil Pressure	127489
Engine Coolant Pressure	127489
Engine Fuel Pressure	127489
Engine Fuel Rate	127489
Boost Pressure	127488
Transmission Oil Pressure	127493
Transmission Oil Temperature	127493
Total Engine Hours	127489
Fuel Tank Level	127505
Trip Fuel Used	127497
Alternator Potential	127489
Engine Percent Load	127489
Transmission Gear	127493