

RMK-10

INSTALLATION INSTRUCTIONS

English (en-US)

Date: 11-2016

Document number: 81367-1

© 2016 Raymarine UK Limited



Raymarine®

Trademark and patents notice

Raymarine, Tacktick, Clear Pulse, Truzoom, HSB, SeaTalk, SeaTalk^{hs}, SeaTalk^{ng}, Micronet, Raytech, Gear Up, Marine Shield, Seahawk, Autohelm, Automagic, and Visionality are registered or claimed trademarks of Raymarine Belgium.

FLIR, DownVision, SideVision, Dragonfly, Quantum, Instalert, Infrared Everywhere, and The World's Sixth Sense are registered or claimed trademarks of FLIR Systems, Inc.

All other trademarks, trade names, or company names referenced herein are used for identification only and are the property of their respective owners.

This product is protected by patents, design patents, patents pending, or design patents pending.

Fair Use Statement

You may print no more than three copies of this manual for your own use. You may not make any further copies or distribute or use the manual in any other way including without limitation exploiting the manual commercially or giving or selling copies to third parties.



Warning: Product installation and operation

- This product must be installed and operated in accordance with the instructions provided. Failure to do so could result in personal injury, damage to your vessel and/or poor product performance.
- Raymarine recommends certified installation by a Raymarine approved installer. A certified installation qualifies for enhanced product warranty benefits. Contact your Raymarine dealer for further details, and refer to the separate warranty document packed with your product.



Warning: Potential ignition source

This product is NOT approved for use in hazardous/flammable atmospheres. Do NOT install in a hazardous/flammable atmosphere (such as in an engine room or near fuel tanks).



Warning: Product grounding

Before applying power to this product, ensure it has been correctly grounded, in accordance with the instructions provided.



Warning: Positive ground systems

Do not connect this unit to a system which has positive grounding.



Warning: Switch off power supply

Ensure the vessel's power supply is switched OFF before starting to install this product. Do NOT connect or disconnect equipment with the power switched on, unless instructed in this document.

Caution: Power supply protection

When installing this product ensure the power source is adequately protected by means of a suitably-rated fuse or automatic circuit breaker.

Water ingress disclaimer

Although the waterproof rating capacity of this product meets the IPX6 standard, water intrusion and subsequent equipment failure may occur if the product is subjected to commercial high-pressure washing. Raymarine will not warrant products subjected to high-pressure washing.

Disclaimer

Raymarine does not warrant that this product is error-free or that it is compatible with products manufactured by any person or entity other than Raymarine.

Raymarine is not responsible for damages or injuries caused by your use or inability to use the product, by the interaction of the product with products manufactured by others, or by errors in information utilized by the product supplied by third parties.

EMC installation guidelines

Raymarine equipment and accessories conform to the appropriate Electromagnetic Compatibility (EMC) regulations, to minimize electromagnetic interference between equipment and minimize the effect such interference could have on the performance of your system

Correct installation is required to ensure that EMC performance is not compromised.

Note: In areas of extreme EMC interference, some slight interference may be noticed on the product. Where this occurs the product and the source of the interference should be separated by a greater distance.

For **optimum** EMC performance we recommend that wherever possible:

- Raymarine equipment and cables connected to it are:
 - At least 1 m (3 ft) from any equipment transmitting or cables carrying radio signals e.g. VHF radios, cables and antennas. In the case of SSB radios, the distance should be increased to 7 ft (2 m).
 - More than 2 m (7 ft) from the path of a radar beam. A radar beam can normally be assumed to spread 20 degrees above and below the radiating element.
- The product is supplied from a separate battery from that used for engine start. This is important to prevent erratic behavior and data loss which can occur if the engine start does not have a separate battery.
- Raymarine specified cables are used.
- Cables are not cut or extended, unless doing so is detailed in the installation manual.

Note: Where constraints on the installation prevent any of the above recommendations, always ensure the maximum possible separation between different items of electrical equipment, to provide the best conditions for EMC performance throughout the installation

Declaration of conformity

Raymarine UK Ltd. declares that this product is compliant with the essential requirements of EMC directive 2004/108/EC.

Product disposal

Dispose of this product in accordance with the WEEE Directive.

 The Waste Electrical and Electronic Equipment (WEEE) Directive requires the recycling of waste electrical and electronic equipment.

Warranty registration

It is important that you register your product to receive full warranty benefits. Your unit package includes a bar code label indicating the serial number of the unit. You will need this serial number when registering your product online. You should retain the label for future reference.

IMO and SOLAS

The equipment described within this document is intended for use on leisure marine boats and workboats NOT covered by International Maritime Organization (IMO) and Safety of Life at Sea (SOLAS) Carriage Regulations.

Technical accuracy

To the best of our knowledge, the information in this document was correct at the time it was produced. However, Raymarine cannot accept liability for any inaccuracies or omissions it may contain. In addition, our policy of continuous product improvement may change specifications without notice. As a result, Raymarine cannot accept liability for any differences between the product and this document.

Chapter 2: Document and product information

2.1 Document information

This document contains important information related to the installation of your Raymarine product.

The document includes information to help you:

- plan your installation and ensure you have all the necessary equipment;
- install and connect your product as part of a wider system of connected marine electronics;
- troubleshoot problems and obtain technical support if required.

Product documentation

The following documentation is applicable to your product:

Description	Part number
Installation and operation instructions	81367
RMK-10 Mounting template	87283

2.2 Product overview

The **RMK-10** is a Remote Keypad for Raymarine multifunction displays (MFD). The keypad is a class 1 PoE (Power Over Ethernet) device and can be powered either using a suitable network connection, that is providing PoE, or directly using the dedicated Alternate power connector. The keypad includes an internal buzzer that is used to repeat key press beeps and MFD alarms.

The keypad can be mounted in landscape or portrait orientation.

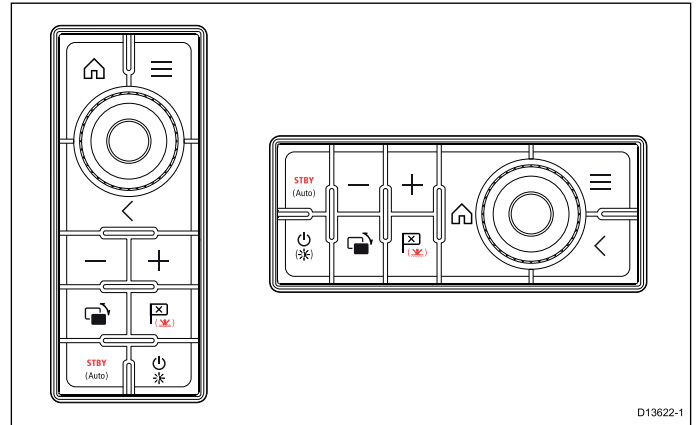

Part number	Description
A80438	RMK-10 — Portrait orientation When ordering A80438 only the portrait keypad mat is supplied.
T70293	RMK-10 — Landscape orientation When ordering T70293 both orientation keypad mats are supplied.

Compatibility

The **RMK-10** is compatible with the following LightHouse™ powered MFDs.

- a Series
- c Series
- e Series
- gS Series
- eS Series

MFDs require LightHouse™ software release 7 or later.

Chapter 3: Planning the installation

3.1 Installation checklist

Installation includes the following activities:

Installation Task	
1	Plan your system.
2	Obtain all required equipment and tools.
3	Site all equipment.
4	Route all cables.
5	Drill cable and mounting holes.
6	Make all connections into equipment.
7	Secure all equipment in place.
8	Power on and test the system.

Schematic diagram

A schematic diagram is an essential part of planning any installation. It is also useful for any future additions or maintenance of the system. The diagram should include:

- Location of all components.
- Connectors, cable types, routes and lengths.

3.2 Parts supplied

The parts supplied with the keypad are shown below.

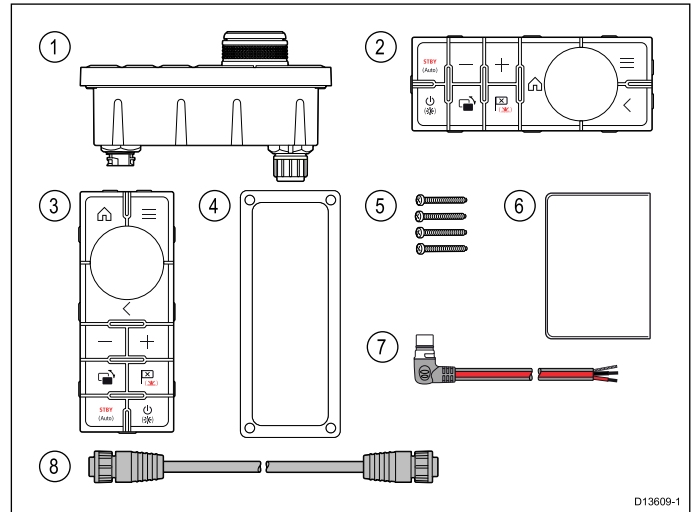

1. **RMK-10** keypad
 2. Landscape keypad mat
- Note:** The Landscape keypad mat is only supplied with **T70293**
3. Portrait keypad mat (supplied fitted to the unit)
 4. Mounting gasket
 5. 4 x mounting fixings
 6. Documentation pack
 7. Right angled power cable 2 m (6.6 ft.)
 8. RayNet network cable 2 m (6.6 ft.)

3.3 Software updates

The software running on the product can be updated.

- Raymarine periodically releases software updates to improve product performance and add new features.
- The software on many products can be updated using a connected and compatible multifunction display (MFD).

Important:

- To prevent potential software-related issues with your product, always follow the relevant update instructions carefully and in the sequence provided.
- If in doubt as to the correct procedure for updating your product software, refer to your dealer or Raymarine technical support.

Caution: Installing software updates

The software update process is carried out at your own risk. Before initiating the update process ensure you have backed up any important files.

Ensure that the unit has a reliable power supply and that the update process is not interrupted.

Damage caused by incomplete updates are not covered by Raymarine warranty.

By downloading the software update package, you agree to these terms.

3.4 Tools required

Product installation requires the following tools:

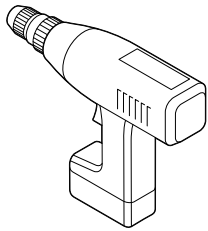
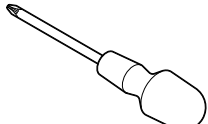
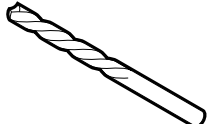
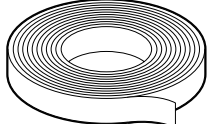
Item	Description	Quantity
	Power drill	1
	Pozidrive screwdriver	1
	Drill bit of appropriate size*	1
	Adhesive tape	1

Note: * The appropriate drill bit size is dependent on the thickness and material of the mounting surface.

3.5 General location requirements

Important considerations when choosing a suitable location for your product.

This product is suitable for mounting above or below decks.

The product should be mounted where it will be:

- protected from physical damage and excessive vibration.
- well ventilated and away from heat sources.
- away from any potential ignition source such as an engine room, near fuel tanks or a gas locker.

When choosing a location for the product, consider the following points to ensure reliable and trouble-free operation:

- **Access** — there must be sufficient space to enable cable connections to the product, avoiding tight bends in the cable.
- **Diagnostics** — the product must be mounted in a location where the diagnostics LED is easily visible.

Note: Not all products include a diagnostics LED. Refer to the [Chapter 7 System checks and troubleshooting](#) for more information.

- **Electrical interference** — the product should be mounted far enough away from any equipment that may cause interference such as motors, generators and radio transmitters / receivers.
- **Magnetic compass** — refer to the *Compass safe distance* section in this document for advice on maintaining a suitable distance between this product and any compasses on your vessel.
- **Power** — to keep cable runs to a minimum, the product must be located as close as possible to the vessel's dc power supply.
- **Mounting surface** — ensure the product is adequately supported on a secure surface. Refer to the weight information provided in the *Technical specification* for this product and ensure that the intended mounting surface is suitable for bearing the product weight. Do NOT mount units or cut holes in places which may damage the structure of the vessel.

3.6 Warnings and cautions

Important: Before proceeding, ensure that you have read and understood the warnings and cautions provided in the [Chapter 1 Important information](#) section of this document.

Product dimensions

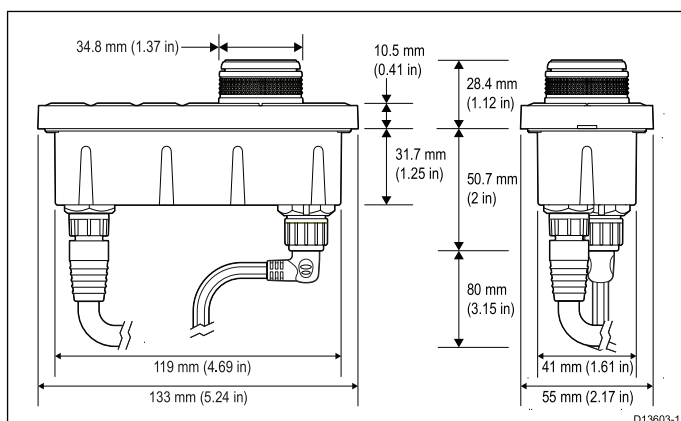

Chapter 4: Cables and connections

4.1 General cabling guidance

Cable types and length

It is important to use cables of the appropriate type and length

- Unless otherwise stated use only standard cables of the correct type, supplied by Raymarine.
- Ensure that any non-Raymarine cables are of the correct quality and gauge. For example, longer power cable runs may require larger wire gauges to minimize voltage drop along the run.

Routing cables

Cables must be routed correctly, to maximize performance and prolong cable life.

- Do NOT bend cables excessively. Wherever possible, ensure a minimum bend diameter of 200 mm (8 in) / minimum bend radius of 100 mm (4 in).

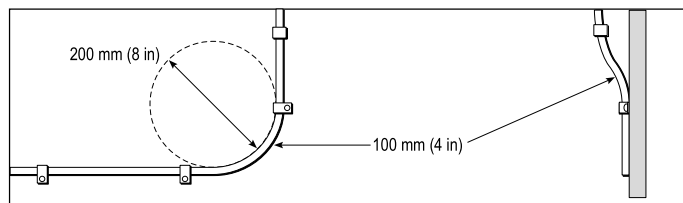

- Protect all cables from physical damage and exposure to heat. Use trunking or conduit where possible. Do NOT run cables through bilges or doorways, or close to moving or hot objects.
- Secure cables in place using tie-wraps or lacing twine. Coil any extra cable and tie it out of the way.
- Where a cable passes through an exposed bulkhead or deckhead, use a suitable watertight feed-through.
- Do NOT run cables near to engines or fluorescent lights.

Always route data cables as far away as possible from:

- other equipment and cables,
- high current carrying AC and DC power lines,
- antennae.

Strain relief

Ensure adequate strain relief is provided. Protect connectors from strain and ensure they will not pull out under extreme sea conditions.

Cable shielding

Ensure that all data cables are properly shielded that the cable shielding is intact (e.g. hasn't been scraped off by being squeezed through a tight area).

Suppression ferrites

Raymarine cables may be pre-fitted or supplied with suppression ferrites. These are important for correct EMC performance. If ferrites are supplied

separately to the cables (i.e. not pre-fitted), you must fit the supplied ferrites, using the supplied instructions.

- If a ferrite has to be removed for any purpose (e.g. installation or maintenance), it must be replaced in the original position before the product is used.
- Use only ferrites of the correct type, supplied by Raymarine or its authorized dealers.
- Where an installation requires multiple ferrites to be added to a cable, additional cable clips should be used to prevent stress on the connectors due to the extra weight of the cable.

4.2 Connections overview

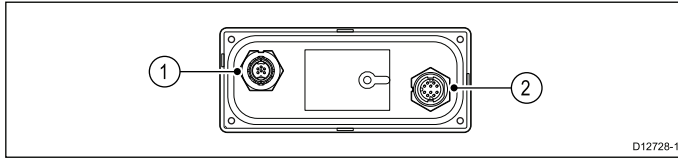

1. Alternate power connector
2. Network / PoE connector

The alternate power connector is required when connecting to a network which does not support Power over Ethernet PoE. The alternate power connector must be connected directly to a power supply.

Note: Do not connect the alternate power connector to a SeaTalk^{ng} network.

Note: Only use one power source. There is no need to connect the alternate power connector when the keypad is being supplied PoE.

4.3 Alternate power connection

When the keypad is not supplied Power over Ethernet (PoE) then the alternate power connection should be connected directly to a 12 V dc or 24 V dc power supply.

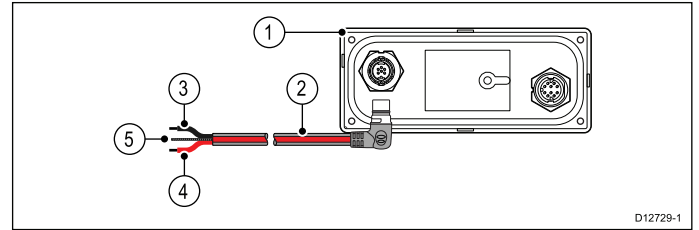

1. Keypad
2. Right angled power cable
3. Black negative wire
4. Ground / shield wire
5. Red positive wire



Warning: Product grounding

Before applying power to this product, ensure it has been correctly grounded, in accordance with the instructions provided.

Grounding — Dedicated drain wire

The power cable supplied with this product includes a dedicated shield (drain) wire for connection to a vessel's RF ground point.

It is important that an effective RF ground is connected to the system. A single ground point should be used for all equipment. The unit can be grounded by connecting the shield (drain) wire of the power cable to the vessel's RF ground point. On vessels without an RF ground system the shield (drain) wire should be connected directly to the negative battery terminal.

The dc power system should be either:

- Negative grounded, with the negative battery terminal connected to the vessel's ground.
- Floating, with neither battery terminal connected to the vessel's ground



Warning: Positive ground systems

Do not connect this unit to a system which has positive grounding.

4.4 Keypad connections

The keypad can be connected directly to a multifunction display's (MFDs) network connector or via a network switch. Multiple keypads can be connected to a system. Each keypad can be used to control multiple MFDs. If the network is not providing Power over Ethernet (PoE) then the keypad must be powered using the Alternate power connector.

Note: When connecting the keypad to a gS Series MFD, ensure that the supplied RayNet cable is connected with the suppression ferrite fitted on the end of the cable closest to the MFD.

Direct MFD connection with PoE

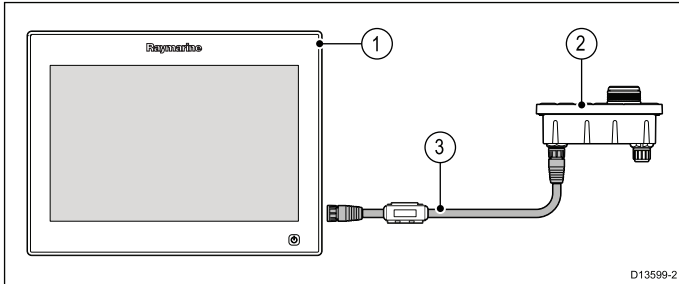

1. gS Series (MFD providing PoE)
2. RMK keypad
3. RayNet network cable (with suppression ferrite fitted)

Direct MFD connection without PoE

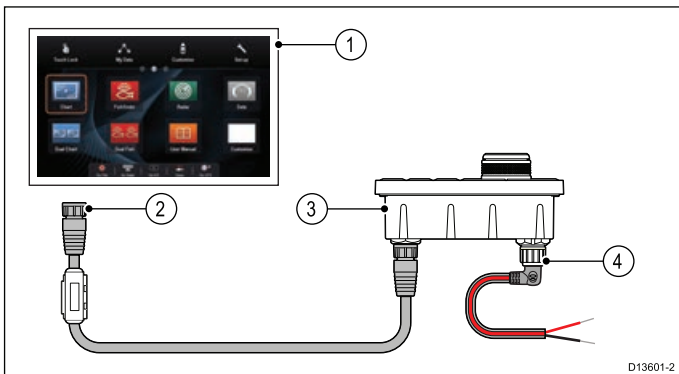

1. MFD
2. RayNet network cable
3. RMK keypad
4. Right angled power cable (Connected to the alternate power connector.)

Direct MFD connection with PoE injector

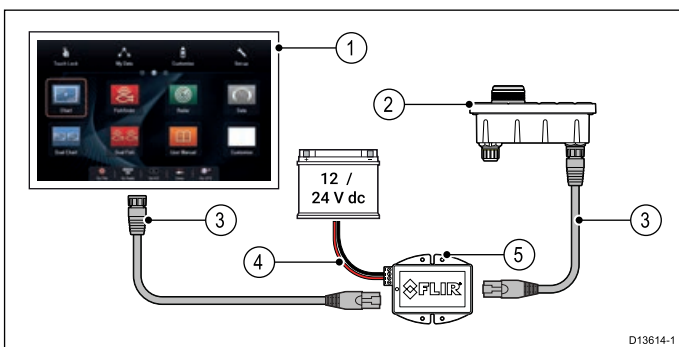

1. MFD
2. RMK keypad

3. RayNet to RJ45 network cable (A62360, A80151 or A80159)
4. PoE injector power supply (12 / 24 V dc)
5. PoE injector (R32141)

Network connection via MFD with PoE

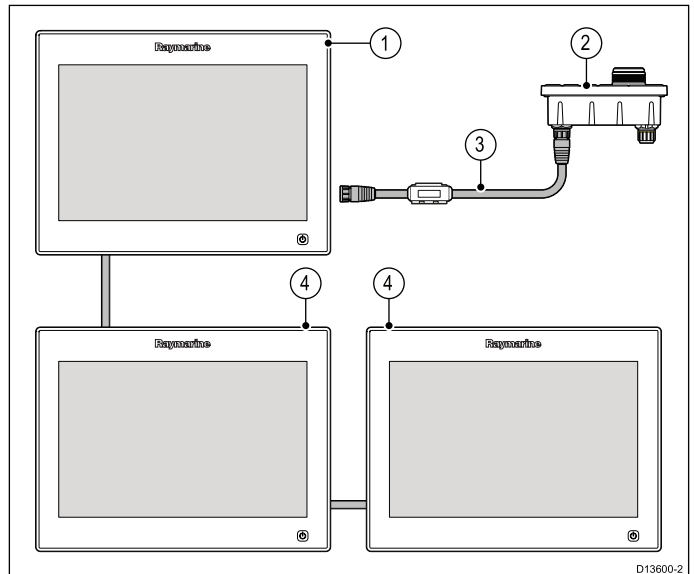

1. gS Series (MFD providing PoE)
2. RMK keypad
3. RayNet network cable (with suppression ferrite fitted)
4. Networked MFDs

Note: The keypad can be used to control networked MFDs even when the MFD it is connected to is switched off, as long as the MFD still has power supplied to it.

Network connection via network switch

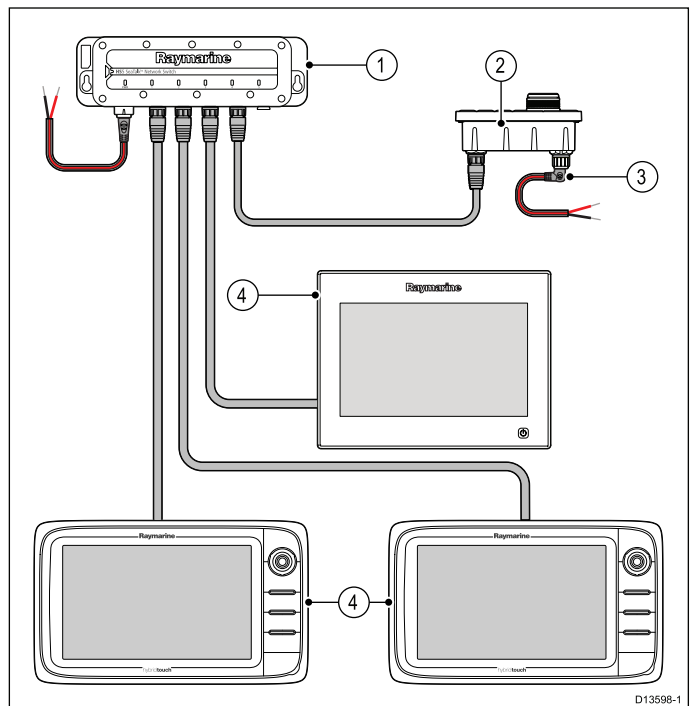

In the illustration above a PoE injector could be used instead of the Alternate power connection.

1. Network switch
2. RMK keypad

3. Right angled power cable (Connected to the alternate power connector.)
4. Networked MFDs

Note: Once connected the keypad must be paired with each MFD you want to control with the keypad.

5.1 Removing the keypad mat

To gain access to the mounting hole locations, the keypad mat must be removed.

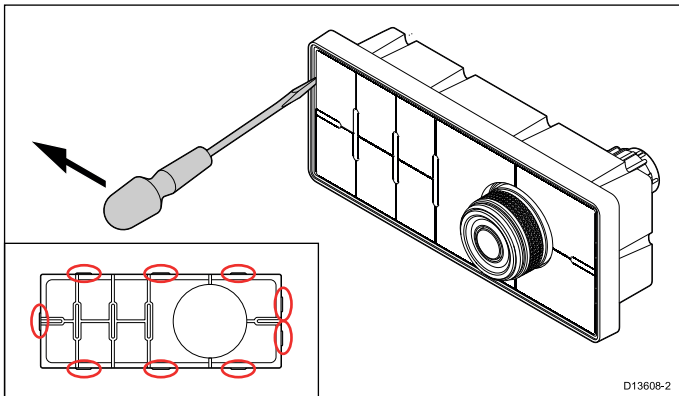

Tip To help prevent scratching the product, cover the tip of your screwdriver blade with a small piece of insulation tape.

1. Using a thin, flat bladed screwdriver insert the tip of the screwdriver into the gap between the edge of the keypad mat and the keypad housing, at a location between locking tabs.
2. Gently lever the keypad mat away from the keypad to release the keypad mat.

Take care not to bend the keypad mat during removal.

Flush mounting provides a sleek installation where the product and dash are flush, with only the buttons and Rotary controller protruding from the dash. Flush mounting requires the mounting surface to be rebated.

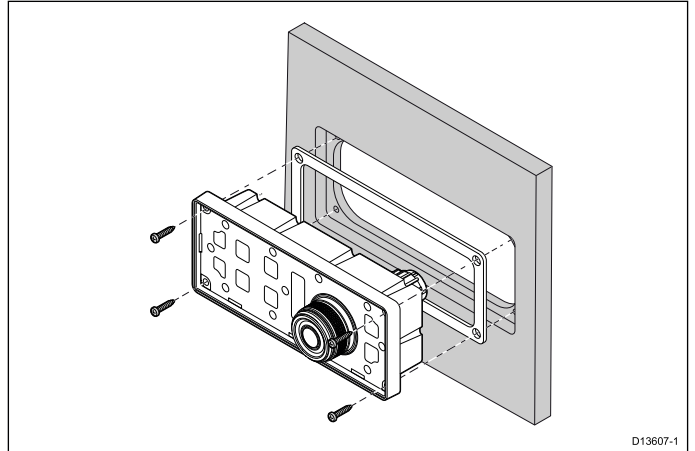

1. Check the selected location for the unit. A clear, flat area with suitable clearance behind the panel is required.
2. Before modifying the mounting surface, refer to the dimensions supplied in this document to ensure there is enough space for the unit and all cables.
3. Fix the supplied mounting template to the selected location, using masking or self adhesive tape.
4. Drill 4 holes as indicated on the mounting template to accept the fixings.
5. Using a suitable hole saw (the size and position is indicated on the template), make a hole in each corner of the cut-out area.
6. Using a suitable saw, cut along the inside edge of the cut-out line.
7. Using a Router, follow the Flush mount rebate line, to cut out a rebate to the specified rebate depth, as indicated on the template.
8. Ensure that the unit fits into the removed area and then remove rough edges.
9. Place the supplied gasket onto the rear of the keypad, ensuring the mounting holes are aligned.
10. Connect the relevant cables to the unit.
11. Place the keypad into the rebate and secure using the fixings provided.

Note: The appropriate tightening torque and drill bit size to use depends on the thickness of the mounting surface and the type of material it is made from.

Note: The supplied gasket provides a seal between the unit and a suitably flat and stiff mounting surface or binnacle. The gasket should be used in all installations. It may also be necessary to use a marine-grade sealant if the mounting surface or binnacle is not entirely flat and stiff or has a rough surface finish.

5.3 Surface mounting the keypad

Surface mounting provides a uniform installation where the products protrude, usually by the thickness of the bezel, from the mounting surface.

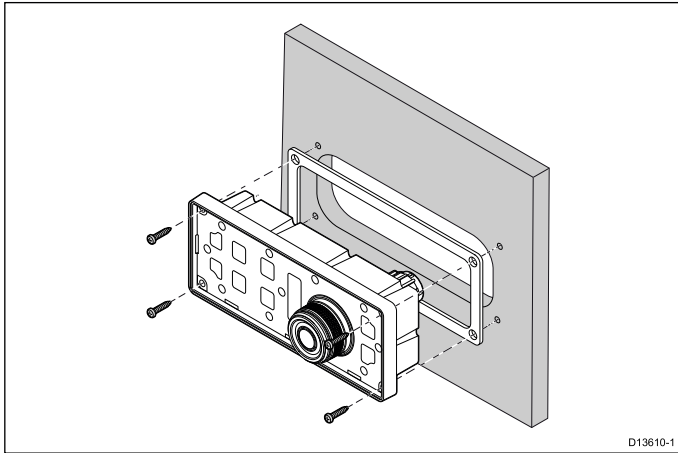

1. Check the selected location for the unit. A clear, flat area with suitable clearance behind the panel is required.
2. Before modifying the mounting surface, refer to the dimensions supplied in this document to ensure there is enough space for the unit and all cables.
3. Fix the supplied mounting template to the selected location, using masking or self adhesive tape.
4. Drill 4 holes as indicated on the mounting template to accept the fixings.
5. Using a suitable hole saw, make a hole in each corner of the cut-out area.
6. Using a suitable saw, cut along the inside edge of the cut-out line.
7. Ensure that the unit fits into the removed area and then remove rough edges.
8. Place the supplied gasket onto the rear of the keypad, ensuring the mounting holes are aligned.
9. Connect the relevant cables to the unit.
10. Secure using the fixings provided.

Note: The appropriate tightening torque and drill bit size to use depends on the thickness of the mounting surface and the type of material it is made from.

Note: The supplied gasket provides a seal between the unit and a suitably flat and stiff mounting surface or binnacle. The gasket should be used in all installations. It may also be necessary to use a marine-grade sealant if the mounting surface or binnacle is not entirely flat and stiff or has a rough surface finish.

5.4 Fitting the keypad mat

Your keypad can be installed in portrait or landscape orientation. keypad mats are available for each orientation.

- You should fit the keypad mat that matches your chosen mounting orientation.
 - You should only fit the keypad mat after the unit has been secured to the mounting surface.
1. Ensure the keypad mat is orientated correctly.
 2. Slide the keypad mat's shorter edge, with the 2 locking tabs, into the end of the keypad that has 2 notches to accept the tabs.

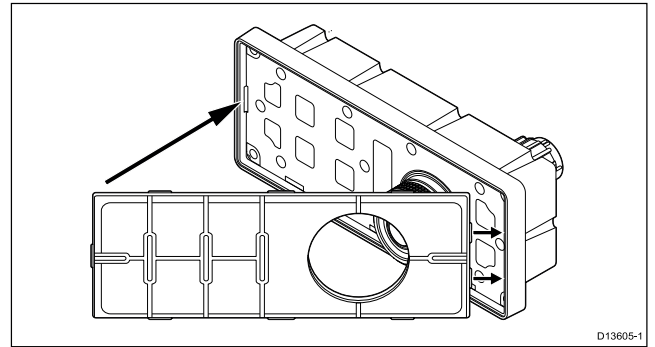

3. Close the opposite end of the keypad mat into the keypad, ensuring that the tab slides into the notch provided, push all of the tabs on the longer sides into their notches (you should hear a click as each tab engages).

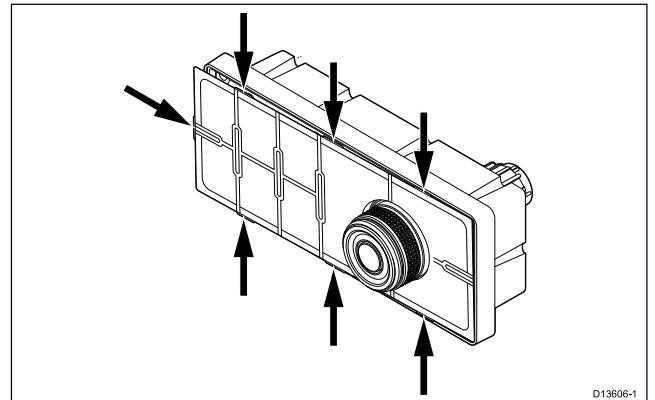

Chapter 6: Operation

6.1 Keypad controls

Connecting the keypad allows you to control your multifunction display remotely.

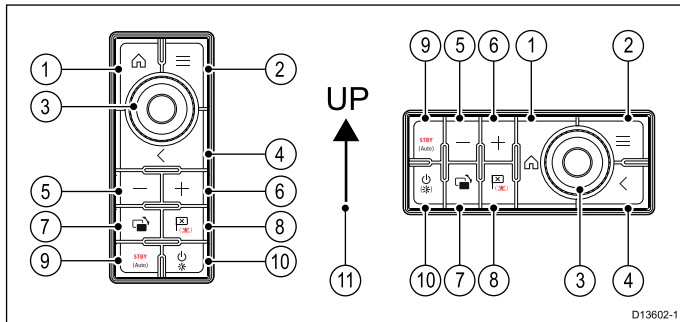

Note: * Only applicable to eS and gS Series displays. a Series, c Series and e Series displays cannot be powered on using the keypad.

Note: In a multiple display configuration, where displays are in different states, displays that are turned off can only be turned on using the **Power** button on the display.

11. Direction of Joystick Up.

1. **Home** — press to return to the Homescreen.
2. **Menu** — accesses menus. Press again to close menus.
3. **UniController** — provides a rotary control and a joystick that includes an OK push button for using menus and applications.
4. **Back** — press to return to a previous menu or dialog level.
5. - (Minus/Negative symbol) — press to range out.
6. + (Plus/Positive symbol) — press to range in.
7. **Active** — press to switch the active pane, or to switch the active multifunction display (in multiple display systems).
8. **Waypoint / MOB** — press and release to access the waypoint options. Press again to place a waypoint. Press and hold to place a Man Overboard (MOB) marker at your current position.
9. **Standby (Auto)** — press to disengage integrated autopilot, press and hold to activate Auto mode on integrated autopilot.
10. **Power** — see table below:

Configura-tion	Display State	Momentary press	Press and hold
1 Multifunction display	Off / Standby	* Power on	—
	On	Open Shortcuts page	Power off / put into Standby
Multiple multifunction displays	All displays Off or in Standby	* Power on all displays	—
	All displays On	Open Shortcuts page on active display	Power down all displays
	1 Display On and 1 display Off or in Standby	Open Shortcuts page on active display	Power down active display

6.2 Pairing the keypad

Each keypad can be paired with multiple MFDs and multiple keypads can be connected to the same system.

With the keypad connected to the MFD:

1. Select **External Keypad** from the External Devices menu: **homescreen > Set-up > System Settings > External Devices > External Keypad**.
2. Select **Pair Keypad**.
3. Press any button on the external keypad.
4. From the pop-up message select the orientation of the keypad.

Either landscape or portrait orientations are available.

The keypad is now paired.

Switching the active pane or display using the keypad

The **Active** button is used to switch the active pane on a multi application page and / or to switch the active display.

With multiple displays connected and / or a multiple application page displayed:

Cycle sequence

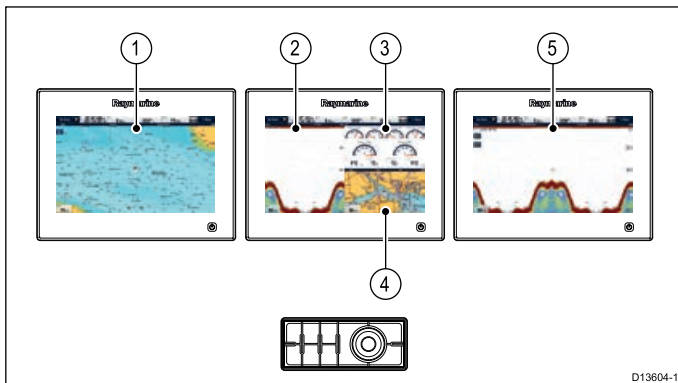

1. Press the **Active** button to enter switch mode.
2. Use the **Rotary** control to cycle through the available panes and / or displays.

The keypad will cycle through displays in the order in which they were paired. On multi application pages the + and - buttons can be used to switch the active application between full and splitscreen.

3. Press the **Back** button or the **Active** button to exit switch mode.

Unpairing the keypad

The keypad can be unpaired from an individual display.

1. Select **External Keypad** from the External Devices menu: **homescreen > Set-up > System Settings > External Devices > External Keypad**.

2. Select **Clear Pairings**.
3. Select **Yes** to unpair the keypad with the display.

Unpairing from all displays

The keypad can be unpaired from all displays following the steps below.

1. Press and hold the **Range In** and **Range Out** buttons simultaneously for approximately 6 seconds.

The keypad will sound a triple beep to signify it is now unpaired.

Determining the active display

You can determine which display is currently active.

1. Press the **Active** button.
The Active pop-up is displayed on the screen or pane that is active.
2. Press the **Active** button again to close the Active pop-up.
The active display remains the same.

Chapter 7: System checks and troubleshooting

7.1 Keypad status

The keypad is backlit with LEDs. The LEDs are used to identify the status of the keypad.

Status	UniController LED ring	Keypad backlight
Keypad powered off or not paired	Off	Off
Keypad is powered on and paired	On	On
MFD is in PowerSave mode	Flashing	Off

The LED and keypad backlight brightness will change to match the paired MFD brightness.

7.2 PoE troubleshooting

If you are experiencing connection issues with the remote keypad when powering the device via PoE, consider using the keypad's dedicated power connector to supply the power to the device.

Possible causes for connection issues are:

- Low or inconsistent voltage at the power supply to the MFD.
- Inadequate power or data cabling.
- If multiple devices are powered via PoE from the MFD, the power allocation for the PoE devices may be too high, either because there are too many device connected, or the total power consumption exceeds the supported allocation. Refer to the Power over Ethernet (PoE) topic in the MFD's Installation instructions document for more information on the PoE power allocation.

7.3 Power up troubleshooting

Problems at power up and their possible causes and solutions are described here.

Product does not turn on or keeps turning off

Possible causes	Possible solutions
Blown fuse / tripped breaker	<ol style="list-style-type: none"> 1. Check condition of relevant fuses and breakers and connections, replace if necessary (Refer to the <i>Technical Specification</i> section of your product's installation instructions for fuse ratings.) 2. If fuse keeps blowing check for cable damage, broken connector pins or incorrect wiring.
Poor / damaged / insecure power supply cable / connections	<ol style="list-style-type: none"> 1. Check that the power cable connector is fully inserted into the unit and locked in position. 2. Check the power supply cable and connectors for signs of damage or corrosion, replace if necessary. 3. With the unit turned on, try flexing the power cable near to the display connector to see if this causes the unit to re-boot/loose power, replace if necessary. 4. Check the vessel's battery voltage, the condition of the battery terminals and power supply cables, ensuring connections are secure, clean and free from corrosion, replace if necessary. 5. With the product under load, using a multi-meter, check for high voltage drop across all connectors/fuses etc, replace if necessary.
Incorrect power connection	The power supply may be wired incorrectly, ensure the installation instructions have been followed.
Power source insufficient	With the product under load, using a multi-meter, check the power supply voltage as close to the unit as possible to establish actual voltage when the current is flowing. (Refer to the <i>Technical Specification</i> section of your product's installation instructions for power supply requirements.)

Product will not boot up (re-boot loop)

Possible causes	Possible solutions
Power supply and connection	See possible solutions from 'Products does not turn on or keeps turning off' above.
Software corruption	<ol style="list-style-type: none"> 1. In the unlikely event that the products software has become corrupted please try re-flashing the latest software from the Raymarine website. 2. On display products, as a last resort, you can try to perform a 'Power on Reset', however this will delete all settings/presets and user data (such as waypoints and tracks) and revert the unit back to factory defaults.

Chapter 8: Maintenance

8.1 Service and maintenance

This product contains no user serviceable components. Please refer all maintenance and repair to authorized Raymarine dealers. Unauthorized repair may affect your warranty.

8.2 Routine equipment checks

Raymarine strongly recommends that you complete a number of routine checks to ensure the correct and reliable operation of your equipment.

Complete the following checks on a regular basis:

- Examine all cables for signs of damage or wear and tear.
- Check that all cables are securely connected.

8.3 Product cleaning

Best cleaning practices.

When cleaning products:

- Lightly rinse or flush with clean, cool fresh water.
- If your product has a display screen, do NOT wipe the screen with a dry cloth, as this could scratch the screen coating.
- Do NOT use: abrasive, acidic, ammonia, solvent of chemical based cleaning products.
- Do NOT use a jet wash.

Chapter 9: Technical specification

9.1 Technical specification

Power specification

PoE class	Class 1
Nominal supply voltage	<ul style="list-style-type: none">PoE: 48 V dcAlternate power: 12 V / 24 V dc
Operating voltage range	<ul style="list-style-type: none">PoE: 44 V to 57 V dcAlternate power: 9 V to 32 V dc
Power consumption	4 W Max with full keypad illumination

Environmental specification

Operating temperature	-25 °C to +55 °C (-13 °F to 131 °F)
Storage temperature	-30 °C to +70 °C (-22 °F to 158 °F)
Relative humidity	Maximum 93%
Waterproof rating	IPx6 & IPx7

Wired connections

Network / PoE	1 x RayNet 10/100 Mb/s connector
Alternate power	1 x Power connector (SeaTalkng® style connector)

9.2 Compliance

The product has been tested to the relevant sections of the standards listed below.

Ethernet/PoE	<ul style="list-style-type: none">IEEE 802.3IEEE 802.3af (PoE)
EMC	<ul style="list-style-type: none">EN60945

Chapter 10: Technical support

10.1 Raymarine product support and servicing

Raymarine provides a comprehensive product support service, as well as warranty, service, and repairs. You can access these services through the Raymarine website, telephone, and e-mail.

Product information

If you need to request service or support, please have the following information to hand:

- Product name.
- Product identity.
- Serial number.
- Software application version.
- System diagrams.

You can obtain this product information using the menus within your product.

Servicing and warranty

Raymarine offers dedicated service departments for warranty, service, and repairs.

Viewing product information

With your MFD Homescreen displayed:

1. Select **Set-up**.
2. Select **Maintenance**.
3. Select **Diagnostics**.
4. Select **Select Device**.
5. Select the relevant product from the list.

The Diagnostics page is displayed.

10.2 Learning resources

Raymarine has produced a range of learning resources to help you get the most out of your products.

Training courses

Raymarine regularly runs a range of in-depth training courses to help you make the most of your products.

FAQs and Knowledge Base

Raymarine has produced an extensive set of FAQs and a Knowledge Base to help you find more information and troubleshoot any issues.

Technical support forum

You can use the Technical support forum to ask a technical question about a Raymarine product or to find out how other customers are using their Raymarine equipment.

Chapter 11: Spares and accessories

11.1 Keypad spares and accessories

Spares

Item	Part number
Portrait keypad mat spare	R70509
Landscape keypad mat spare	R70508

Accessories

Item	Part number
Right angled 2 m (6.6 ft) power cable	A06070
Straight 2 m (6.6 ft) power cable	A06049

RayNet to RayNet cables and connectors

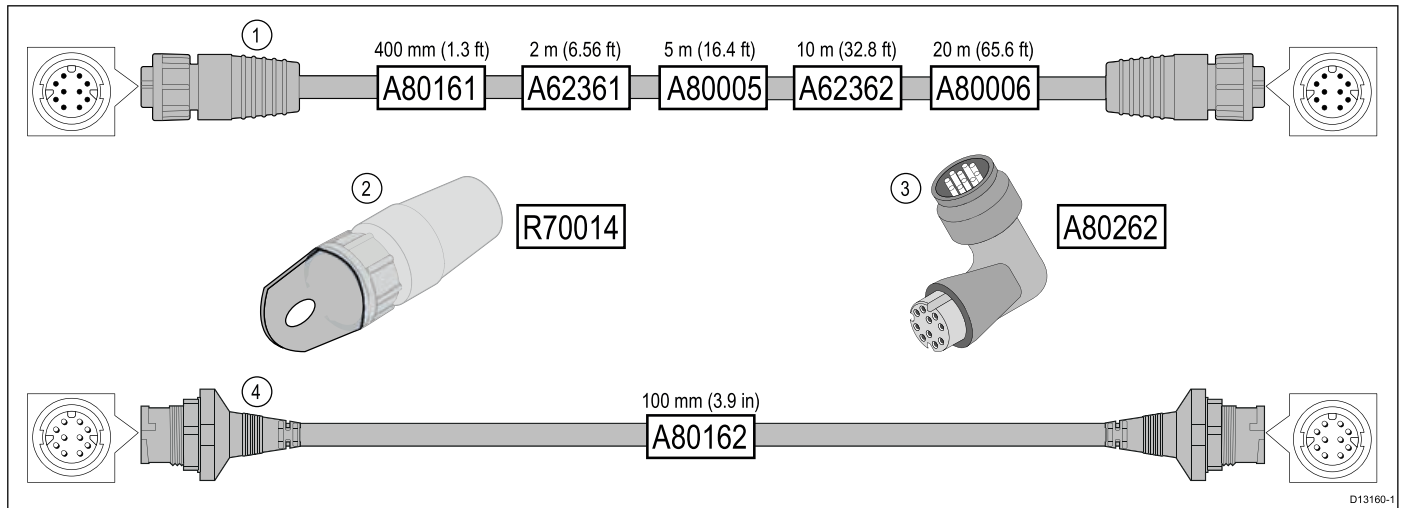

D13160-1

	Description	Typical use	Quantity
1	Standard RayNet connection cable with a RayNet (female) socket on both ends.	Suitable for connecting all RayNet equipment directly to LightHouse multifunction displays featuring a RayNet connector. Can also be used to connect RayNet equipment via a RayNet network switch (e.g. HS5).	1
2	RayNet cable puller (5 pack).	These “handles” securely attach to the twist-lock on RayNet cables, enabling you to pull the cables through conduits and other obstacles.	5
3	RayNet to RayNet right-angle coupler / adapter.	Suitable for connecting RayNet cables at 90° (right angle) to devices, for installations where space is limited. For example, use this adapter to connect a RayNet cable to a multifunction display when there is not enough space behind the display for the usual cable bend radius required by a standard RayNet cable. This adapter features a RayNet (female) socket at one end, and a RayNet (male) plug at the other end.	1
4	Adapter cable with a RayNet (male) plug on both ends.	Suitable for joining (female) RayNet cables together for longer cable runs.	1

RayNet to RJ45 adapter cables

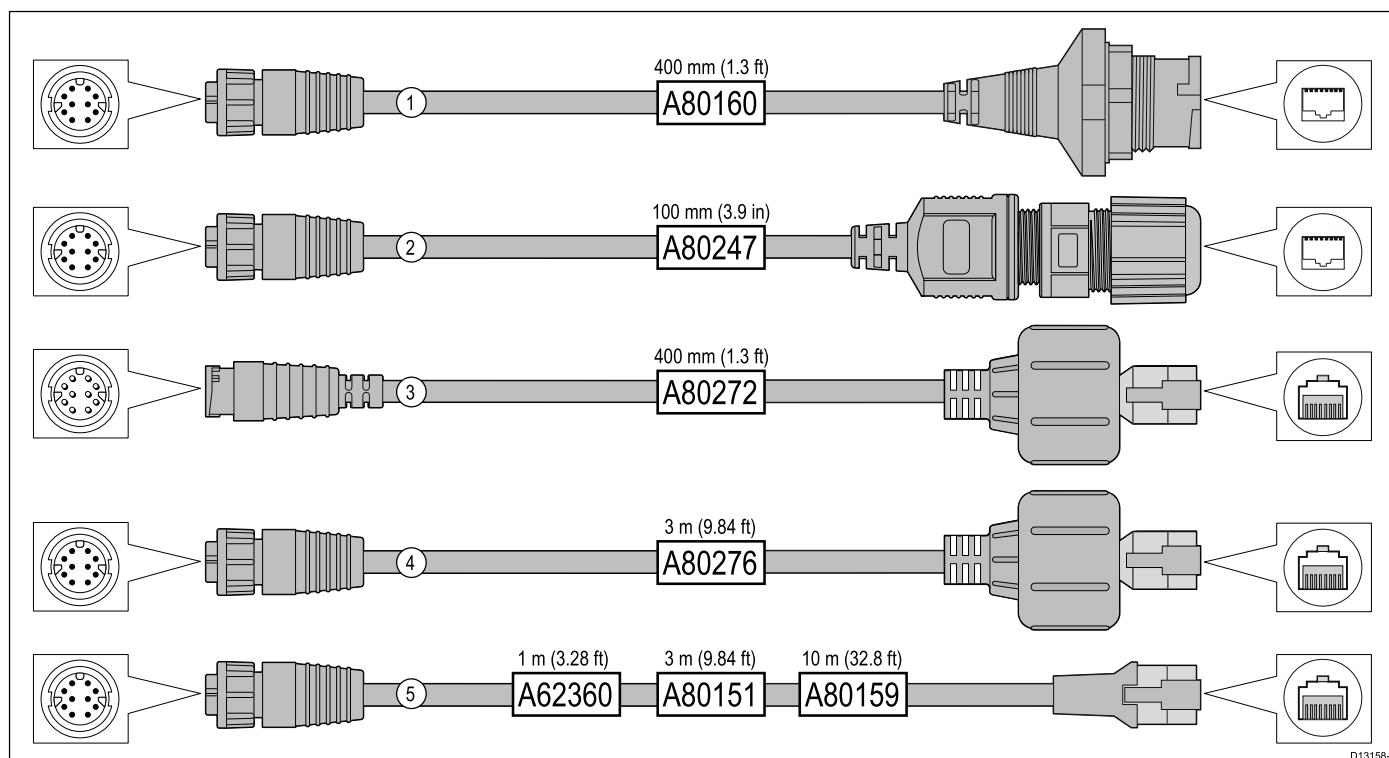

D13158-1

	Description	Typical use	Quantity
1	<p>Adapter cable with a RayNet (female) socket on one end, and a waterproof (female) socket on the other end accepting the following cables with an RJ45 SeaTalk^{hs} waterproof locking (male) plug:</p> <ul style="list-style-type: none"> • A62245 (1.5 m). • A62246 (15 m). 	<p>A typical use for this adapter cable is to connect a DSM300 sonar module to a LightHouse MFD, using all-waterproof cable connections. This adapter cable will also accept the following RJ45 SeaTalk^{hs} cables, although the RJ45 plug that connects at the equipment end (e.g. DSM300) will NOT be waterproof:</p> <ul style="list-style-type: none"> • E55049 (1.5 m). • E55050 (5 m). • E55051 (10 m). • A62135 (15 m). • E55052 (20 m). 	1
2	<p>Adapter cable with a RayNet (female) socket on one end, and a waterproof (female) RJ45 socket on the other end, along with a locking gland for a watertight fit.</p>	<p>Directly connect a Raymarine radar scanner with an RJ45 SeaTalk^{hs} (male) cable to a RayNet network switch (e.g. HS5) or LightHouse MFD.</p>	1
3	<p>Adapter cable with a RayNet (male) plug on one end, and an RJ45 SeaTalk^{hs} waterproof (male) plug on the other end.</p>	<p>Connect a legacy G-Series GPM-400, C-Series Widescreen or E-Series Widescreen MFD to a Raymarine radar scanner supplied with a RayNet power / data cable.</p>	1
4	<p>Adapter cable with a RayNet (female) socket on one end, and an RJ45 SeaTalk^{hs} waterproof (male) plug on the other end.</p>	<p>Connect a legacy G-Series GPM-400, C-Series Widescreen or E-Series Widescreen MFD to a RayNet network switch (e.g. the HS5).</p>	1
5	<p>Adapter cable with a RayNet (female) socket on one end, and an RJ45 SeaTalk^{hs} (female) socket on the other end.</p>	<p>Connect a LightHouse MFD to a legacy SR6 switch / weather receiver or a legacy 8-port SeaTalk^{hs} network switch. Another common use for the cable is in conjunction with a crossover coupler (E55060 or R32142) to connect Raymarine products with an RJ45 connection (e.g. radar scanner, thermal camera or DSM300) to a LightHouse MFD or RayNet network switch (e.g. the HS5).</p>	1