

Raymarine®



AR200

Installation instructions

Trademark and patents notice

Raymarine, Tacktick, Clear Pulse, Truzoom, SeaTalk, SeaTalk^{hs}, SeaTalk^{ng}, and Micronet, are registered or claimed trademarks of Raymarine Belgium.

FLIR, LightHouse, DownVision, SideVision, RealVision, Dragonfly, Quantum, Axiom, Instalert, Infrared Everywhere, The World's Sixth Sense and ClearCruise are registered or claimed trademarks of FLIR Systems, Inc.

All other trademarks, trade names, or company names referenced herein are used for identification only and are the property of their respective owners.

This product is protected by patents, design patents, patents pending, or design patents pending.

Fair Use Statement

You may print no more than three copies of this manual for your own use. You may not make any further copies or distribute or use the manual in any other way including without limitation exploiting the manual commercially or giving or selling copies to third parties.

Chapter 1: Important information



Warning: Product installation and operation

- This product must be installed and operated in accordance with the instructions provided. Failure to do so could result in personal injury, damage to your vessel and/or poor product performance.
- Raymarine recommends certified installation by a Raymarine approved installer. A certified installation qualifies for enhanced product warranty benefits. Contact your Raymarine dealer for further details, and refer to the separate warranty document packed with your product.



Warning: Potential ignition source

This product is NOT approved for use in hazardous/flammable atmospheres. Do NOT install in a hazardous/flammable atmosphere (such as in an engine room or near fuel tanks).



Warning: Product grounding

Before applying power to this product, ensure it has been correctly grounded, in accordance with the instructions provided.



Warning: Positive ground systems

Do not connect this unit to a system which has positive grounding.



Warning: Switch off power supply

Ensure the vessel's power supply is switched OFF before starting to install this product. Do NOT connect or disconnect equipment with the power switched on, unless instructed in this document.



Warning: Power supply voltage

Connecting this product to a voltage supply greater than the specified maximum rating may cause permanent damage to the unit. Refer to the *Technical specification* section for voltage rating.

Caution: Power supply protection

When installing this product ensure the power source is adequately protected by means of a suitably-rated fuse or automatic circuit breaker.

Caution: Product cleaning

When cleaning products:

- Lightly rinse or flush with clean, cool fresh water.
- If your product has a display screen, do NOT wipe the screen with a dry cloth, as this could scratch the screen coating.
- Do NOT use: abrasive, acidic, ammonia, solvent or chemical based cleaning products.
- Do NOT use a jet wash.

Caution: Service and maintenance

This product contains no user serviceable components. Please refer all maintenance and repair to authorized Raymarine dealers. Unauthorized repair may affect your warranty.

Water ingress

Water ingress disclaimer

Although the waterproof rating capacity of this product meets the stated water ingress protection standard (refer to the product's *Technical Specification*), water intrusion and subsequent equipment failure may occur if the product is subjected to commercial high-pressure washing. Raymarine will not warrant products subjected to high-pressure washing.

Disclaimer

Raymarine does not warrant that this product is error-free or that it is compatible with products manufactured by any person or entity other than Raymarine.

Raymarine is not responsible for damages or injuries caused by your use or inability to use the product, by the interaction of the product with products manufactured by others, or by errors in information utilized by the product supplied by third parties.

Suppression ferrites

- Raymarine cables may be pre-fitted or supplied with suppression ferrites. These are important for correct EMC performance. If ferrites are supplied separately to the cables (i.e. not pre-fitted), you must fit the supplied ferrites, using the supplied instructions.
- If a ferrite has to be removed for any purpose (e.g. installation or maintenance), it must be replaced in the original position before the product is used.
- Use only ferrites of the correct type, supplied by Raymarine or its authorized dealers.
- Where an installation requires multiple ferrites to be added to a cable, additional cable clips should be used to prevent stress on the connectors due to the extra weight of the cable.

Connections to other equipment

Requirement for ferrites on non-Raymarine cables

If your Raymarine equipment is to be connected to other equipment using a cable not supplied by Raymarine, a suppression ferrite **MUST** always be attached to the cable near the Raymarine unit.

Declaration of conformity

FLIR Belgium BVBA declares that the following products are in compliance with the EMC Directive 2014/30/EU:

- AR200 Augmented Reality Sensor, part number E70537

Product disposal

Dispose of this product in accordance with the WEEE Directive.

The Waste Electrical and Electronic Equipment (WEEE) Directive requires the recycling of waste electrical and electronic equipment which contains materials, components and substances that may be hazardous and present a risk to human health and the environment when WEEE is not handled correctly.



Equipment marked with the crossed-out wheeled bin symbol indicates that the equipment should not be disposed of in unsorted household waste.

Local authorities in many regions have established collection schemes under which residents can dispose of waste electrical and electronic equipment at a recycling center or other collection point.

IMO and SOLAS

The equipment described within this document is intended for use on leisure marine boats and workboats NOT covered by International Maritime Organization (IMO) and Safety of Life at Sea (SOLAS) Carriage Regulations.

Technical accuracy

To the best of our knowledge, the information in this document was correct at the time it was produced. However, Raymarine cannot accept liability for any inaccuracies or omissions it may contain. In addition, our policy of continuous product improvement may change specifications without notice. As a result, Raymarine cannot accept liability for any differences between the product and this document. Please check the Raymarine website to ensure you have the most up-to-date version(s) of the documentation for your product.

Chapter 2: Document and product information

Chapter contents

- 2.1 Product documentation
- 2.2 Applicable products
- 2.3 AR200 product overview
- 2.4 Required additional components
- 2.5 Parts supplied
- 2.6 Software updates

2.1 Product documentation

The following documentation is applicable to your product:

Description	Part number
AR200 Installation instructions (This document)	87372
Deck and bracket mounting template	87170

Document illustrations

Your product and if applicable, its user interface may differ slightly from that shown in the illustrations in this document, depending on product variant and date of manufacture.

All images are provided for illustration purposes only.

Operation instructions

For detailed operation instructions for your product, refer to the documentation that accompanies your display.

2.2 Applicable products

This document is applicable to the following products:

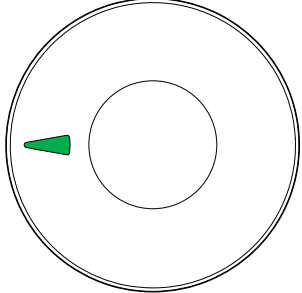
	Part number	Name	Description
	E70537	AR200	SeaTalkng® Augmented Reality Sensor

2.3 AR200 product overview

The AR200 is an Augmented Reality Sensor consisting of a Global Navigation Satellite Systems (GNSS) Receiver and an Attitude and Heading Reference System (AHRS) sensor. The AR200 provides position, heading, pitch and roll data to compatible Axiom MFDs running LightHouse™ 3 Version 3.7 or above that are on the same SeaTalkng® network. When combined with a compatible IP camera enables use of the ClearCruise™ Augmented Reality features available on your MFD.

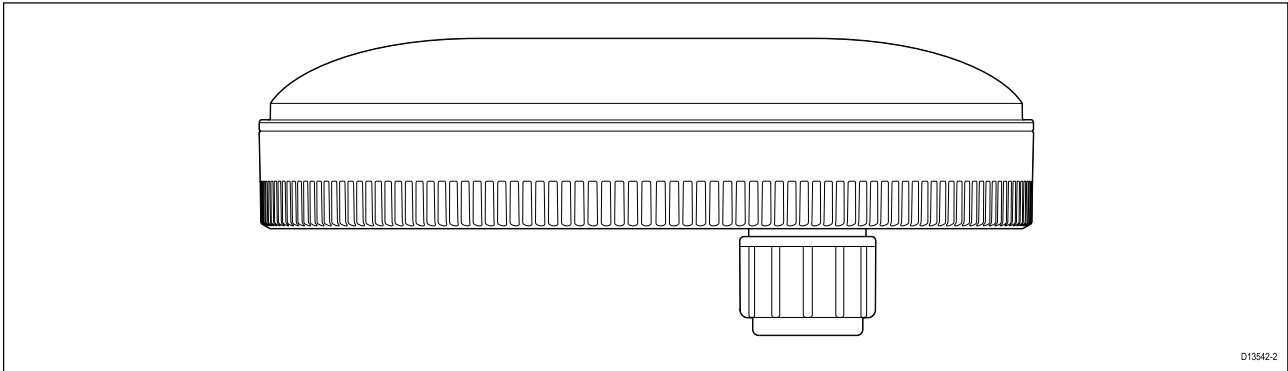

The **AR200** has the following features:

- Enables the ClearCruise™ Augmented Reality feature on your MFD.
- 9-axis AHRS (Attitude and Heading Reference System) sensor.
- Compatible with GPS, and GLONASS GNSS systems.
- BeiDou and Galileo ready (supported by future software update).
- Automatic calibration.
- Pole, Rail, Surface or Bracket mountable (mounting kits available).
- Can be used as a source of GNSS (GPS) position and Heading data for other devices in your network. Please refer to the Multiple data sources (MDS) information in your MFD operation instructions for details.
- 10 Hz refresh rate.
- NMEA 2000 compliant.
- Low power consumption.
- 12 V DC operation (protected up to 32 V DC) via the SeaTalkng® network.
- Waterproof to IPx6 and IPx7.

2.4 Required additional components

The AR200 forms part of the ClearCruise™ Augmented Reality System and requires the following additional components to enable the feature on your system.

- Compatible IP camera. Refer to **Compatible IP cameras** for a list of compatible products.
- Axiom LightHouse™ 3 Multifunction display. Refer to **Compatible MFDs** for a list of compatible MFDs.

Compatible IP cameras

The following cameras are compatible with the AR200:

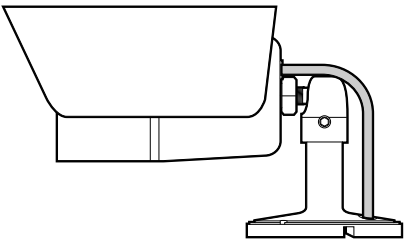
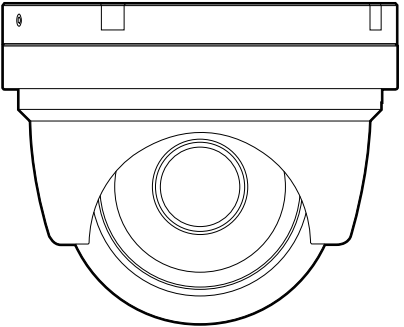
	Product name	Product number
	CAM210IP	E70346
	CAM220IP	E70347

Compatible MFDs

The following MFDs are compatible with the AR200:

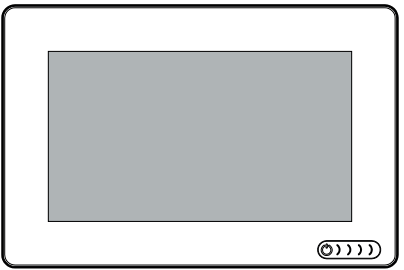
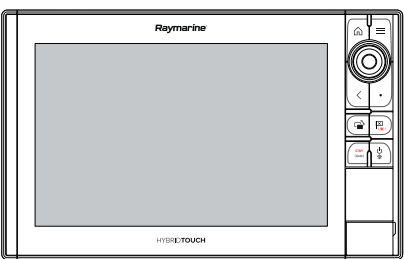
	Description	Part number(s)
	Axiom™ 7 Chartplotter variants	E70363, E70363-DISP
	Axiom™ 7 DV variants	E70364, E70364-01, E70364-02, E70364-DISP
	Axiom™ 7 RV 3D variants	E70365, E70365-03, E70365-DISP
	Axiom™ 9 Chartplotter variants	E70366, E70366-DISP
	Axiom™ 9 RV 3D variants	E70367, E70367-02, E70367-03, E70367-DISP
	Axiom™ 12 Chartplotter variants	E70368, E70368-DISP
	Axiom™ 12 RV 3D variants	E70369, E70369-03, E70369-DISP
	Axiom™ Pro 9 RVX	E70371
	Axiom™ Pro 9 S	E70481
	Axiom™ Pro 12 RVX	E70372
	Axiom™ Pro 12 S	E70482
	Axiom™ Pro 16 RVX	E70373
	Axiom™ Pro 16 S	E70483

	Description	Part number(s)
	Axiom™ XL 16	E70399
	Axiom™ XL 19	E70400
	Axiom™ XL 22	E70515
	Axiom™ XL 24	E70401

2.5 Parts supplied

The following parts are supplied with your product.

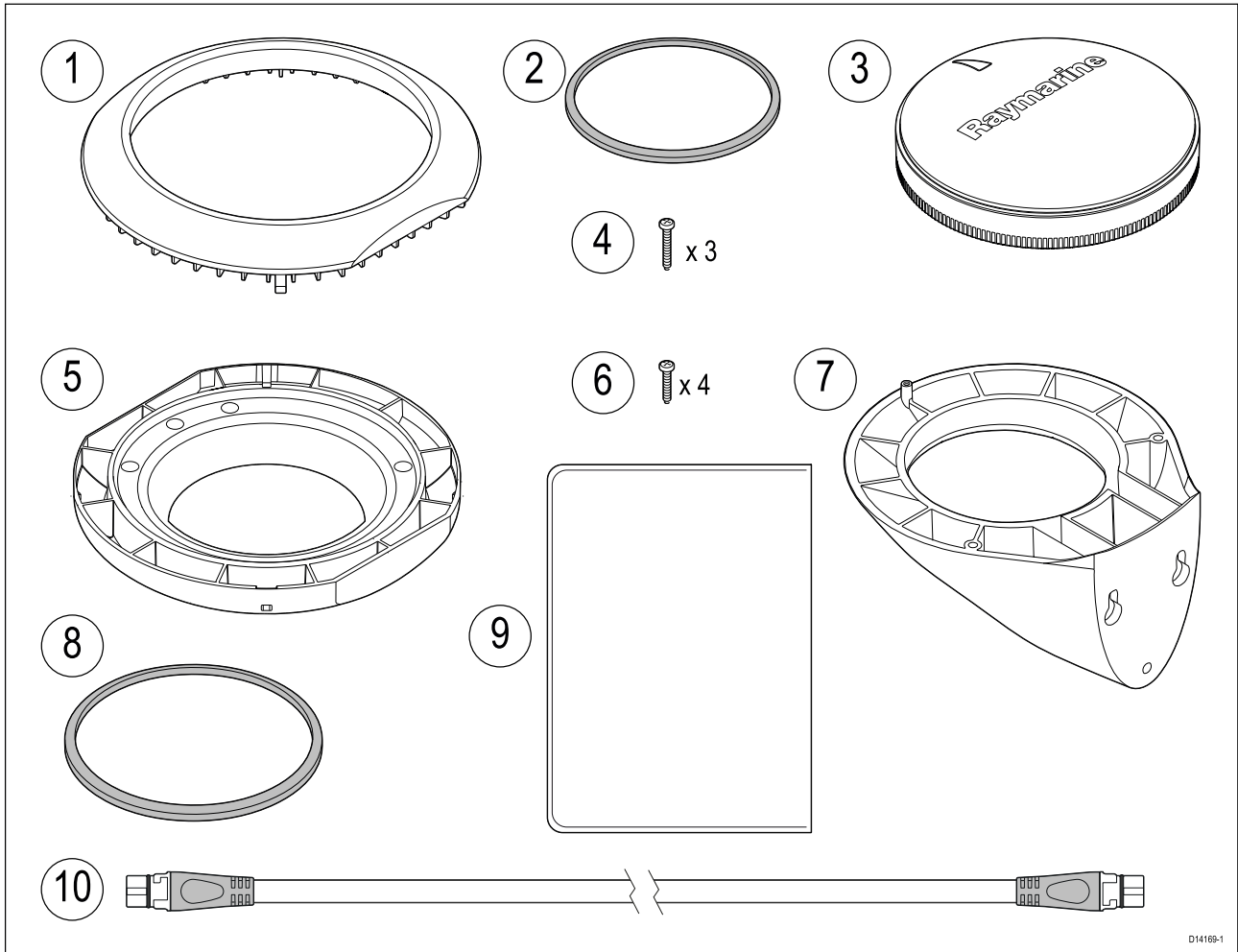

1. Mounting trim (Top).
2. Small sealing ring.
3. AR200.
4. 3 x large bulkhead bracket fixings (Pan head pozi DIN7981 ST 3.9x22 C Z A4 Stainless steel).
5. Mounting tray (Bottom).
6. 4 x small surface mount fixings (Pan head pozi DIN7981-ST 2.9x13 C Z A4 Stainless steel).
7. Bulkhead (Wall) bracket.
8. Large sealing ring.
9. Documentation.
10. 6 m (19.69 ft) SeaTalkng® (White) cable.

Unpack your product carefully to prevent damage or loss of parts, check the box contents against the list above. Retain the packaging and documentation for future reference.

2.6 Software updates

The software running on the product can be updated.

- Raymarine periodically releases software updates to improve product performance and add new features.
- The software on many products can be updated using a connected and compatible multifunction display (MFD).

Important:

- To prevent potential software-related issues with your product, always follow the relevant update instructions carefully and in the sequence provided.
- If in doubt as to the correct procedure for updating your product software, refer to your dealer or Raymarine technical support.

Caution: Installing software updates

The software update process is carried out at your own risk. Before initiating the update process ensure you have backed up any important files.

Ensure that the unit has a reliable power supply and that the update process is not interrupted.

Damage caused by incomplete updates are not covered by Raymarine warranty.

By downloading the software update package, you agree to these terms.

Chapter 3: Installation

Chapter contents

- 3.1 Tools required for installation
- 3.2 Selecting a location
- 3.3 Mounting

3.1 Tools required for installation

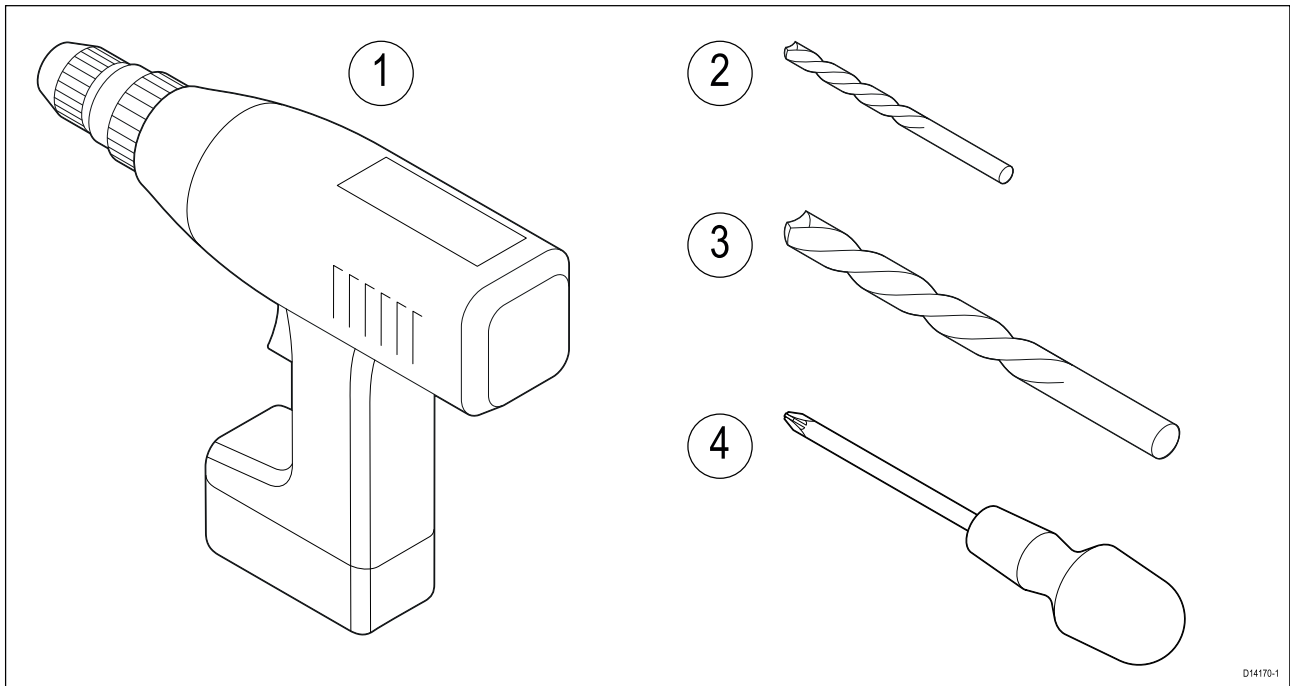

1	Power drill
2	Suitable size drill bit (for Bulkhead bracket mounting) Note: Drill bit size is dependent on the type of material the unit is to be mounted on.
3	12 mm ($15/32$ ") drill bit (if required, for cable hole)
4	Pozi-drive screwdriver

3.2 Selecting a location

Warnings and cautions

Important: Before proceeding, ensure that you have read and understood the warnings and cautions provided in the Chapter 1 **Important information** section of this document.



Warning: Switch off power supply

Ensure the vessel's power supply is switched OFF before starting to install this product. Do NOT connect or disconnect equipment with the power switched on, unless instructed in this document.



Warning: Potential ignition source

This product is NOT approved for use in hazardous/flammable atmospheres. Do NOT install in a hazardous/flammable atmosphere (such as in an engine room or near fuel tanks).

Location requirements

The installation location must take into account the following requirements:

- The unit should be installed above decks.
- Choose a location that provides the most unobstructed view of the sky in all directions:

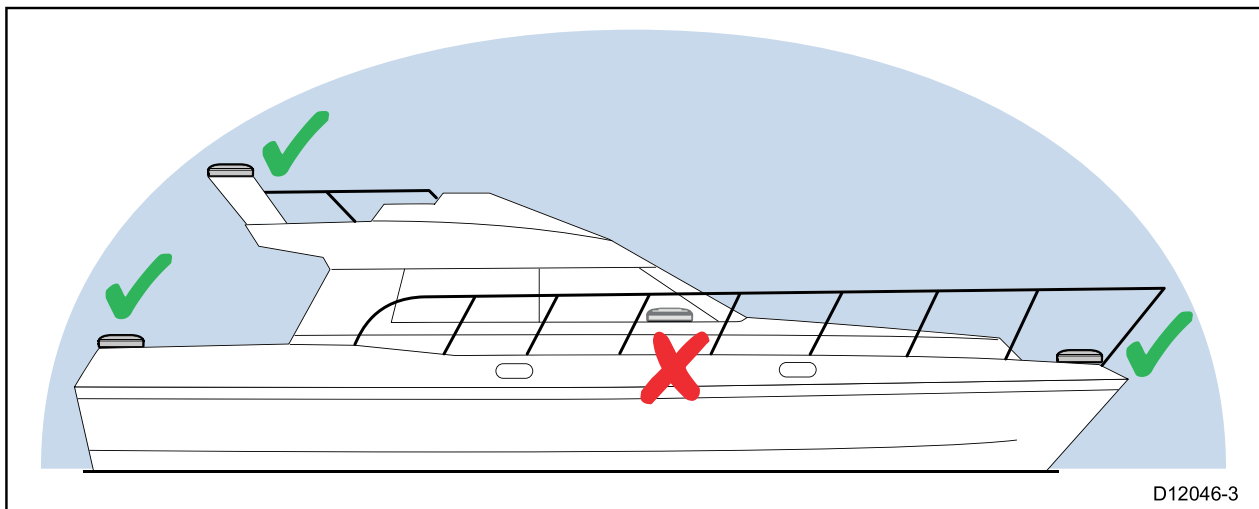

- The unit must be mounted on a horizontal and level surface. The installed unit must be level within **5°** of pitch and **5°** of roll (compared with the vessel's neutral position when at rest and normally laden).

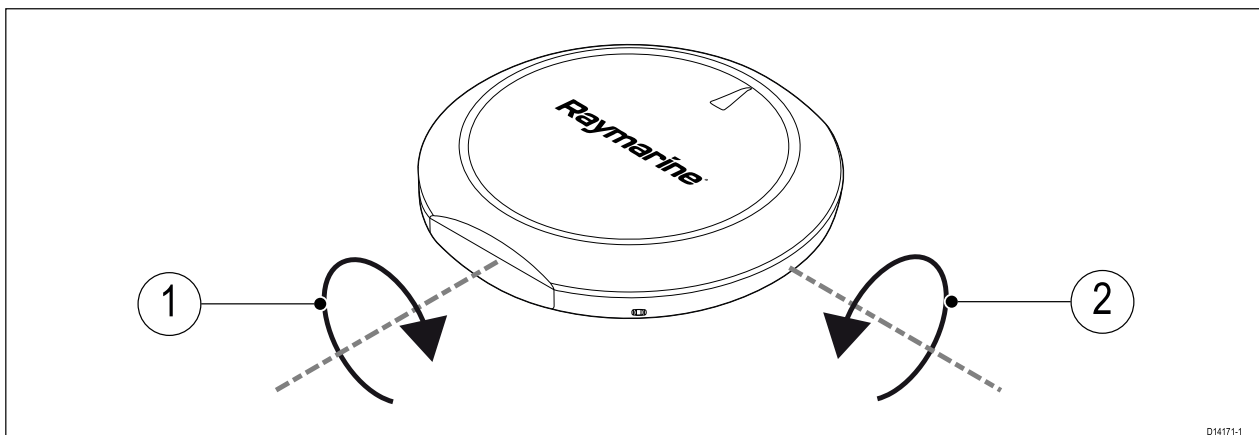

1. Roll
2. Pitch

- The unit can be mounted on a vertical surface such as a bulkhead or mast etc, using the supplied bulkhead bracket.
- Do NOT mount on top of a mast.
- The unit location must be at least 1 m (3 ft.) away from any source of magnetic interference, such as compasses and electrical cables.
- Choose a location where the unit will be safe from physical damage and excessive vibration.
- Choose a location where the unit will not be subjected to a load or force.
- Mount away from any source of heat or potential flammable hazards, such as fuel vapor.
- The unit should be mounted in a location where the diagnostics LED is viewable.
- The unit must be mounted with the LED 'arrow' on the top of the unit pointing forwards, in parallel alignment with the longitudinal axis (centerline) of the vessel.

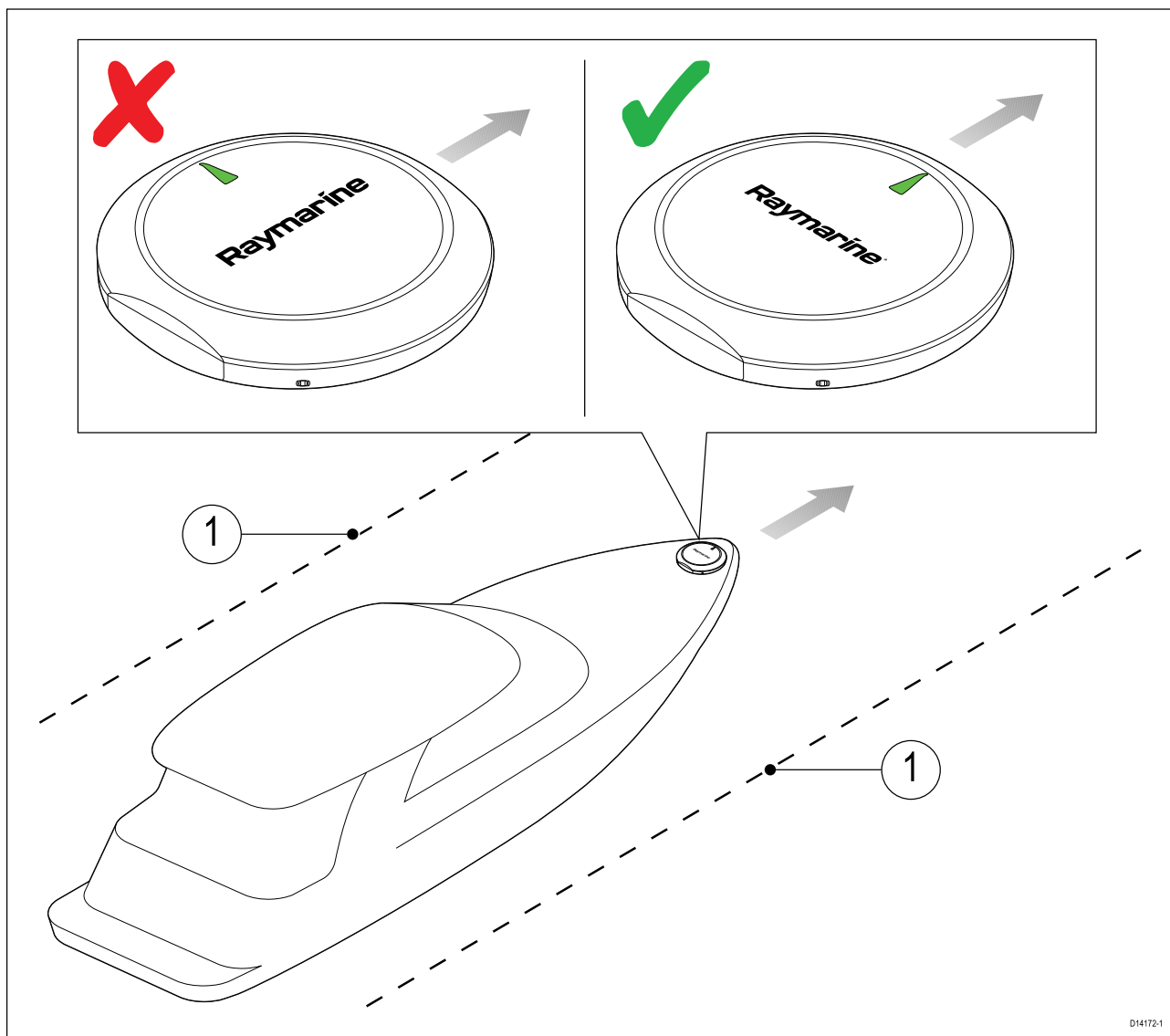

1. Vessel's longitudinal axis.

RF interference

Certain third-party external electrical equipment can cause Radio Frequency (RF) interference with GNSS (GPS), AIS or VHF devices, if the external equipment is not adequately insulated and emits excessive levels of electromagnetic interference (EMI).

Some common examples of such external equipment include LED lighting (e.g.: navigation lights, searchlights and floodlights, interior and exterior lights) and terrestrial TV tuners.

To minimize interference from such equipment:

- Keep it as far away from GNSS (GPS), AIS or VHF products and their antennas as possible.

- Ensure that any power cables for external equipment are not entangled with the power or data cables for these devices.
- Consider fitting one or more high frequency suppression ferrites to the EMI-emitting device. The ferrite(s) should be rated to be effective in the range 100 MHz to 2.5 GHz, and should be fitted to the power cable and any other cables exiting the EMI-emitting device, as close as possible to the position where the cable exits the device.

Compass safe distance

To prevent potential interference with the vessel's magnetic compasses, ensure an adequate distance is maintained from the product.

When choosing a suitable location for the product you should aim to maintain the maximum possible distance from any compasses. Typically this distance should be at least 1 m (3.3 ft) in all directions. However for some smaller vessels it may not be possible to locate the product this far away from a compass. In this situation, when choosing the installation location for your product, ensure that the compass is not affected by the product when it is in a powered state.

EMC installation guidelines

Raymarine equipment and accessories conform to the appropriate Electromagnetic Compatibility (EMC) regulations, to minimize electromagnetic interference between equipment and minimize the effect such interference could have on the performance of your system

Correct installation is required to ensure that EMC performance is not compromised.

Note: In areas of extreme EMC interference, some slight interference may be noticed on the product. Where this occurs the product and the source of the interference should be separated by a greater distance.

For **optimum** EMC performance we recommend that wherever possible:

- Raymarine equipment and cables connected to it are:
 - At least 1 m (3.3 ft) from any equipment transmitting or cables carrying radio signals e.g. VHF radios, cables and antennas. In the case of SSB radios, the distance should be increased to 2 m (6.6 ft).
 - More than 2 m (6.6 ft) from the path of a radar beam. A radar beam can normally be assumed to spread 20 degrees above and below the radiating element.
- The product is supplied from a separate battery from that used for engine start. This is important to prevent erratic behavior and data loss which can occur if the engine start does not have a separate battery.
- Raymarine specified cables are used.
- Cables are not cut or extended, unless doing so is detailed in the installation manual.

Note:

Where constraints on the installation prevent any of the above recommendations, always ensure the maximum possible separation between different items of electrical equipment, to provide the best conditions for EMC performance throughout the installation.

Product dimensions

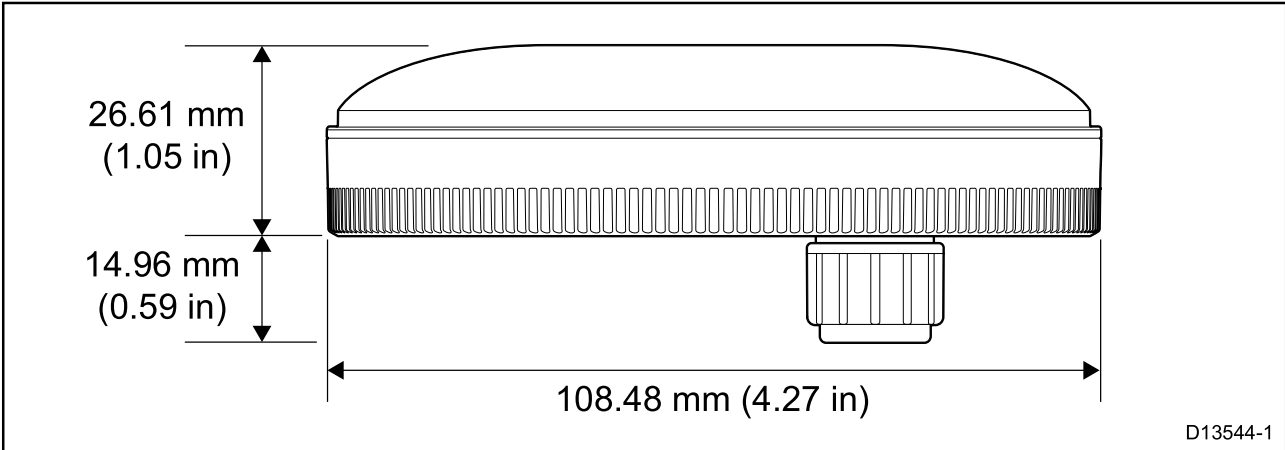

3.3 Mounting

Bulkhead mounting

The supplied mounting brackets can be used to mount your product horizontally on a bulkhead. Ensure that the chosen location meets the product's location requirements, see 3.2 **Selecting a location** for details.

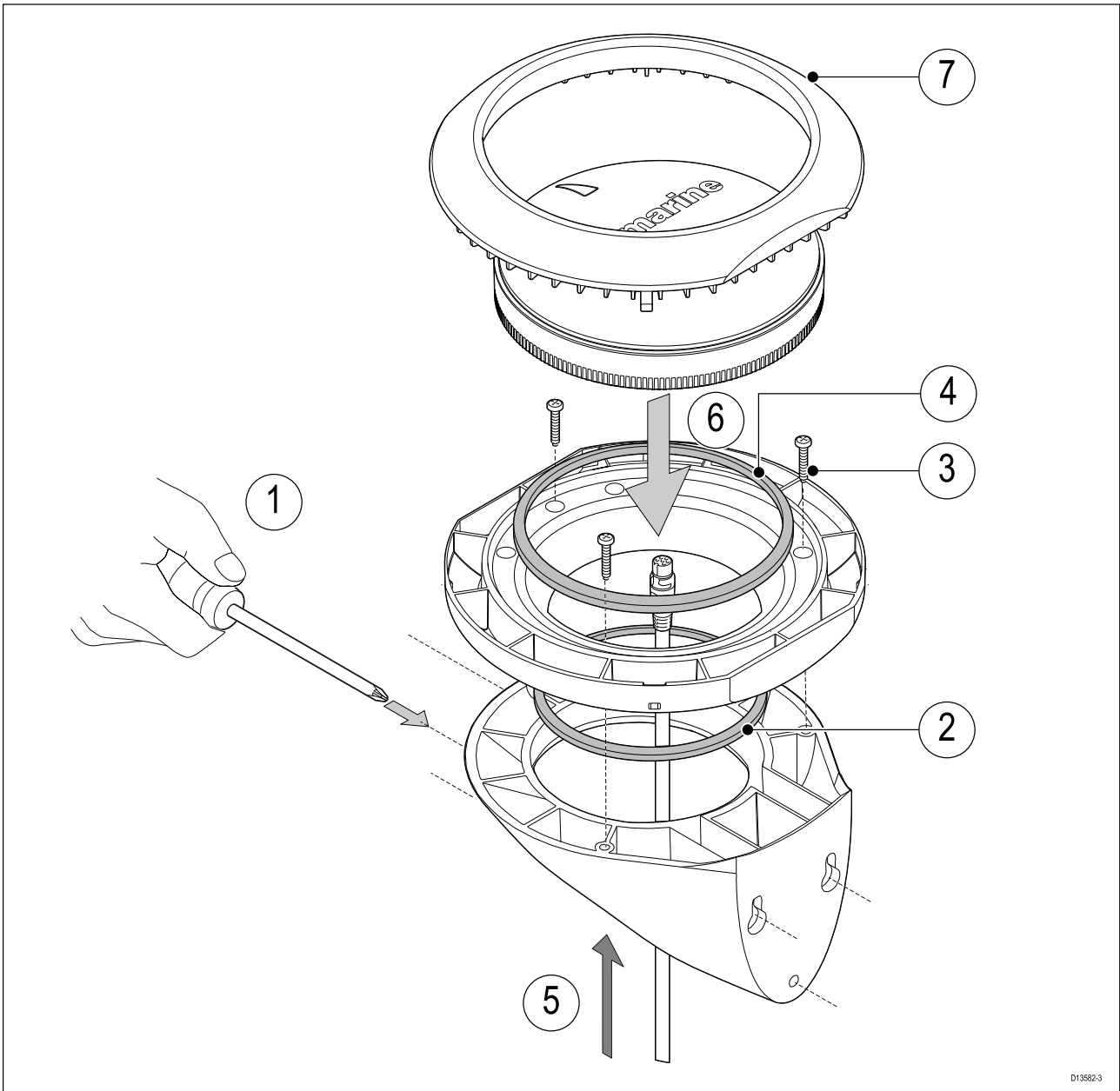

1. Use the supplied Bracket mounting template (87170) to drill 3 pilot holes in the vertical mounting surface. Secure the mounting bracket to the surface using the supplied screws.
2. Place the small sealing ring in the groove located on the bottom of the Mounting tray.
3. Secure the tray to the bracket using 3 of the supplied screws, in the positions indicated in the illustration above.
4. Place the large sealing ring into the groove on the upper side of the Mounting tray.
5. Pull the SeaTalkng[®] cable through the center of the bracket and tray. Plug in the cable connector on the underside of the unit and secure by rotating the locking collar clockwise 2 clicks.
6. Insert the unit into the mounting tray, ensuring the tabs in the Mounting tray are slotted into the grooves around the edge of the unit.

Important:

The unit must be mounted with the LED 'arrow' on the top of the unit pointing forwards, in parallel alignment with the longitudinal axis (centerline) of your vessel.

7. Orientate the Mounting trim so that the release hole will be accessible once mounted.

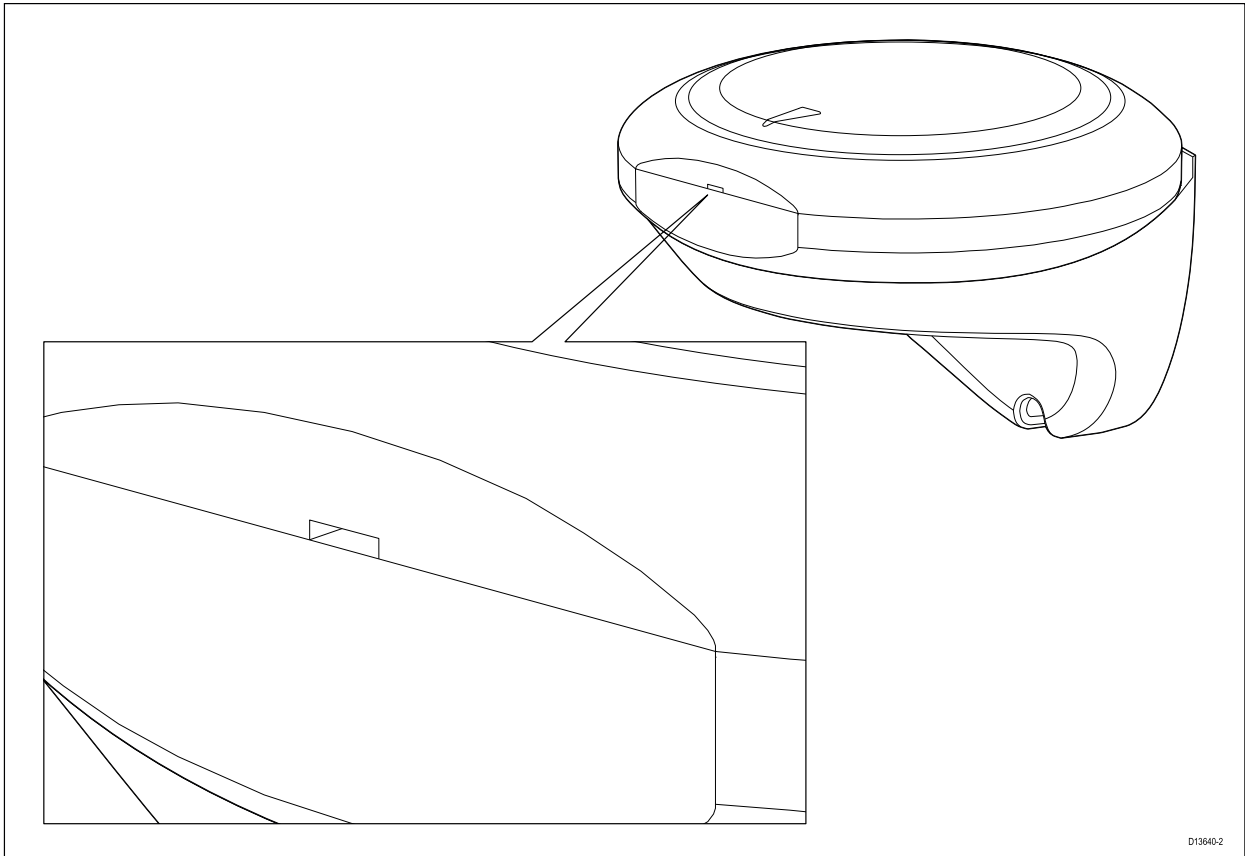

8. Place the Mounting trim over the unit slightly offset, and then twist the Mounting trim clockwise until it locks into position.

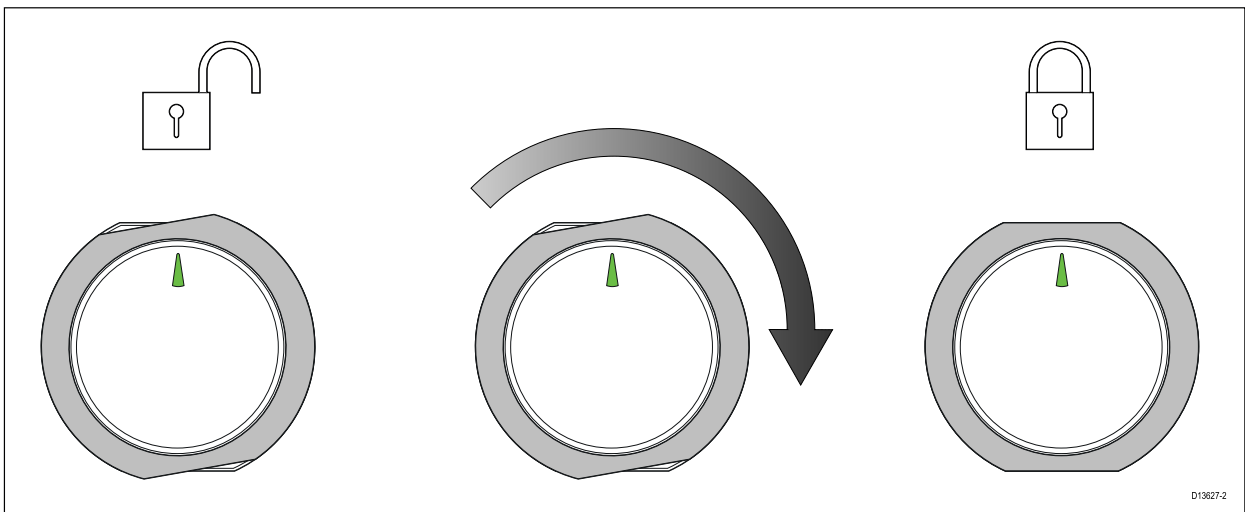

Surface mounting

The supplied mounting bracket can be used to mount your product horizontally or vertically on a flat surface.

The Bulkhead bracket is not required for this type of installation.

Ensure that the chosen location meets the product's location requirements, see 3.2 **Selecting a location** for details.

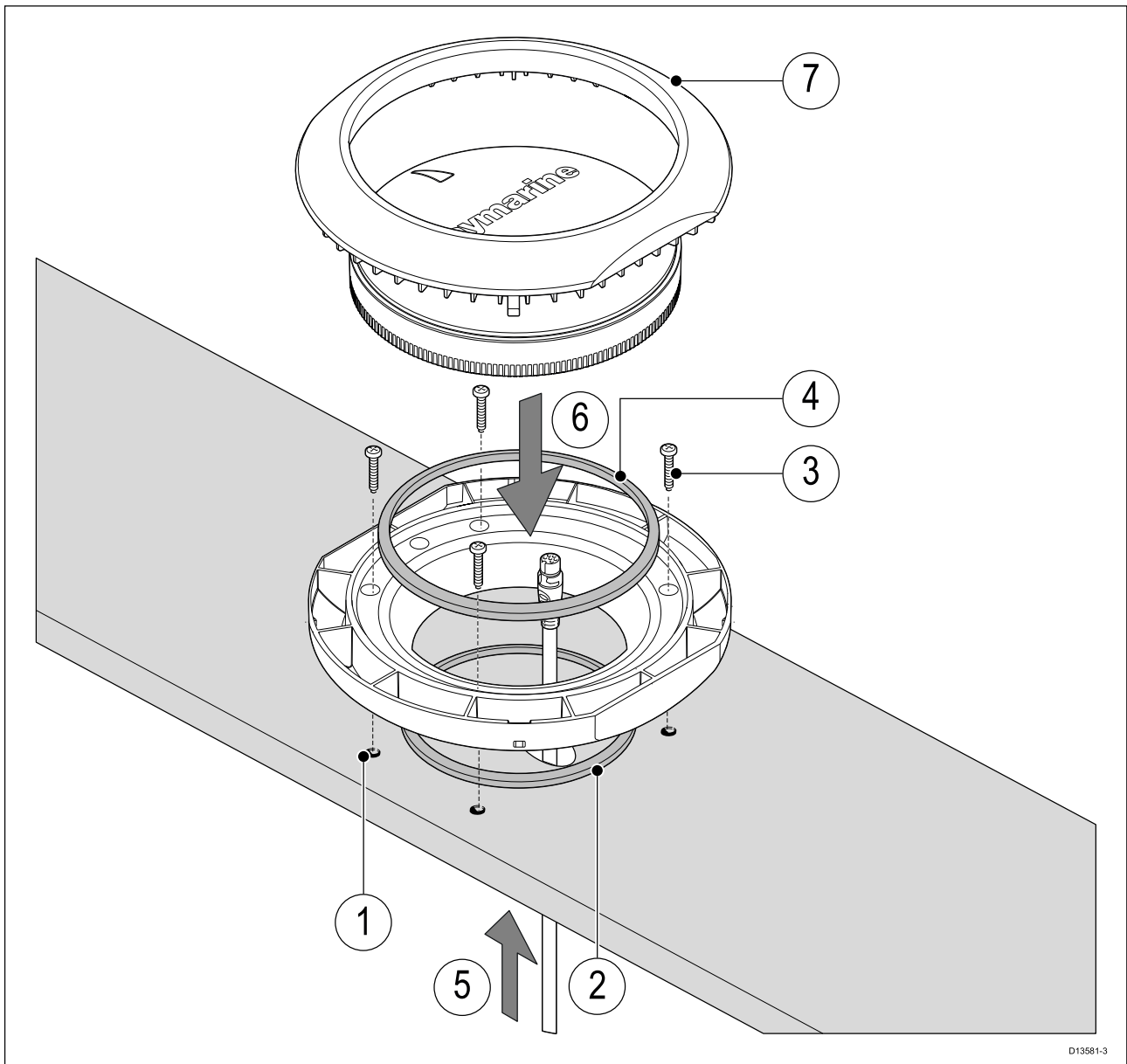

D13581-3

1. Using the supplied Mounting tray template (87170), drill 4 holes in the mounting surface, plus a 12 mm ($15/32$ ") hole for the SeaTalkng[®] cable.
2. Place the small sealing ring in the groove located on the bottom of the mounting tray.
3. Secure the tray to the mounting surface using the 4 x fixings, supplied.
4. Place the large sealing ring into the groove on the upper side of the Mounting tray.
5. Pull the SeaTalkng[®] cable through the mounting surface hole and the Mounting tray. Plug in the cable connector on the underside of the unit and secure by rotating the locking collar clockwise 2 clicks.
6. Insert the unit into the mounting tray, ensuring the tabs in the Mounting tray are slotted into the grooves around the edge of the unit.

Important:

The unit must be mounted with the LED 'arrow' on the top of the unit pointing towards the vessel's bow and be in parallel alignment with the longitudinal axis (centerline) of your vessel.

7. Place the Mounting trim over the unit slightly offset, and then twist the Mounting trim clockwise until it locks into position.

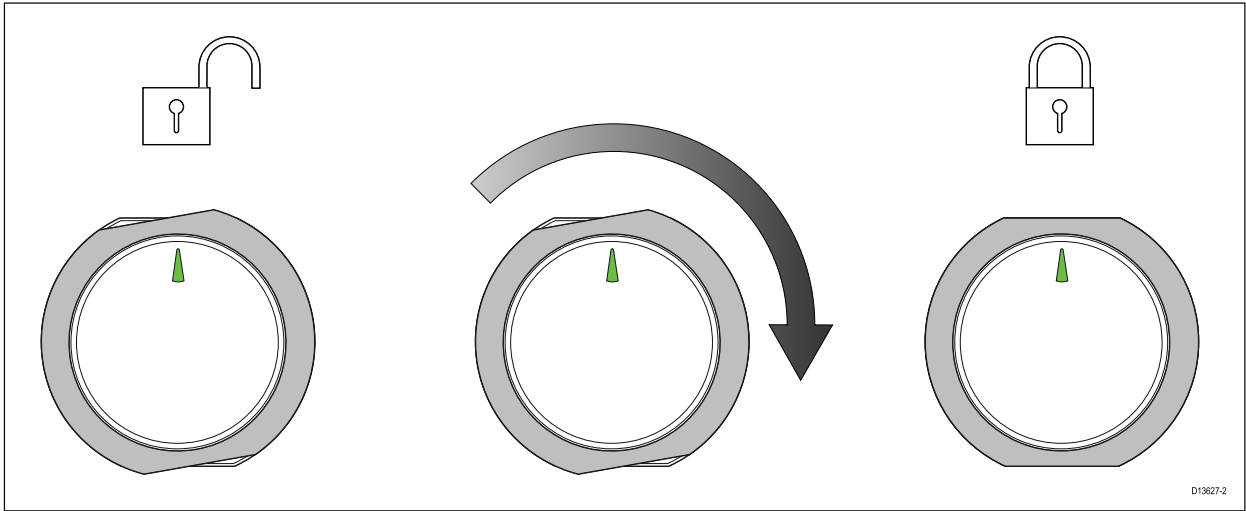

Releasing the unit from the bracket

Follow the steps below to release the unit from the Mounting bracket.

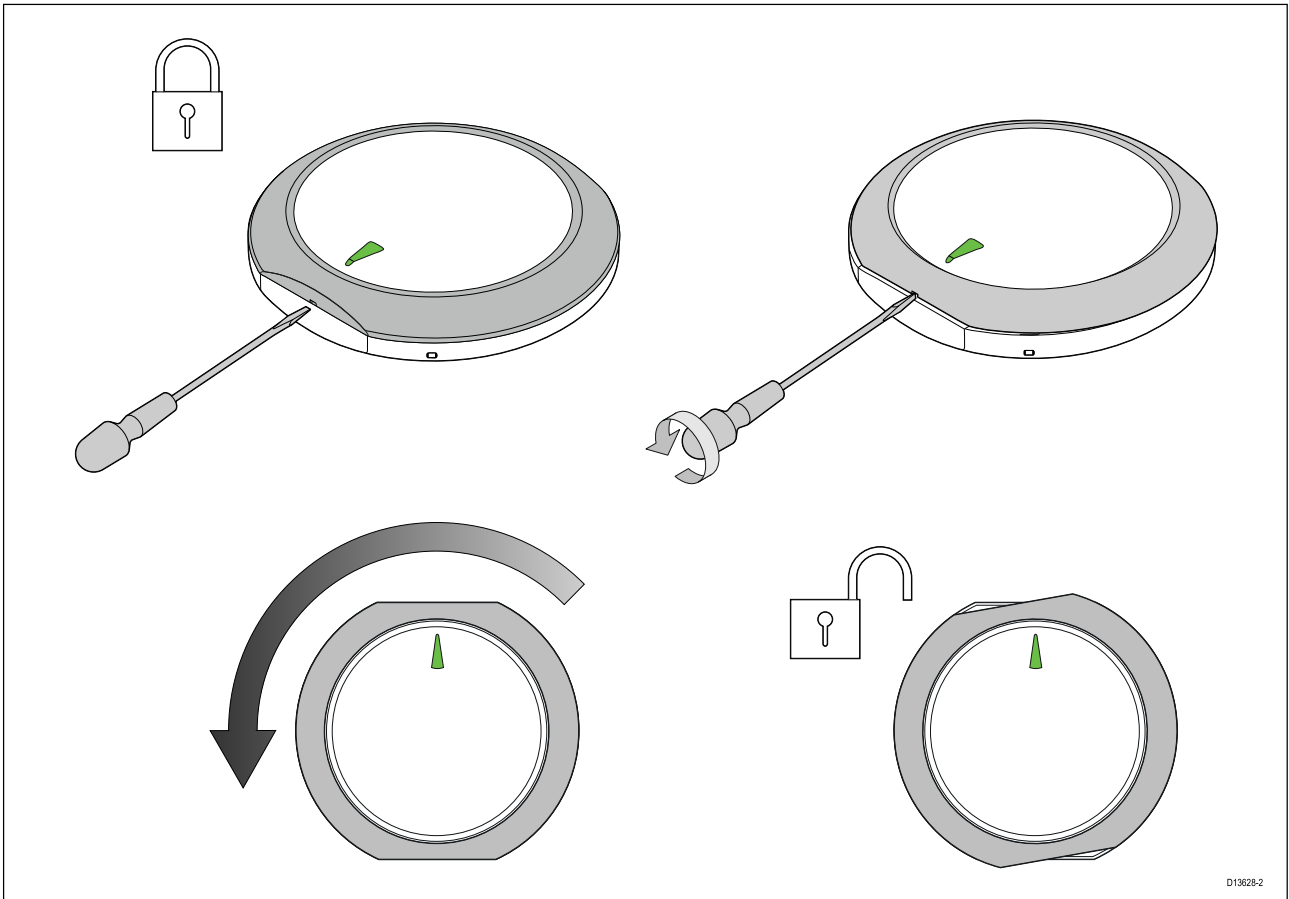

1. Insert the flat of a small flat blade screw driver, or similar tool into the release hole located on the flat edge of the mounting bracket and twist the screw driver 90°, so that there is a small gap between the Mounting trim and Mounting tray.

Important: To help prevent scratching the product, cover the tip of your screw driver with a small piece of insulation tape.

2. With the screw driver in place, twist the mounting trim counter-clockwise approximately 10° and then lift away from the unit.

Chapter 4: Connections

Chapter contents

- 4.1 General cabling guidance
- 4.2 Connections overview
- 4.3 SeaTalkng[®] power supply
- 4.4 System example

4.1 General cabling guidance

Cable types and length

It is important to use cables of the appropriate type and length

- Unless otherwise stated use only standard cables of the correct type, supplied by Raymarine.
- Ensure that any non-Raymarine cables are of the correct quality and gauge. For example, longer power cable runs may require larger wire gauges to minimize voltage drop along the run.

Cable shielding

Ensure that all cables are properly shielded and that the cable shielding is undamaged.

Strain relief

Ensure adequate strain relief is provided. Protect connectors from strain and ensure they will not pull out under extreme sea conditions.

Routing cables

Cables must be routed correctly, to maximize performance and prolong cable life.

- Do NOT bend cables excessively. Wherever possible, ensure a minimum bend diameter (\emptyset) of 200 mm (7.87 in) / minimum bend radius (R) of 100 mm (3.94 in).

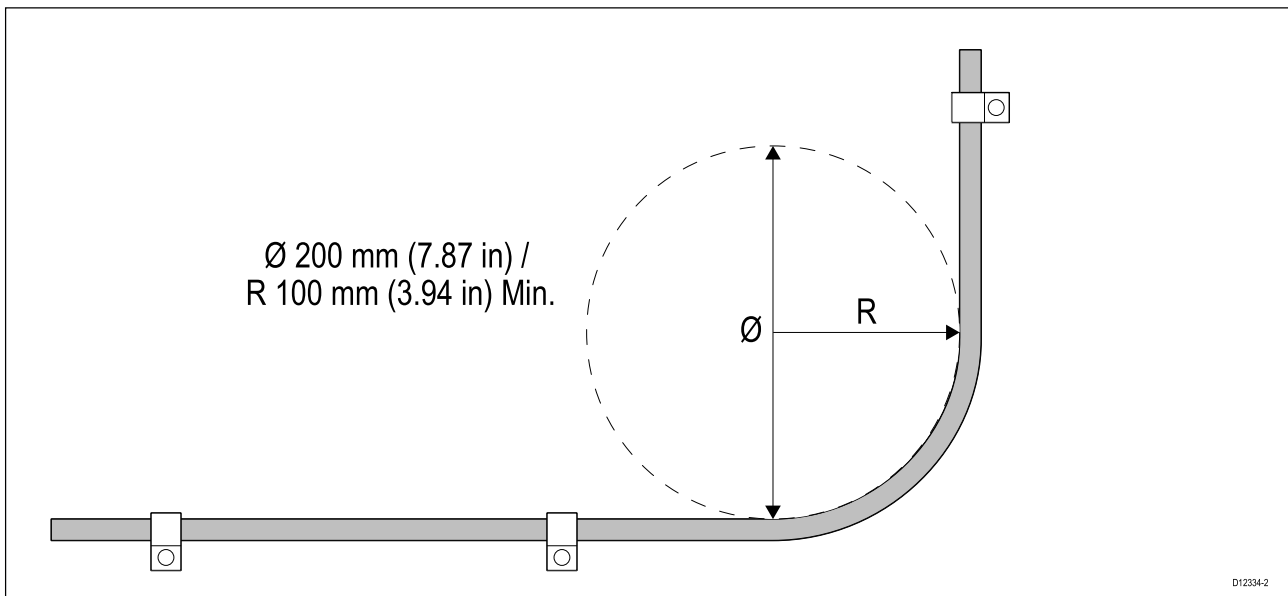

- Protect all cables from physical damage and exposure to heat. Use trunking or conduit where possible. Do NOT run cables through bilges or doorways, or close to moving or hot objects.
- Secure cables in place using cable clips or cable ties. Coil any extra cable and tie it out of the way.
- Where a cable passes through an exposed bulkhead or deckhead, use a suitable watertight feed-through.
- Do NOT run cables near to engines or fluorescent lights.

Always route data cables as far away as possible from:

- other equipment and cables,
- high current carrying AC and DC power lines,
- antennas.

4.2 Connections overview

Your product includes the following connectors.

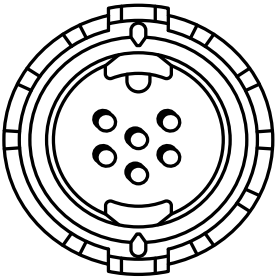
Connector	Qty	Connects to:	Suitable cables
	1	<ol style="list-style-type: none"> 1. SeaTalk^{ng} backbone 2. NMEA 2000 backbone 	<ol style="list-style-type: none"> 1. SeaTalk^{ng} spur cables 2. SeaTalk^{ng} to DeviceNet adaptor cable (A06045)

Connecting SeaTalkng[®] cables

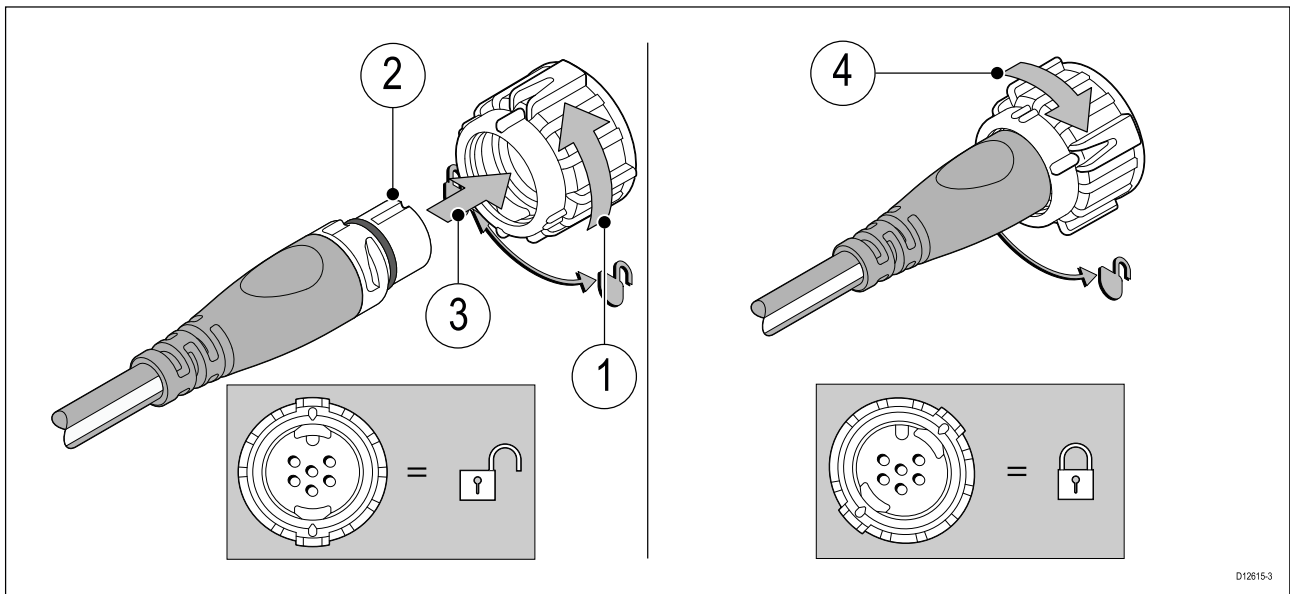

1. Rotate the locking collar so it is in the unlocked position.
2. Ensure the cable's connector is correctly oriented.
3. Fully insert the cable connector.
4. Rotate locking collar clockwise (2 clicks) until it is in the locked position.

SeaTalkng[®] product loading

The number of products that can be connected to a SeaTalkng[®] backbone depends on the power consumption of each product and the physical overall length of the backbone.

SeaTalkng[®] products have a Load Equivalency Number (LEN), which indicates the product's power consumption. The LEN for each product can be found in the product's Technical Specification.

4.3 SeaTalkng[®] power supply

Power is supplied to the product over the SeaTalkng[®] backbone.

A SeaTalkng[®] backbone requires only one 12 V dc power supply, connected to the SeaTalkng[®] backbone. This can be provided by one of the following:

- a battery ⁽¹⁾, via the distribution panel;
- an Autopilot Control Unit (ACU)⁽²⁾;
- an SPX course computer ⁽²⁾;
- for 24 V vessels a 5 amp, regulated, continuous 24 V dc to 12 V dc converter is required.

Note:

- (1) The battery used for starting the vessel's engine(s) should NOT be used to power the SeaTalkng[®] backbone, as this can cause sudden voltage drops when the engines are started.
- (2) The ACU-100, ACU-150 or SPX-5 products cannot be used to power the SeaTalkng[®] backbone.

SeaTalkng[®] power connection point

Small systems

If the backbone length is 60 m (197 ft) or less, the power connection point may be connected at any point in the backbone.

Large systems

If the backbone length is greater than 60 m (197 ft), the power connection point should be connected at a point that creates a balanced current draw from each side of the backbone. The Load Equivalency Number (LEN) is used to determine the power connection point for the system.

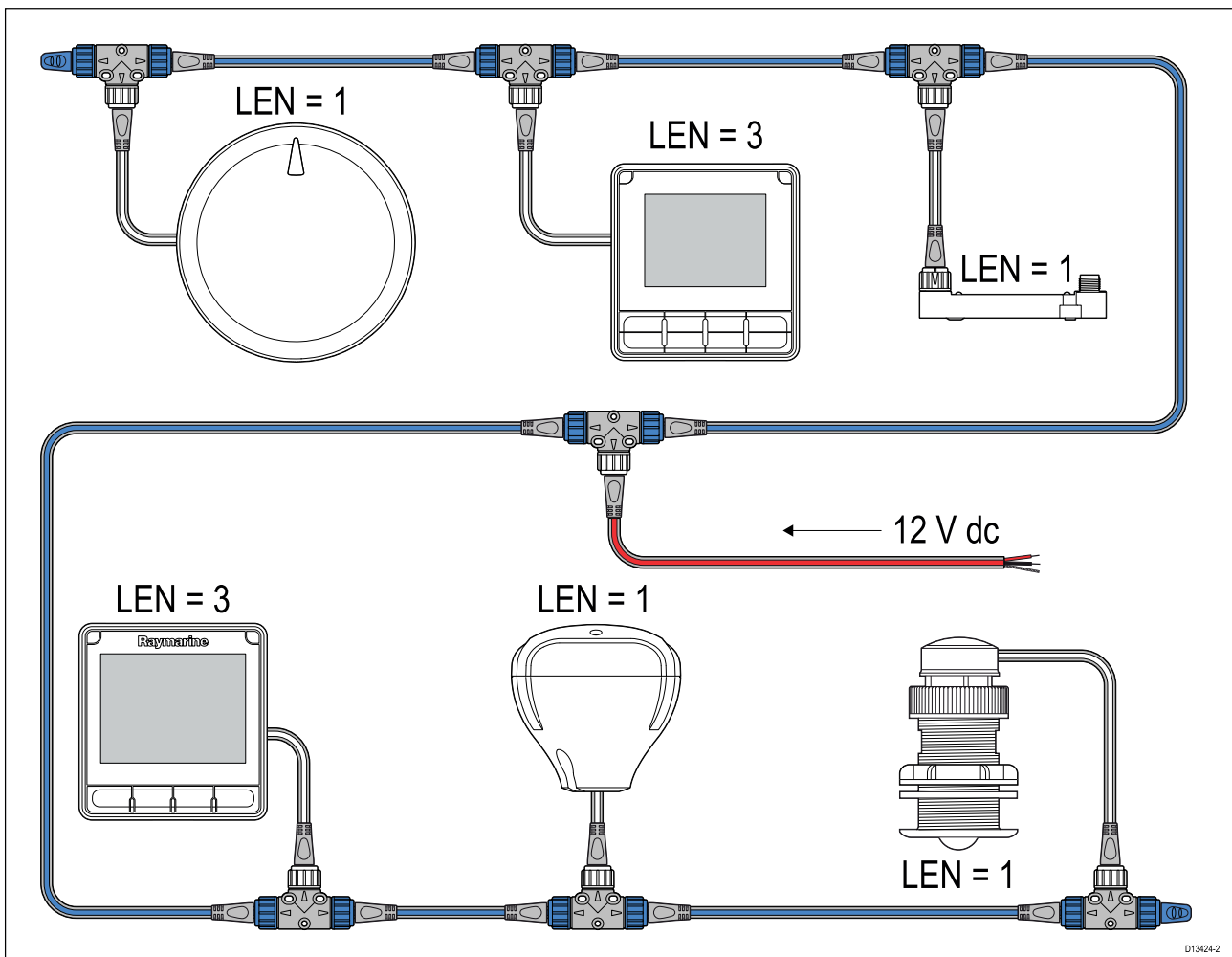

In the example above the system has an overall LEN of 10, so the optimum connection point would be to have 5 LEN either side of the connection point.

In-line fuse and thermal breaker ratings

The SeaTalkng[®] network's power supply requires an in-line fuse or thermal breaker to be fitted.

In-line fuse rating	Thermal breaker rating
5 A	3 A (refer to note below)

Note:

The suitable fuse rating for the thermal breaker is dependent on: 1) How many devices you have connected to your SeaTalkng[®] network; and 2) How many devices are sharing the same thermal breaker that your SeaTalkng[®] network is connected to.

SeaTalkng[®] system loading

The maximum loading / LEN for a SeaTalkng[®] system depends on the length of the backbone.

Loading type	Backbone length	Total LEN
Unbalanced	20 m (66 ft)	40
Unbalanced	40 m (131 ft)	20
Unbalanced	60 m (197 ft)	14
Balanced	60 m (197 ft) or less	100
Balanced	80 m (262 ft)	84
Balanced	100 m (328 ft)	60
Balanced	120 m (394 ft)	50
Balanced	140 m to 160 m (459 ft to 525 ft)	40
Balanced	180 m to 200 m (591 ft to 656 ft)	32

Power distribution – SeaTalkng[®]

Recommendations and best practice.

- Only use approved SeaTalkng[®] power cables. Do NOT use a power cable designed for, or supplied with, a different product.
- See below for more information on implementation for some common power distribution scenarios.

Important:

When planning and wiring, take into consideration other products in your system, some of which (e.g. sonar modules) may place large power demand peaks on the vessel's electrical system.

Note:

The information provided below is for guidance only, to help protect your product. It covers common vessel power arrangements, but does NOT cover every scenario. If you are unsure how to provide the correct level of protection, please consult an authorized Raymarine dealer or a suitably qualified professional marine electrician.

Implementation – direct connection to battery

- SeaTalkng[®] power cables may be connected directly to the vessel's battery, via a suitably rated fuse or breaker.
- You MUST fit a suitably rated fuse or breaker between the red wire and the battery's positive terminal.
- Refer to the inline fuse ratings provided in the product's documentation.
- If you need to extend the length of the power cable, ensure you use suitably rated cable and that sufficient power (12 V dc) is available at the SeaTalkng[®] backbone's power connection.

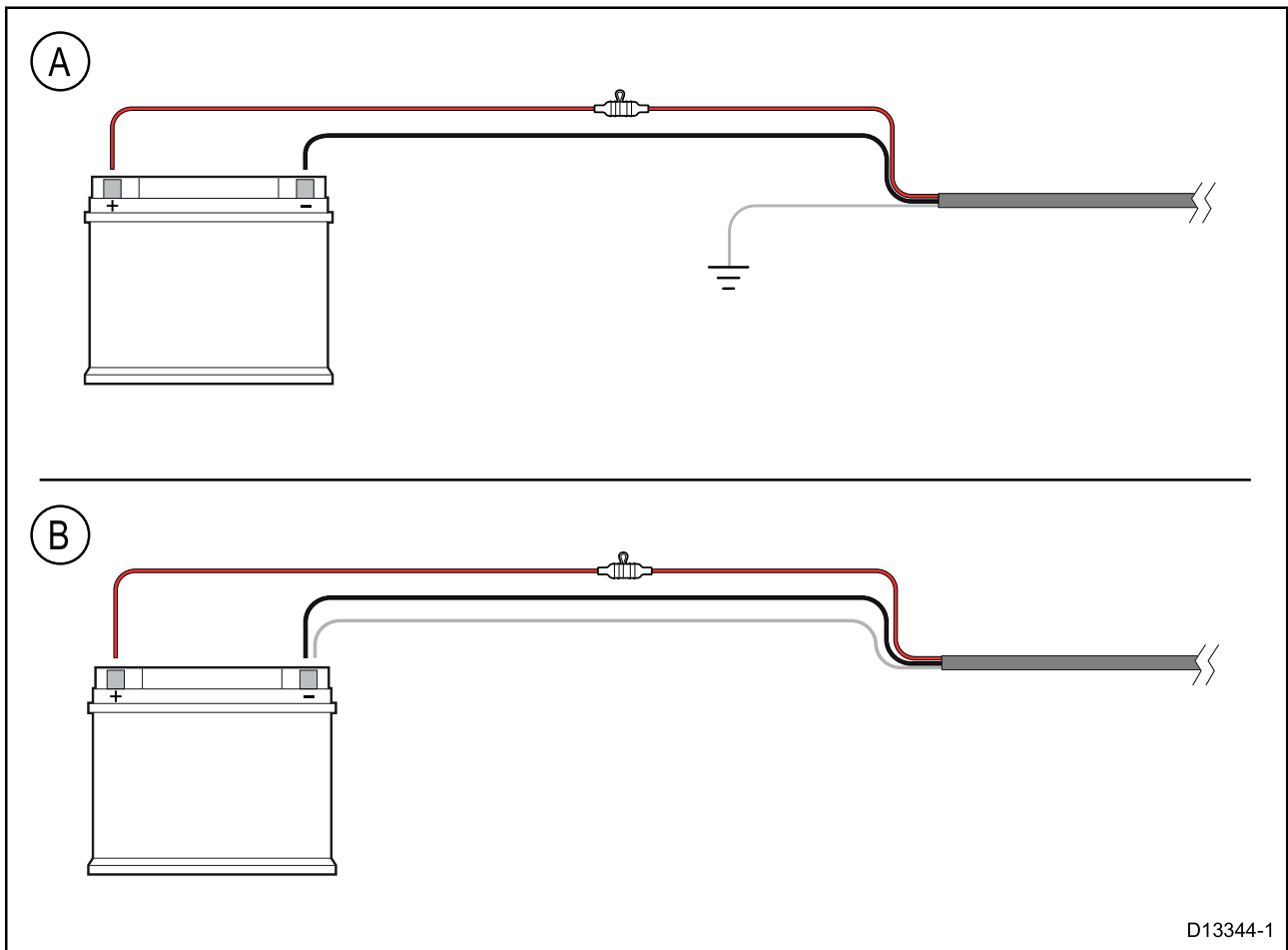

D13344-1

A	Battery connection scenario A: suitable for a vessel with a common RF ground point. In this scenario, if your product's power cable is supplied with a separate drain wire then it should be connected to the vessel's common ground point.
B	Battery connection scenario B: suitable for a vessel without a common grounding point. In this case, if your product's power cable is supplied with a separate drain wire then it should be connected directly to the battery's negative terminal.

Implementation – connection to distribution panel

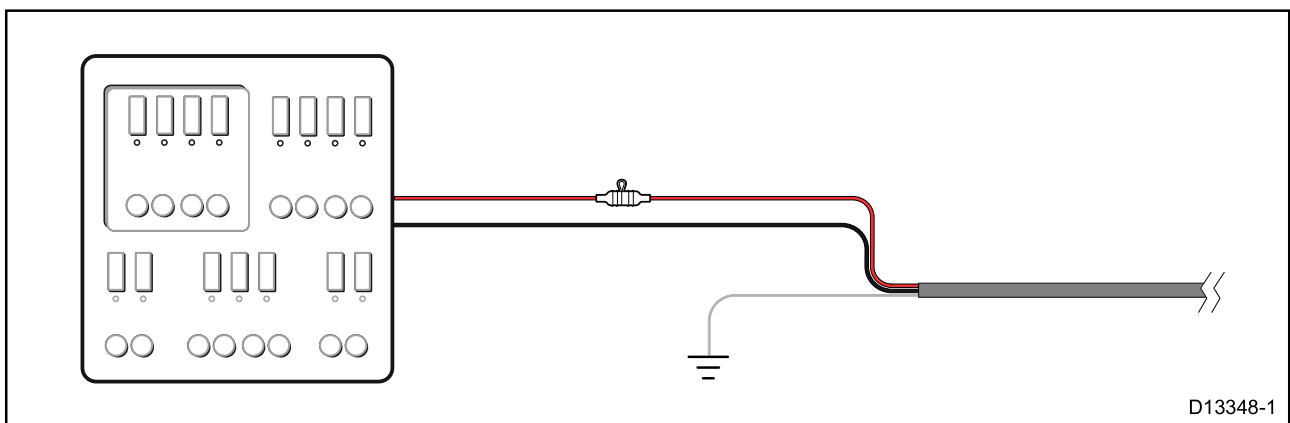

D13348-1

- Alternatively, the SeaTalkng® power cable may be connected to a suitable breaker or switch on the vessel's distribution panel or factory-fitted power distribution point.
- The distribution point should be fed from the vessel's primary power source by 8 AWG (8.36 mm²) cable.
- Ideally, all equipment should be wired to individual suitably-rated thermal breakers or fuses, with appropriate circuit protection. Where this is not possible and more than 1 item of equipment shares a breaker, use individual in-line fuses for each power circuit to provide the necessary protection.
- In all cases, observe the recommended breaker / fuse ratings provided in the product's documentation.

- If you need to extend the length of the power cable, ensure you use suitably rated cable and that sufficient power (12 V dc) is available at the SeaTalkng® backbone's power connection.

Important:

Be aware that the suitable fuse rating for the thermal breaker or fuse is dependent on the number of devices you are connecting.

More information

It is recommended that best practice is observed in all vessel electrical installations, as detailed in the following standards:

- BMEA Code of Practice for Electrical and Electronic Installations in Boats
- NMEA 0400 Installation Standard
- ABYC E-11 AC & DC Electrical Systems on Boats
- ABYC A-31 Battery chargers and Inverters
- ABYC TE-4 Lightning Protection

Sharing a breaker

Where more than 1 piece of equipment shares a breaker you must provide protection for the individual circuits. E.g. by connecting an in-line fuse for each power circuit.

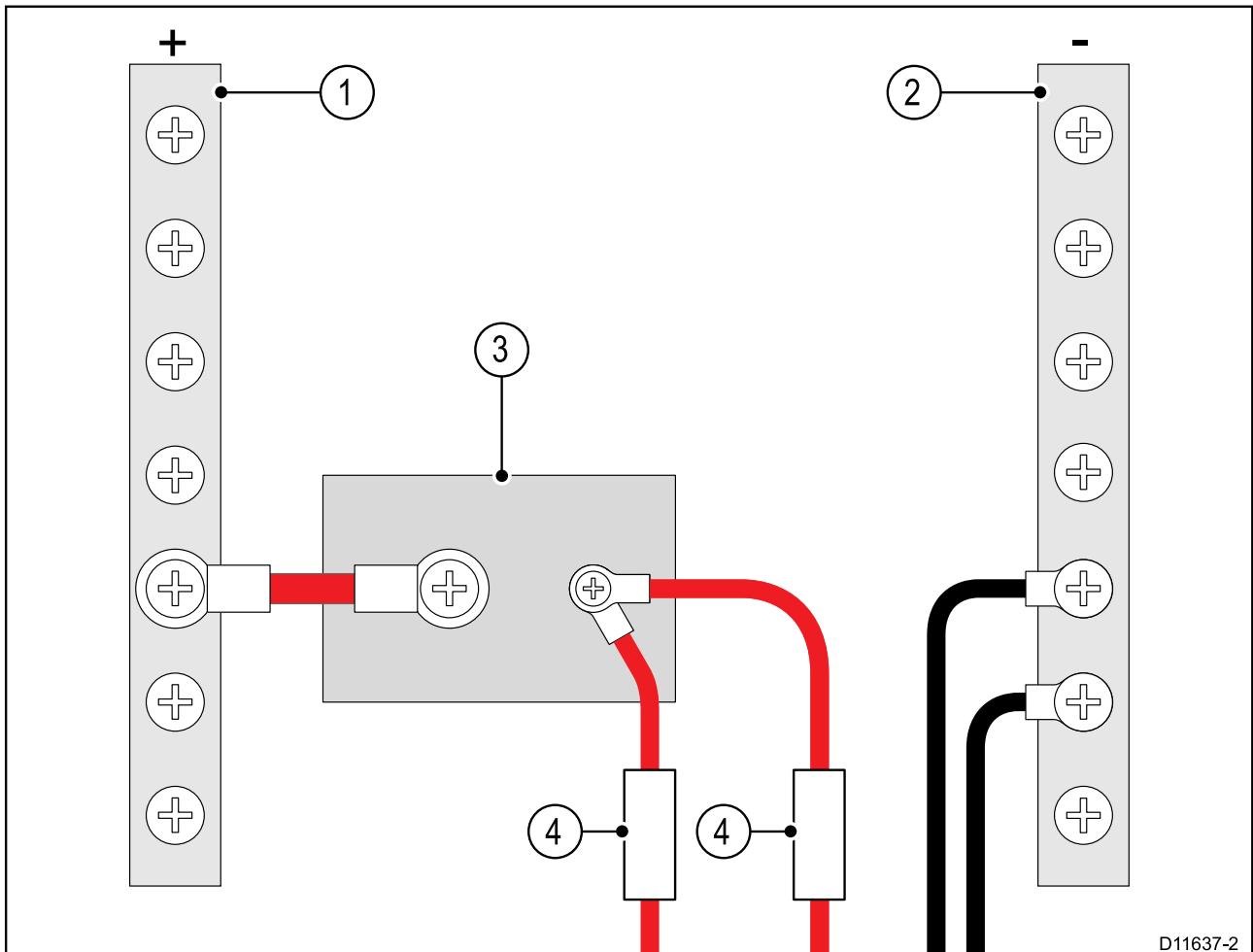

D11637-2

1	Positive (+) bar
2	Negative (-) bar
3	Circuit breaker
4	Fuse

Where possible, connect individual items of equipment to individual circuit breakers. Where this is not possible, use individual in-line fuses to provide the necessary protection.



Warning: Product grounding

Before applying power to this product, ensure it has been correctly grounded, in accordance with the instructions provided.



Warning: Positive ground systems

Do not connect this unit to a system which has positive grounding.

4.4 System example

Below is a typical system example showing the components and connections required to enable ClearCruise™ Augmented Reality on your system.

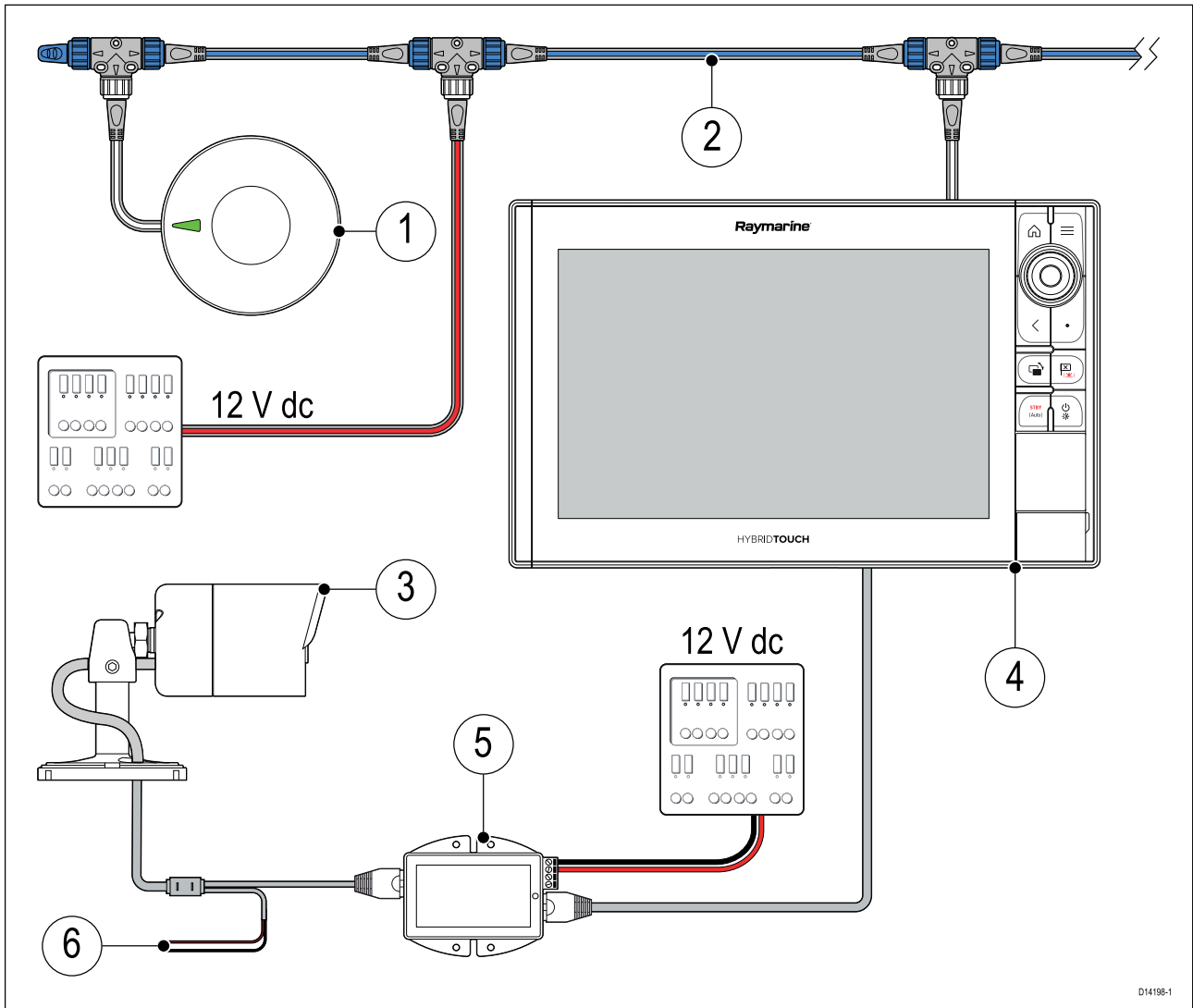

1. AR200.
2. SeaTalkng® backbone (providing 12 V dc power to the AR200).
3. CAM210IP (CAM220IP is also compatible).
4. Axiom LightHouse™ 3 powered MFD (running LH3 version 3.7 or above).
5. Optional PoE injector (providing power to the camera).
6. Alternate power connection for camera (connection required when not using PoE to power the camera).

Chapter 5: System checks and troubleshooting

Chapter contents

- 5.1 Augmented Reality (AR) initial test
- 5.2 AR200 Calibration (Linearization)
- 5.3 GNSS (GPS) check
- 5.4 Troubleshooting

5.1 Augmented Reality (AR) initial test

With the AR200 and a compatible IP camera successfully installed, you can perform an initial check of your Augmented Reality system.

Note:

Your LightHouse™ 3 powered MFD must be running version LH3.7 or above.

1. Select the **Video** app icon from the Homescreen.
2. From the main menu select your augmented reality compatible IP camera.
When you select the relevant camera, in addition to the video feed being displayed ClearCruise™ AR features are also displayed onscreen.

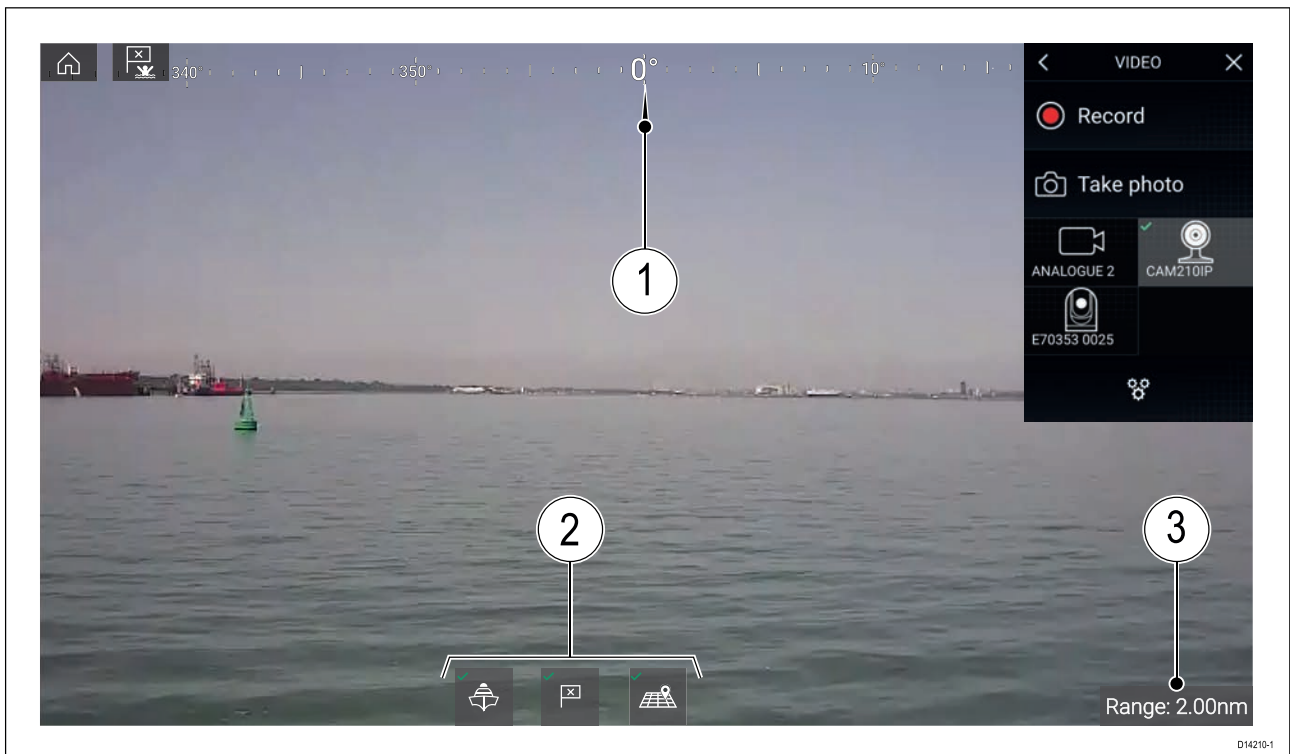

1. Compass bar and heading indicator.
2. AR Object (AIS, Waypoint and Chart object) flag toggle options.
3. AR Object detection range.

5.2 AR200 Calibration (Linearization)

To enable accurate placement of Augmented Reality (AR) flags on the camera's video feed, the AR200's AHRS sensors need to compensate for local and the Earth's magnetic fields. This is achieved using an automatic linearization process. The linearization process starts automatically after your vessel has turned approximately 100°, when travelling at a speed of between 3 to 15 knots. The linearization process requires no user input, however at least a 270° turn is required before linearization can be completed. The duration of the linearization process can be decreased by completing a full 360° turn, when travelling at a speed of between 3 to 15 knots. The linearization process can also be restarted at anytime.



In the Video app the Linearization progress bar is displayed when linearization is in progress, the bar will fill to indicate completeness, the bar will turn Red if the process is paused or otherwise interrupted.

The time taken to complete the linearization process will vary according to the characteristics of the vessel, the AR200's installation location and the levels of magnetic interference present at the time linearization is performed.

Magnetic interference can be caused by object onboard your vessel such as

- Speakers
- Electronic equipment
- Electrical cabling
- Metal bulkhead or hull

Magnetic interference can also be caused by external objects in close proximity to your vessel, such as:

- Metal hulled vessels
- Underwater electrical cables
- Marine pontoons

Magnetic deviation

Magnetic deviation is the error induced in a compass caused by interference from local magnetic fields.

The automatic linearization process results in a deviation value being set for your AR200. If Augmented Reality flags in the Video app are not aligned with their onscreen objects or the compass is out of alignment you should check the AR200's current calibration settings.

AR200 calibration settings

The calibration settings page provides access to the AR200's compass calibration options.

The AR200 calibration page can be accessed using your Data master MFD; from the Homescreen select: **Settings > Network > Data sources > Heading > AR200 > Calibrate.**

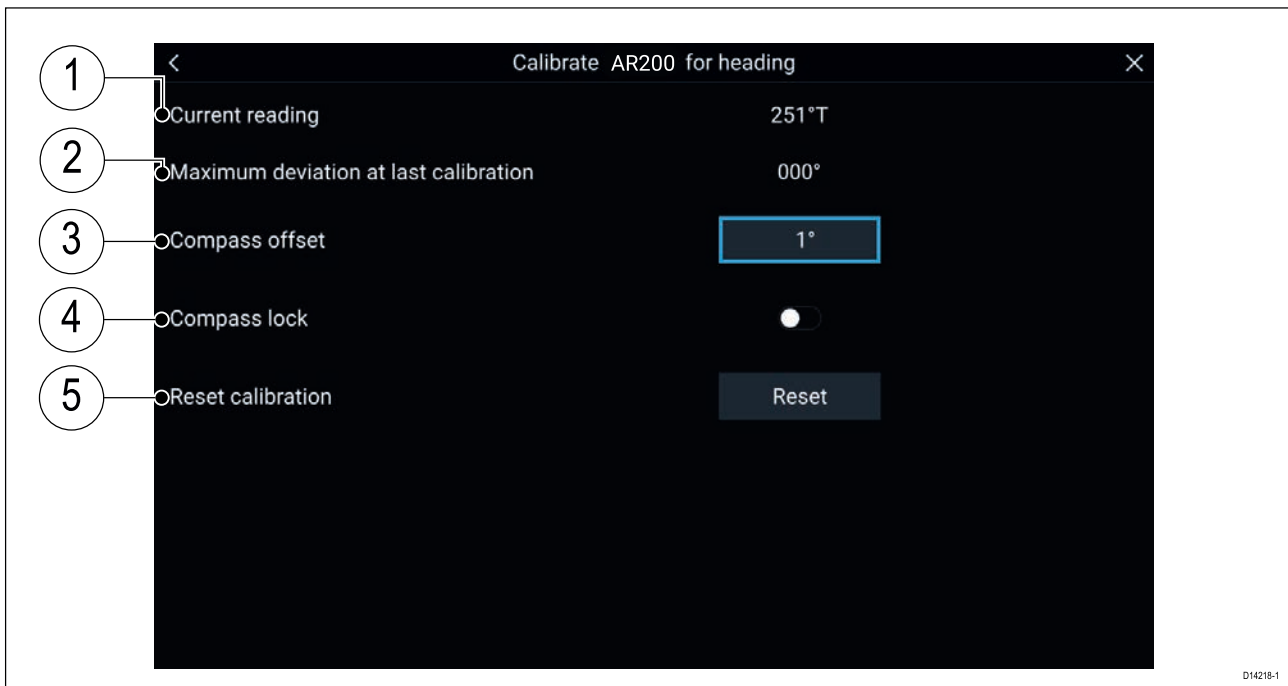

1	<p>Current reading: The current heading reported by the AR200.</p>
2	<p>Maximum deviation at last calibration: The maximum deviation reported during the last linearization process.</p> <div style="border: 1px solid black; padding: 5px;"> <p>Important:</p> <ul style="list-style-type: none"> If the Maximum deviation at last calibration is 45° or above, it is recommended that the AR200 unit is moved and re-installed in a location which is subject to less magnetic interference. </div> <p>Calibration in progress: While linearization is in progress the progress percentage is displayed.</p>
3	<p>Compass offset Once the linearization process has completed, it is possible that the heading value may be slightly out of alignment. This is common where installation space is limited and the AR200 is not properly aligned with your vessel's longitudinal axis. In this case, it is possible to manually adjust the Compass offset.</p>
4	<p>Compass lock When enabled, the Compass lock prevents the continual monitoring and adaptation of the compass linearization process.</p>
5	<p>Reset calibration You can reset your AR200's current linearization settings by selecting Reset calibration</p>

Continual monitoring and adaptation

To ensure optimum performance, after the initial linearization process is complete the unit continues to monitor and adapt the compass linearization to suit current conditions.

If the conditions for linearization are less than ideal, the automatic linearization process temporarily pauses until conditions improve again. The following conditions can cause the linearization process to temporarily pause:

- significant magnetic interference is present
- vessel speed too slow or too fast
- rate-of-turn too slow or too fast

Compass lock

Once you are satisfied with the compass accuracy, you can lock the setting to prevent the autopilot system from completing a further automatic linearization in the future.

This feature is particularly useful for vessels in environments that are exposed to strong magnetic disturbances on a regular basis (such as offshore wind farms or very busy rivers, for example). In these situations it may be desirable to use the Compass lock feature to disable the continuous linearization process, as the magnetic interference may build a heading error over time.

Note: The compass lock may be released at any time, to allow the compass continual monitoring and adaptation to re-commence. This is particularly useful if planning a long voyage. The earth's magnetic field will change significantly from one geographical location to another, and the compass can continually compensate for the changes, ensuring you maintain accurate heading data throughout the voyage.

5.3 GNSS (GPS) check

If you intend to use the AR200 as your systems main GNSS (GPS) receiver then you may need to manually select it from the **Data sources** menu.

The Data sources menu can be accessed from your Data master MFD: **Homescreen > Settings > Network > Data sources > GPS.**

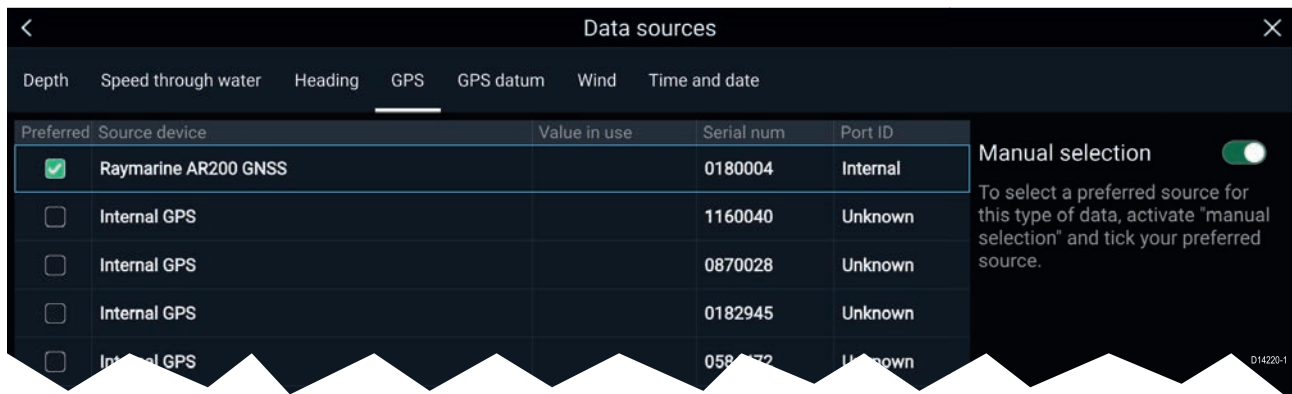

To choose the AR200 as your preferred source for GNSS (GPS) position data, select **Raymarine AR200 GNSS** from the list of devices and then select **Always use this device** from the Pop-over menu. Now the AR200 will always be the preferred source for GNSS (GPS) position data.

Once selected, a tick is placed in the **Preferred** column and the **Manual selection** toggle switch will be enabled. If your AR200 has a position fix then position accuracy is displayed in the **Value in use** column.

When a valid position fix is achieved then your vessel's latitude and longitude is displayed on the Homescreen.

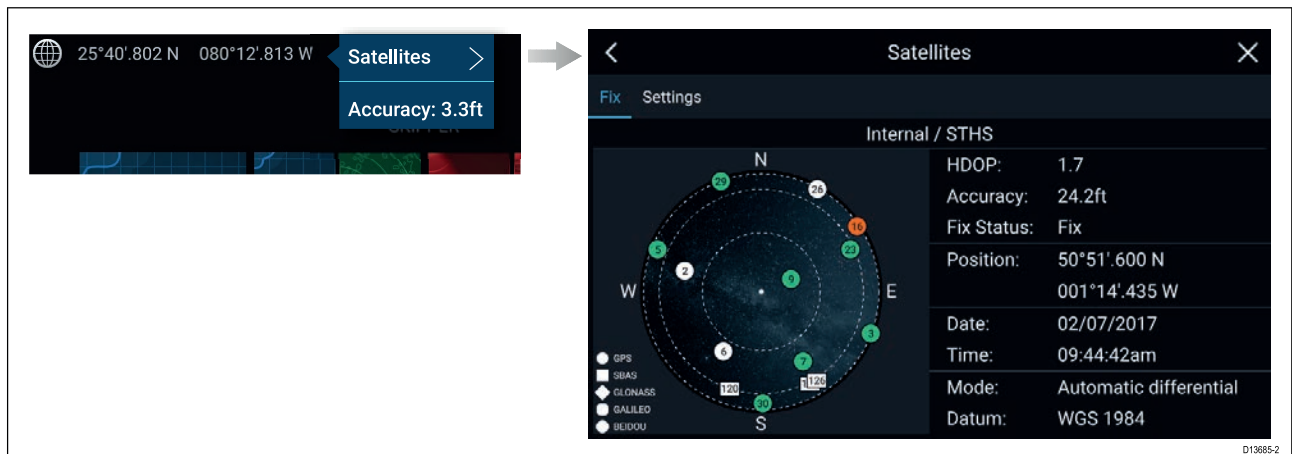

5.4 Troubleshooting

The troubleshooting information provides possible causes and corrective action required for common problems associated with installation and operation of your product.

Before packing and shipping, all Raymarine products are subjected to comprehensive testing and quality assurance programs. If you do experience problems with your product this section will help you to diagnose and correct problems in order to restore normal operation.

If after referring to this section you are still having problems with your product, please refer to the Technical support section of this manual for useful links and Raymarine Product Support contact details.

LED Diagnostics

LED Sequence	Status
<p>Green LED is off once every 15 seconds.</p>	<ul style="list-style-type: none"> All sensors connected and ready. Bus healthy, no communication faults
<p>Green LED flashes on and off once every second.</p>	All sensors are initializing.
<p>Green LED flashes on and off once every 2 seconds.</p>	GNSS (GPS) initializing <div style="border: 1px solid black; padding: 5px; margin-top: 10px;"> <p>Note: Can take up to 5 minutes at first use or after factory reset or software update.</p> </div>
<p>Green LED flashes on and off once every 4 seconds.</p>	Compass linearizing
<p>Red LED flashes on once every 3 seconds.</p>	No GNSS (GPS) signal

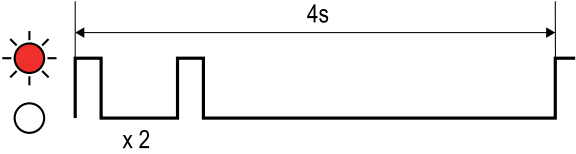
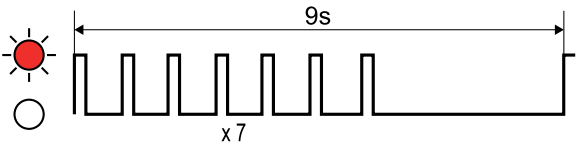
LED Sequence	Status
	Bus not connected / fault
Red LED flashes on twice every 4 seconds.	
	Bus connected but not receiving data
Red LED flashes on 7 times every 9 seconds.	

GNSS troubleshooting

Problems with the GNSS and their possible causes and solutions are described here.

Problem	Possible causes	Possible solutions
"No Fix" GNSS status icon is displayed.	Geographic location or prevailing conditions preventing satellite fix.	Check periodically to see if a fix is obtained in better conditions or another geographic location.
	GNSS connection fault.	Ensure that external GNSS connections and cabling are correct and fault free.
	External GNSS receiver in poor location. For example: <ul style="list-style-type: none">• Below decks.• Close proximity to transmitting equipment such as VHF radio.	Ensure GNSS receiver has a clear view of the sky.
	GNSS installation problem.	Refer to the installation instructions.

Note: A GNSS Status screen is accessible from the display. This provides satellite signal strength and other relevant information.

Augmented Reality (AR) Troubleshooting

AR options not available in Video app

Possible causes	Possible solutions
Wrong camera selected.	Ensure that the correct AR compatible camera has been selected in the Video app menu.
Compatible camera not detected.	<ol style="list-style-type: none"> 1. Ensure your camera is AR compatible. 2. Ensure your camera is correctly installed and networked to your MFD.
AR200 not detected.	<ol style="list-style-type: none"> 1. Ensure your AR200 is connected to the same network as the MFD you are attempting to use AR on. 2. Ensure your AR200 is correctly installed and networked to your MFD.
Incorrect LightHouse™ 3 software version.	Ensure that your MFD is running LightHouse™ 3 version 3.7 or above.
AR options turned off.	<p>The Compass bar, AIS, Waypoint and Chart object flags can be enabled and disabled from the ClearCruise settings page (Video app > Menu > Settings > ClearCruise). Ensure relevant options are enabled.</p> <div style="border: 1px solid black; padding: 5px;"> <p>Note: For AIS flags to be displayed AIS hardware must be connected and operational.</p> </div>

AR flags do not appear directly above onscreen target

Possible causes	Possible solutions
AIS update rate	Depending on the classification of the target's AIS hardware, transmitted position updates may be sent up to 3 minutes apart and therefore the flag may appear up to 3 minutes behind the actual onscreen target.
Camera Field of View (FOV) set incorrectly.	Ensure that the FOV: setting reflects your camera's horizontal FOV. Check your camera's documentation for FOV values.
AR200 interference	If your AR200 is installed in a location which includes a source of magnetic interference large enough to effect AR flag placement then you may need to re-install the AR200 in a different location.
Deviation too high	<ol style="list-style-type: none"> 1. Reset the AR200 calibration by selecting Reset from the AR200 calibration page: Homescreen > Settings > Network > Data sources > Heading > Raymarine AR200 Attitude > Calibrate. 2. If the problem persists then you may need to move your AR200 to a location with less magnetic interference.

Chapter 6: Maintenance

Chapter contents

- 6.1 Service and maintenance
- 6.2 Routine equipment checks
- 6.3 Product cleaning

6.1 Service and maintenance

This product contains no user serviceable components. Please refer all maintenance and repair to authorized Raymarine dealers. Unauthorized repair may affect your warranty.

6.2 Routine equipment checks

It is recommended that you perform the following routine checks, on a regular basis, to ensure the correct and reliable operation of your equipment:

- Examine all cables for signs of damage or wear and tear.
- Check that all cables are securely connected.

6.3 Product cleaning

Best cleaning practices.

When cleaning products:

- Lightly rinse or flush with clean, cool fresh water.
- If your product has a display screen, do NOT wipe the screen with a dry cloth, as this could scratch the screen coating.
- Do NOT use: abrasive, acidic, ammonia, solvent or chemical based cleaning products.
- Do NOT use a jet wash.

Chapter 7: Technical support

Chapter contents

- 7.1 Raymarine product support and servicing
- 7.2 Learning resources

7.1 Raymarine product support and servicing

Raymarine provides a comprehensive product support service, as well as warranty, service, and repairs. You can access these services through the Raymarine website, telephone, and e-mail.

Product information

If you need to request service or support, please have the following information to hand:

- Product name.
- Product identity.
- Serial number.
- Software application version.
- System diagrams.

You can obtain this product information using the menus within your product.

Web support

Please visit the “Support” area of the Raymarine website for:

- **Manuals and Documents**
- **FAQ / Knowledgebase**
- **Technical support forum**
- **Software updates**
- **Worldwide support**

Viewing product information (LightHouse™ 3)

Use the **Settings** menu to view hardware and software information about your MFD, and connected products.

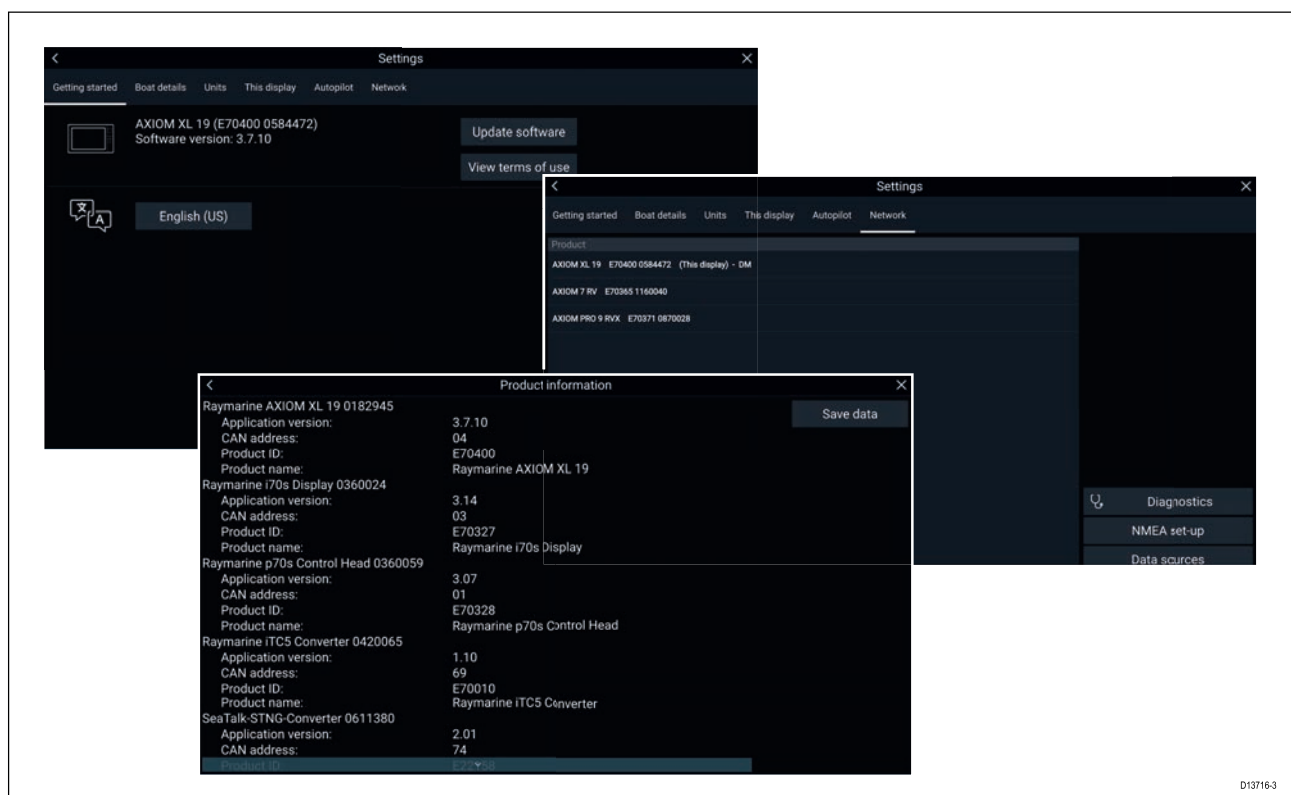

1. Select **Settings**, from the Homescreen.
The **Getting started** tab contains hardware and software information for your MFD.
2. You can view further information about your MFD, or view information about products networked using SeaTalkhs® and SeaTalkng® / NMEA 2000, by selecting the **Network** tab, then:
 - i. to display detailed software information and your MFD’s network IP address, select your MFD from the list.
 - ii. to display detailed diagnostics information for all products, select **Product info** from the **Diagnostics** pop over menu.

Chapter 8: Technical specification

Chapter contents

- 8.1 Technical specification

8.1 Technical specification

Power specification

Nominal supply voltage:	12 V dc (Supplied by the SeaTalkng [®] network.)
Operating voltage range:	9 V dc to 16 V dc (protected up to 32 V dc)
Power consumption:	30 mA Max.
LEN (Load Equivalency Rating):	1

Environmental specification

Operating temperature range:	-25 °C to +55 °C (-13 °F to 131 °F)
Storage temperature range:	-25 °C to +70 °C (-13 °F to 158 °F)
Relative humidity:	93%
Water ingress protection:	IPx6 and IPx7

Conformance specification

EMC Directive:	2014/30/EU
Australia and New Zealand C-Tick compliance:	Level 2
RoHS Directive:	2011/65/EU
WEEE Directive:	2012/19/EU

GNSS receiver specification

Signal acquisition:	Automatic
Channels:	Simultaneously track up to 28 satellites.
Operating frequency:	1574 MHz to 1605 MHz
Update rate:	10 Hz
Sensitivity:	<ul style="list-style-type: none">• Cold start = -147 dBm• Re-acquisition = -160 dBm• Tracking = -164 dBm
GNSS compatibility:	<ul style="list-style-type: none">• GPS• GLONASS• Galileo ready• Beidou ready
Satellite Differential Type (SBAS):	<ul style="list-style-type: none">• WAAS (United States)• EGNOS (Europe)• MSAS (Japan)• GAGAN (India)• QZSS ready (Japan)
Differential acquisition:	Automatic
Position accuracy without SBAS (95%):	< 15 m
Position accuracy with SBAS (95%):	< 5 m
Speed accuracy (95%):	< 0.3 kt
Time to first fix from cold start:	< 2 minutes (< 60 seconds typical)

Time to first fix from hot start:	< 45 seconds
Geodetic Datum:	WGS-84
Antenna:	Internal

AHRS specification

AHRS:	<ul style="list-style-type: none"> • 3-Axis digital accelerometer • 3-Axis digital compass • 3-Axis MEMS Gyro digital angular rate sensor
Magnetic compass accuracy:	<ul style="list-style-type: none"> • Static = $\leq 1^\circ$ RMS • Dynamic = $\leq 3^\circ$ RMS
Pitch, Roll and Yaw accuracy:	$\leq 1^\circ$
Heading, Pitch, Roll and Rate of Turn update rate:	10 Hz

Chapter 9: Spares and accessories

Chapter contents

- 9.1 Accessories
- 9.2 SeaTalkng[®] cables and accessories

9.1 Accessories

The following accessories are available:

Accessories

Item	Part number
Pole/rail mounting adaptor kit	A80370
6 m SeaTalkng white spur cable	A06072
Deck mounting (Clamshell/Riser) kit	A80437

9.2 SeaTalkng® cables and accessories

SeaTalkng® cables and accessories for use with compatible products.

Part No	Description	Notes
T70134	Starter kit	Includes: <ul style="list-style-type: none"> • 1 x 5 Way connector (A06064) • 2 x Backbone terminator (A06031) • 1 x 3 m (9.8 ft) spur cable (A06040) • 1 x Power cable (A06049)
A25062	Backbone Kit	Includes: <ul style="list-style-type: none"> • 2 x 5 m (16.4 ft) Backbone cable (A06036) • 1 x 20 m (65.6 ft) Backbone cable (A06037) • 4 x T-piece (A06028) • 2 x Backbone terminator (A06031) • 1 x Power cable (A06049)
A06038	Spur cable 0.4 m (1.3 ft)	
A06039	Spur cable 1 m (3.3 ft)	
A06040	Spur cable 3 m (9.8 ft)	
A06041	Spur cable 5 m (16.4 ft)	
A06042	Elbow spur cable 0.4 m (1.3 ft)	
A06033	Backbone cable 0.4 m (1.3 ft)	
A06034	Backbone cable 1 m (3.3 ft)	
A06035	Backbone cable 3 m (9.8 ft)	
A06036	Backbone cable 5 m (16.4 ft)	
A06068	Backbone cable 9 m (29.5 ft)	
A06037	Backbone cable 20 m (65.6 ft)	
A06043	SeaTalkng® to bare wire spur cable 1 m (3.3 ft)	
A06044	SeaTalkng® to bare wire spur cable 3 m (9.8 ft)	
A06049	Power cable 1 m (3.3 ft)	
A06077	Right angled connector	90° right angle spur connector.
A06031	Terminator	
A06028	T-piece	Provides 1 x spur connection
A06064	5-way connector block	Provides 3 x spur connections
A06030	Backbone extender	
E22158	SeaTalk to SeaTalkng® converter kit	Allows the connection of SeaTalk devices to a SeaTalkng® system.
A80001	Inline terminator	Provides direct connection of a spur cable to the end of a backbone cable. No T-piece required.
A06032	Spur blanking plug	
R12112	ACU / SPX SeaTalkng® spur cable 0.3 m (1.0 ft)	Connects an SPX course computer or an ACU to a SeaTalkng® backbone.
A06047	SeaTalk (3 pin) to SeaTalkng® adaptor cable 0.4 m (1.3 ft)	

Part No	Description	Notes
A22164	SeaTalk to SeaTalkng [®] spur cable 1 m (3.3 ft)	
A06048	SeaTalk2 (5 pin) to SeaTalkng [®] adaptor cable 0.4 m (1.3 ft)	
A06045	SeaTalkng [®] to DeviceNet (Female) adaptor cable 0.4 m (1.3 ft)	Allows the connection of NMEA 2000 devices to a SeaTalkng [®] system.
A06075	SeaTalkng [®] to DeviceNet (Female) adaptor cable 1 m (3.3 ft)	Allows the connection of NMEA 2000 devices to a SeaTalkng [®] system.
A06046	SeaTalkng [®] to DeviceNet (Male) adaptor cable 1.5 m (4.92 ft)	Allows the connection of NMEA 2000 devices to a SeaTalkng [®] system.
A06076	SeaTalkng [®] to DeviceNet (Male) adaptor cable 1 m (3.3 ft)	Allows the connection of NMEA 2000 devices to a SeaTalkng [®] system.
A06078	SeaTalkng [®] to DeviceNet (Male) adaptor cable 0.1 m (0.33 ft)	Allows the connection of NMEA 2000 devices to a SeaTalkng [®] system.
E05026	DeviceNet (Female) to bare wires adaptor cable (0.4 m (1.3 ft)	Allows the connection of NMEA 2000 devices to a SeaTalkng [®] system.
E05027	DeviceNet (Male) to bare wires adaptor cable (0.4 m (1.3 ft)	Allows the connection of NMEA 2000 devices to a SeaTalkng [®] system.

Appendix A NMEA 2000 PGN support

The unit supports the following NMEA 2000 PGNs.

PGN	Description	Transmit (Tx)	Receive (Rx)
59904	ISO Request		●
59392	ISO Acknowledgement	●	
60160	ISO Transport protocol, data transfer		●
60416	ISO Transport protocol, Connection management — BAM group function	●	●
60928	ISO Address claim	●	●
65240	ISO Commanded address		●
126208	NMEA - Request group function		●
126208	NMEA - Command group function		●
126208	NMEA - Acknowledge group function	●	
126464	Transmission PGN List	●	
126464	Received PGN List	●	
126992	System time	●	
126993	Heartbeat	●	
126996	Product information	●	
126998	Configuration information	●	
127250	Vessel heading	●	
127251	Rate of turn	●	
127257	Attitude	●	
129025	Position, rapid update	●	
129026	COG & SOG rapid update	●	
129027	Position delta high precision	●	
129029	GNSS Position data	●	
129033	Time and date	●	
129044	Datum	●	●
129539	GNSS DOPs	●	
129540	GNSS Satellites in view	●	
129542	GNSS Pseudo range noise statistics	●	
129547	GNSS Pseudo range error statistics	●	