

Raymarine®

P319 B117



Minimize Your Drag

The P319 and B117 feature Airmar's 50/200 kHz, dual-frequency, single-ceramic element in a low-profile housing. Plastic and bronze models are available to accommodate all hull types. The nearly flush design minimizes drag with only 5 mm (2/10") extending outside the hull.



Plastic housing—P319

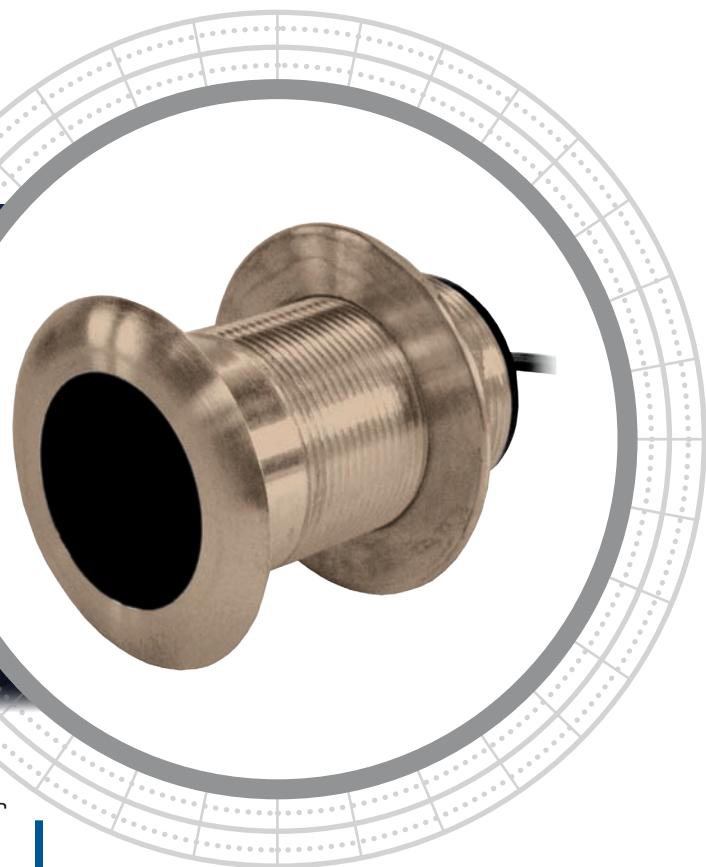

Thru-Hull Low-Profile 600 W

Applications

- Planing hull powerboats
- Sailboats

Features

- Industry standard for low-profile transducers
- Depth only or Depth and temperature
- Good target detail in shallow-water at 200 kHz and good deep-water bottom tracking at 50 kHz
- Right angle cable exit offers low headroom and protection when transducer is stepped on
- Included rubber washer allows tightening of the hull nut to irregular hull surfaces
- Housings are ABYC H-27 compliant
- Optional temperature sensor
- Plastic or bronze housings available
- Boat Size: 8 m (25') and up

P319, B117

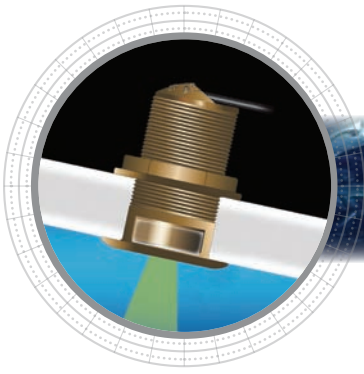

Technical Information

50/200 kHz-A	
Number of Elements and Configuration	○
Beamwidth (@-3 dB)	45° 12°
RMS Power (W)	600 W 600 W
TVR	154 dB 164 dB
RVR	-179 dB -185 dB
FOM	-33 dB -21 dB
Q	28 30
Impedance	200 Ω 375 Ω

MAXIMUM DEPTH RANGE	
50 kHz	200 kHz
235 m to 353 m (800' to 1,200')	118 m to 206 m (400' to 700')

BEAM DIAMETER VS DEPTH		
Depth	50 kHz	200 kHz
9 m (30')	8 m (25')	2 m (6')
30 m (100')	25 m (83')	6 m (21')
122 m (400')	101 m (331')	26 m (84')
305 m (1,000')	252 m (828')	64 m (210')

SPECIFICATIONS
Weight: Plastic—0.6 kg (1.3 lb) Bronze—0.9 kg (2.0 lb)
Hull Deadrise: Up to 8°
Acoustic Window: Urethane
Hole Diameter: 51 mm (2")

