

# Raymarine®

## B60 SS60

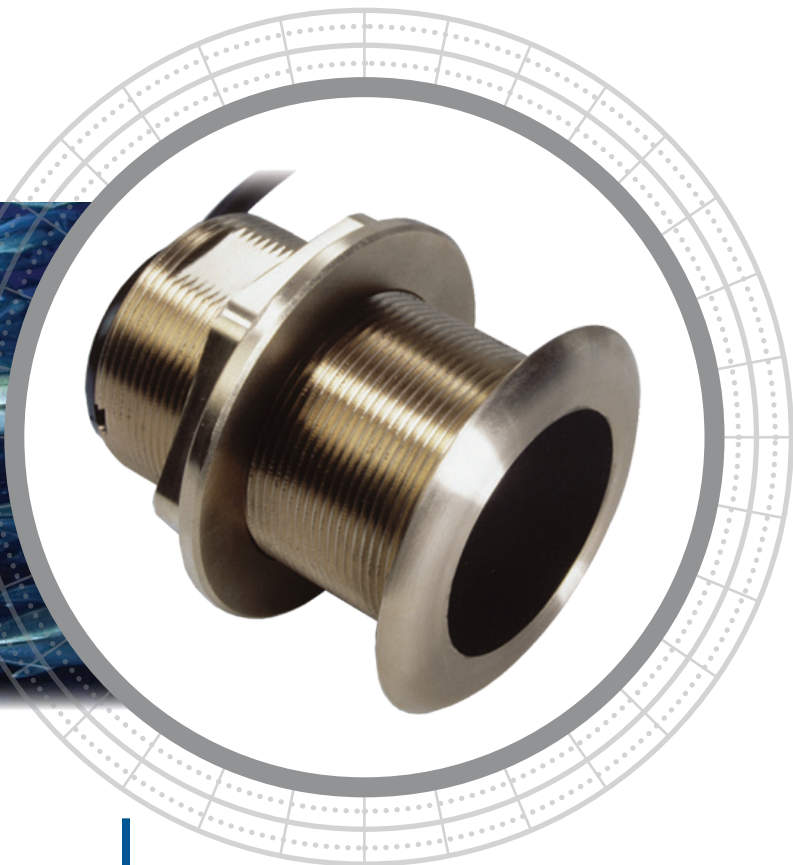

### Coming to You at a New Angle!

The dual-frequency, 50/200 kHz, B60 and SS60, Tilted Element™ transducers are low-profile housings that compensate for hull deadrise. The innovative design tilts the ceramic element inside the transducer housing—a first in the industry!

### Flush With Results

With built-in deadrise compensation, performance is never compromised. This unique design offers professional and recreational boaters advantages similar to using a fairing block—but is installed nearly flush to the hull. On steep-deadrise hulls up to 24°, the beam is aimed straight down, resulting in strong echo returns and accurate depth readings.



Stainless steel housing—SS60

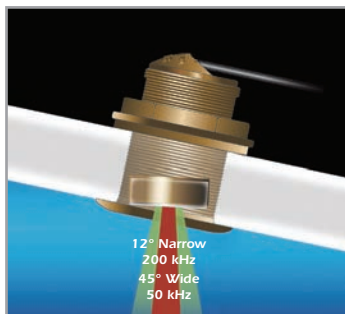

The ceramic element is tilted inside the housing, which compensates for your boat's deadrise. This aims the beam straight toward the bottom, resulting in stronger echo returns and more accurate depth readings.

## Tilted Element™ Thru-Hull 600 W

### Fishing Applications

- Inshore or coastal fishing in shallow to medium depths
- Slow trolling, structure fishing, and drifting
- Deep-water lake fishing

### Features

- Fixed 20° tilted version for 16° to 24° hull deadrise
- Fixed 12° tilted version for 8° to 15° hull deadrise
- Fixed 0° tilted version for 0° to 7° hull deadrise (P319 plastic, B117 bronze, and SS565 stainless steel)
- Engineered for center-console and trailered boats
- Low-profile protrusion below the hull
- No affect on your boat's running performance
- Bronze or stainless steel housings available
- Arrow on cap points toward keel when installed
- Built-in temperature sensor
- Boat Size: Up to 8 m (25')

# B60, SS60

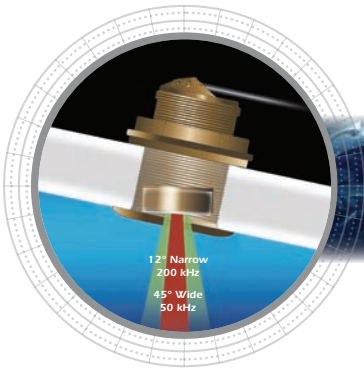

## Technical Information

### 50/200 kHz-A

Number of Elements and Configuration	○	
Beamwidth (@-3 dB)	45°	12°
RMS Power (W)	600 W	600 W
TVR	155 dB	164 dB
RVR	-174 dB	-184 dB
FOM	-31 dB	-21 dB
Q	28	31
Impedance	200 Ω	375 Ω

### MAXIMUM DEPTH RANGE

50 kHz	200 kHz
235 m to 353 m (800' to 1,200')	118 m to 206 m (400' to 700')

### BEAM DIAMETER VS DEPTH

Depth	50 kHz	200 kHz
9 m (30')	8 m (25')	2 m (6')
30 m (100')	25 m (83')	6 m (21')
122 m (400')	101 m (331')	26 m (84')
305 m (1,000')	252 m (828')	64 m (210')

### TRANSDUCER COMPARISON

Model	Power	Rating	Performance Increase
B60 SS60	600 W	Good	Benchmark model for comparison
B164 SS164	1 kW	Better	6 times more sensitive at 50 kHz 2 times more sensitive at 200 kHz
SS264N	1 kW	Best	50 times more sensitive at 50 kHz 13 times more sensitive at 200 kHz

Due to the wide beam of the SS264W, it has been omitted from the table.

### SPECIFICATIONS

**Weight:** 1.4 kg (3 lb)  
**Hull Deadrise:** Up to 24°  
**Acoustic Window:** Urethane

### DIMENSIONS

