

Raymarine®



RAY90/91 VHF

Installation and operation instructions

Trademark and patents notice

Raymarine, Tacktick, Clear Pulse, Truzoom, SeaTalk, SeaTalk^{hs}, SeaTalk^{ng}, and Micronet, are registered or claimed trademarks of Raymarine Belgium.

FLIR, LightHouse, DownVision, SideVision, RealVision, Dragonfly, Quantum, Axiom, Instalert, Infrared Everywhere, The World's Sixth Sense and ClearCruise are registered or claimed trademarks of FLIR Systems, Inc.

All other trademarks, trade names, or company names referenced herein are used for identification only and are the property of their respective owners.

This product is protected by patents, design patents, patents pending, or design patents pending.

Fair Use Statement

You may print no more than three copies of this manual for your own use. You may not make any further copies or distribute or use the manual in any other way including without limitation exploiting the manual commercially or giving or selling copies to third parties.

Contents

Chapter 1 Important information	13
Certified Installation.....	13
FCC.....	13
Compliance Statement (Part 15.19).....	13
FCC Interference Statement (Part 15.105 (b))	14
Innovation, Science and Economic Development Canada (ISED).....	14
Innovation, Sciences et Développement économique Canada (Français)	14
Water ingress	15
Disclaimer	15
Declaration of Conformity.....	15
Product disposal	15
Warranty registration.....	16
Technical accuracy.....	16
Chapter 2 Document and product information	17
2.1 Product documentation.....	18
SeaTalkng® documentation.....	18
User manuals Print Shop	18
Document conventions.....	18
Document illustrations	19
2.2 Product overview	20
2.3 Applicable products.....	21
Required additional components.....	21
Optional wired components	21
Optional wireless components	21
Compatible MFDs	22
Incompatible MFDs.....	23
2.4 Parts supplied	24
2.5 Licensing	26
USA licensing requirements	26
Canada licensing requirements.....	26
Europe and rest of world licensing requirements.....	26
Additional information — Ray90 / Ray91.....	26
Additional information - wireless handset.....	26
Additional information - wireless charging holster.....	27
Additional information - wireless hub	27
Additional information - wireless speaker.....	27
2.6 Obtain MMSI (Maritime Mobile Service Identity) number.....	28
2.7 Automatic Transmitter Identification System (ATIS)	29
2.8 Software updates	30
Checking software versions	30

Ray90/Ray91 software	30
Performing software updates — Raymic handset	30

Chapter 3 Installation 33

3.1 Selecting a location.....	34
General location requirements	34
Antenna mounting and EME exposure	35
3.2 GNSS (GPS) location requirements.....	36
3.3 Wireless product location requirements	37
Wireless location requirements	37
Pre-installation site survey	37
3.4 Product dimensions	39
Product dimensions - Base station	39
Product dimensions - speakers	40
Product dimensions - Wired handset (Raymic)	41
Product dimensions - Wireless hub	42
Product dimensions - Wireless handset and holster.....	43
3.5 Mounting	44
Tools required for installation	44
Mounting the Base station.....	44
Wired and wireless speaker mounting	45
Handset (wired) mounting using the holster.....	46
Pass-through panel kit mounting	47
Mounting the wireless hub	49
Mounting the charging holster for the wireless handset	51

Chapter 4 Cables and connections..... 53

4.1 General cabling guidance	54
Cable types and length.....	54
Routing cables.....	54
Strain relief.....	54
Circuit isolation	54
Cable shielding	54
Connections to other equipment.....	55
Dust caps.....	55
Bare end wire connections.....	55
4.2 Connections overview	56
4.3 Power connection	57
In-line fuse and thermal breaker ratings	57
Grounding.....	57
Power distribution.....	58
4.4 Handset station connection	62
Connecting handsets and cables	62

Handset extension cables	62
4.5 Wired speaker connection	63
4.6 NMEA 2000 / SeaTalkng® connection	64
Connecting SeaTalkng® cables	65
4.7 NMEA 0183 connection	66
4.8 Loud hailer connection	67
4.9 Connecting GNSS (GPS) and VHF antennas	68
4.10 Wireless hub connection	70
4.11 Wireless handset charging holster – power connection	71
In-line fuse and thermal breaker ratings	71
4.12 Wireless handset connections	72
4.13 Wireless speaker – power connection	73
In-line fuse and thermal breaker ratings	73

Chapter 5 Getting started 75

5.1 Handset controls	76
Wireless speaker controls	77
5.2 Powering the Base station	78
Powering the handset.....	78
5.3 Homescreen overview.....	79
Status bar symbols.....	80
Main menu overview.....	82
5.4 Multiple station operation	86
5.5 Adjusting Brightness and Contrast	87
5.6 Shared Brightness.....	88
Enabling Shared Brightness	88
5.7 Initial set up	90
5.8 Selecting a language	91
5.9 Switching on the AIS receiver	92
5.10 Selecting a network type	93
5.11 Entering your MMSI number.....	94
5.12 Entering your ATIS ID	96
Enabling and disabling ATIS mode.....	97
5.13 Changing the radio region.....	98
5.14 Switching between high and low transmit power.....	99
5.15 GNSS (GPS) set up.....	100
Enabling and disabling the internal GNSS (GPS)	100
GNSS data source	100
No position data	100
Entering position manually	100
Selecting (GNSS) GPS information to display	100
Setting time format and offset	101

Chapter 6 Wireless handset stations.....	103
6.1 Wireless handsets	104
Wireless handset charging	104
6.2 Connecting a wireless handset to the hub	106
Checking the Wireless hub's password.....	107
Changing your wireless hub's password	107
Changing the hub's wireless channel.....	107
6.3 Connecting the wireless speaker to the Wireless handset	108
Disconnecting a Wireless speaker.....	108
6.4 Wireless set-up menu options	109
Wireless hub set-up menu options	109
Wireless handset not connected menu	109
Chapter 7 Digital selective calling (DSC)	111
7.1 Digital Selective Calling (DSC).....	112
7.2 Distress calls	114
Making a designated distress call.....	114
Making a Distress call	114
Making a Mayday call	115
Cancelling a distress call before transmission.....	115
Cancelling a distress call after transmission	116
Receiving a distress call.....	117
Ignoring a distress call.....	118
Acknowledging a distress call	118
Manually relaying a distress call	118
Distress relays sent by other stations	118
7.3 Urgency calls.....	120
Making an urgency call.....	120
Receiving an urgency call.....	120
7.4 Safety calls.....	121
Making a safety call	121
Receiving a safety call	121
7.5 Individual (routine) calls	122
Making an Individual call.....	122
Receiving an Individual call.....	122
7.6 Group calls	123
Making a group call	123
Receiving a group call	123
7.7 Position requests	124
Making a position request	124
Responding to a position request.....	124
Setting automatic response to position requests	124

7.8 Phonebook.....	125
Adding a Phonebook entry.....	125
Editing a Phonebook entry	125
Deleting a Phonebook entry.....	125
7.9 Call logs	126
Accessing the call logs	126
7.10 Test calls	127
Making a Test call.....	127
Receiving a test call.....	127
7.11 DSC set-up menu options.....	128

Chapter 8 VHF operations129

8.1 Watch modes.....	130
Setting Watch mode	130
8.2 Scan Mode	131
Setting Scan mode	131
8.3 Priority channels.....	132
Switching between priority channels.....	132
Setting a second priority channel	132
8.4 Sensitivity	133
Switching sensitivity modes.....	133
8.5 Private channels	134
Selecting a private channel set.....	134
8.6 Automatic Transmitter Identification System (ATIS) and Marcom-C mode.....	135
Enabling and disabling ATIS mode.....	135
8.7 AIS receiver	136
Switching AIS on and off.....	136
8.8 Set-up menu options	137
Display Set-up menu.....	138
Shared Brightness menu	138

Chapter 9 Hailer, Fog horn, and Intercom139

9.1 Hailer Fog Intercom menu	140
9.2 Loud Hailer.....	141
Using the hailer.....	141
9.3 Fog horn	142
Using the fog horn in manual mode	142
Using automatic fog horn modes.....	142
Switching off Fog Horn mode	142
9.4 Intercom.....	143
Using the intercom	143
Responding to the intercom	143

Chapter 10 Maintenance	145
10.1 Maintenance.....	146
Routine checks	146
Unit cleaning instructions	146
Chapter 11 Troubleshooting	147
11.1 LED diagnostics — Base station.....	148
11.2 LED diagnostics - Wireless (Active) speaker	149
11.3 Troubleshooting	150
Performing a system reset.....	150
System test	150
11.4 Power up troubleshooting	151
11.5 VHF Radio troubleshooting	153
11.6 GNSS (GPS) troubleshooting.....	154
GNSS (GPS) data output	154
11.7 Wireless troubleshooting	155
Chapter 12 Technical support.....	157
12.1 Raymarine product support and servicing.....	158
12.2 Viewing product information	160
12.3 Learning resources.....	161
Chapter 13 Technical specification	163
13.1 Technical specification — Base station.....	164
13.2 Technical specification — Wired handset (Raymic)	166
13.3 Technical specification - Wired (Passive) speaker.....	167
13.4 Technical specification - Wireless hub	168
13.5 Technical specification - Wireless handset.....	169
13.6 Technical specification - Wireless handset charging holster	170
13.7 Technical specification - Wireless (Active) speaker.....	171
13.8 Radio usage.....	172
Chapter 14 Spares and accessories.....	173
14.1 Ray90 / Ray91 spares.....	174
14.2 Extension cables	175
14.3 Ray90 / Ray91 accessories	176
14.4 SeaTalkng® cables and accessories	177
Appendix A NMEA 0183 sentences	179
Appendix B NMEA 2000 PGN list.....	180
Appendix C MMSI Regulatory bodies and application submissions.....	181
Appendix D VHF Channels	182
Appendix E Phonetic alphabet	193

Chapter 1: Important information

Certified Installation

Raymarine recommends certified installation by a Raymarine approved installer. A certified installation qualifies for enhanced product warranty benefits. Contact your Raymarine dealer for further details, and refer to the separate warranty document packed with your product.



Warning: Product installation and operation

- This product must be installed and operated in accordance with the instructions provided. Failure to do so could result in personal injury, damage to your vessel and/or poor product performance.
- Raymarine recommends certified installation by a Raymarine approved installer. A certified installation qualifies for enhanced product warranty benefits. Contact your Raymarine dealer for further details, and refer to the separate warranty document packed with your product.



Warning: Potential ignition source

This product is NOT approved for use in hazardous/flammable atmospheres. Do NOT install in a hazardous/flammable atmosphere (such as in an engine room or near fuel tanks).



Warning: 12 Volt dc only

This product must only be connected to a **12 volt dc** power source.



Warning: Chassis grounding

Do NOT ground this product using the chassis ground terminal.
Grounding this product to a vessel's RF ground may cause galvanic corrosion.



Warning: VHF Antenna isolation

To prevent galvanic corrosion your VHF antenna must be isolated from any vessel metalwork using a suitable, insulated (e.g. plastic) mounting bracket.



Warning: Positive ground systems

Do not connect this unit to a system which has positive grounding.



Warning: Switch off power supply

Ensure the vessel's power supply is switched OFF before starting to install this product. Do NOT connect or disconnect equipment with the power switched on, unless instructed in this document.

FCC



Warning: FCC Warning (Part 15.21)

Changes or modifications to this equipment not expressly approved in writing by Raymarine Incorporated could violate compliance with FCC rules and void the user's authority to operate the equipment.

Compliance Statement (Part 15.19)

This device complies with Part 15 of the FCC Rules. Operation is subject to the following two conditions:

1. This device may not cause harmful interference.
2. This device must accept any interference received, including interference that may cause undesired operation.

FCC Interference Statement (Part 15.105 (b))

This equipment has been tested and found to comply with the limits for a Class B digital device, pursuant to Part 15 of the FCC Rules.

These limits are designed to provide reasonable protection against harmful interference in a residential installation. This equipment generates, uses, and can radiate radio frequency energy and, if not installed and used in accordance with the instructions, may cause harmful interference to radio communications. However, there is no guarantee that interference will not occur in a particular installation. If this equipment does cause harmful interference to radio or television reception, which can be determined by turning the equipment off and on, the user is encouraged to try to correct the interference by one of the following measures:

1. Reorient or relocate the receiving antenna.
2. Increase the separation between the equipment and receiver.
3. Connect the equipment into an outlet on a circuit different from that to which the receiver is connected.
4. Consult the dealer or an experienced radio / TV technician for help.

Innovation, Science and Economic Development Canada (ISED)

This device complies with License-exempt RSS standard(s).

Operation is subject to the following two conditions:

1. This device may not cause interference; and
2. This device must accept any interference, including interference that may cause undesired operation of the device.

This Class B digital apparatus complies with Canadian ICES-003.

Innovation, Sciences et Développement économique Canada (Français)

Cet appareil est conforme aux normes d'exemption de licence RSS.

Son fonctionnement est soumis aux deux conditions suivantes:

1. cet appareil ne doit pas causer d'interférence, et
2. cet appareil doit accepter toute interférence, notamment les interférences qui peuvent affecter son fonctionnement.

Cet appareil numérique de la classe B est conforme à la norme NMB-003 du Canada.



Warning: Maximum Permissible Exposure

For optimal radio performance and minimal human exposure to Radio Frequency (RF) electromagnetic energy, you must ensure that the antenna is:

- connected to the radio before transmitting
- located where it will be away from people
- located at least 1.8 meters (5.9 feet) from the radio's main unit

Failure to observe these guidelines may expose those within the Maximum Permissible Exposure (MPE) radius to RF radiation absorption that exceeds the FCC MPE limit. It is the radio operator's responsibility to ensure that no person comes within this radius.

Caution: Perform regular radio checks

Perform regular radio checks when using your vessel, as recommended in radio training and certification schemes and radio equipment rules of use.

Chapter 2: Document and product information

Chapter contents

- [2.1 Product documentation on page 18](#)
- [2.2 Product overview on page 20](#)
- [2.3 Applicable products on page 21](#)
- [2.4 Parts supplied on page 24](#)
- [2.5 Licensing on page 26](#)
- [2.6 Obtain MMSI \(Maritime Mobile Service Identity\) number on page 28](#)
- [2.7 Automatic Transmitter Identification System \(ATIS\) on page 29](#)
- [2.8 Software updates on page 30](#)

2.1 Product documentation

The following documentation is applicable to your product:

Description	Part number
Installation and operation instructions	81377
Ray90 / Ray91 mounting template	87329
Wired / Wireless speaker mounting template	87358
Wireless hub mounting template	87331
Wireless handset charging holster mounting template	87357
Wired handset holster mounting template	87359

SeaTalkng[®] documentation

Description	Part number
SeaTalkng[®] reference manual Planning and connection of systems based around the SeaTalkng [®] network.	81300
SeaTalk — SeaTalkng[®] converter installation instructions Installation and connection of the SeaTalk — SeaTalkng [®] converter.	87121

User manuals Print Shop

Raymarine provides a Print Shop service, enabling you to purchase a high-quality, professionally-printed manual for your Raymarine product.

Printed manuals are ideal for keeping onboard your vessel, as a useful source of reference whenever you need assistance with your Raymarine product.

Note:

- Accepted methods of payment for printed manuals are credit cards and PayPal.
- Printed manuals can be shipped worldwide.
- Further manuals will be added to the Print Shop over the coming months for both new and legacy products.
- Raymarine user manuals are also available to download free-of-charge from the Raymarine website, in the popular PDF format. These PDF files can be viewed on a PC / laptop, tablet, smartphone, or on the latest generation of Raymarine multifunction displays.

Document conventions

The following conventions are used throughout this document.

Procedures for performing specific tasks using the product's user interface.

The term "Select" is used to refer to the action of:

- Touchscreen control — using your finger to select a menu option or item on the screen.
- Physical buttons — Highlighting an item using the navigational controls and confirming the selection by pressing the **OK** button.

Examples:

- Select **Ok** to confirm your selection.

- Select **Set-up**

Procedures for navigating menu hierarchies.

Menu hierarchies are used in this document to provide a quick summary on how to access a particular function or menu option.

Examples:

- The internal sonar module is turned off from the Fishfinder application menu: **Menu > Set-up > Sounder Set-up > Internal Sounder.**
- The internal GPS can be switched off from the Set-up menu: **Menu > Set-up > GPS Set-up > Internal GPS.**

Document illustrations

Your product and if applicable, its user interface may differ slightly from that shown in the illustrations in this document, depending on product variant and date of manufacture.

All images are provided for illustration purposes only.

2.2 Product overview

The Ray90 and Ray91 are 12 V dc, Class D Digital Selective Calling (DSC) VHF radios. DSC enables you to make and receive calls to a specific radio, and to transmit and receive position information to and from a selected radio. DSC also allows transmission of a distress alert, to all radios within range, at the touch of a button. Once a DSC request is sent and acknowledged voice communication is carried out on the channel chosen by the caller. The radio can transmit and receive on all available US, Canadian, International and Private marine VHF channels.

The Ray90 includes the following features:

- Built-in GNSS (GPS) receiver requiring an external antenna.
- Up to 2 fully functioning wired handset stations with wired speaker connections.
- Connect to a wireless hub to add up to 3 fully functioning wireless handset stations with wireless speaker connections.
- With an optional loud hailer connected the radio can also be used as a fog horn or loud public address (PA) system.

The Ray91 includes the same features as the Ray90 and also has a built-in AIS receiver.

2.3 Applicable products

This document is applicable to the following products:

Name	Part number	
Ray90	E70492	<ul style="list-style-type: none"> Supplied with a wired handset and speaker.
Ray91	E70493	<ul style="list-style-type: none"> Includes built-in AIS receiver. Supplied with a wired handset and speaker.

Required additional components

Your product requires a VHF antenna to function as a radio. If you intend to use the radio's internal GNSS (GPS) receiver then you will also require a GNSS (GPS) passive antenna to be connected.

Part number	Description
N/A	3 rd Party 50 ohm VHF antenna
A80288	Passive GNSS (GPS) antenna

Optional wired components

The following optional components can be purchased to create a second wired handset station.

Part number	Description
A80289	Wired handset <div style="border: 1px solid black; padding: 5px; margin-top: 10px;"> <p>Note:</p> <ul style="list-style-type: none"> To be compatible with the Ray90 / Ray91, the Wired handset must be running software version V1.23 or greater. A passive speaker can be connected to the handset using adaptor cable A80297. </div>
A80542	Wired speaker (passive)

Extension cables

The following extension cables are available:

Part number	Description
A80291	Wired handset extension cable 5 m (16.4 ft)
A80292	Wired handset extension cable 10 m (32.8 ft)
A80290	Wired handset extension cable 15 m (49.2 ft)
A80297	Wired handset adaptor cable with male RCA audio (400 mm 1.3 ft)

Optional wireless components

Your radio supports connection of wireless handsets and speakers via a wireless hub, enabling creation of additional fully functional, wireless handset stations.

The following wireless components are available:

Part number	Component	Description
A80540	Wireless hub	Allows connection of up to 3 Wireless handsets.
A80544	Wireless handset (including holster)	Wireless handset with inductive charging and wireless speaker connection.
A80543	Wireless speaker (Active)	Connects to the Wireless handset.

Compatible MFDs

Your radio can be integrated with compatible MFDs, enabling DSC distress message information and position data on your MFD screen.

Compatible LightHouse™ 3 MFDs

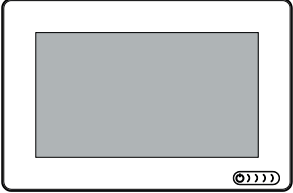
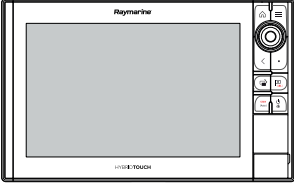
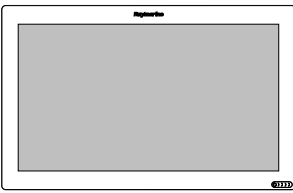
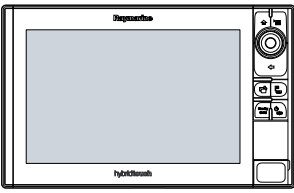
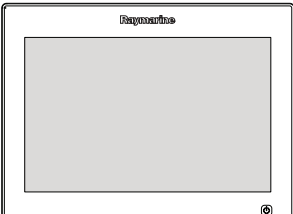
	Axiom™		Axiom™ Pro
	Axiom™ XL		eS Series
	gS Series		

Compatible LightHouse™ 2 MFDs

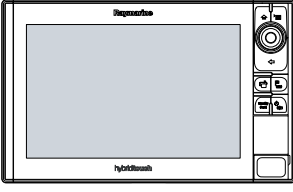
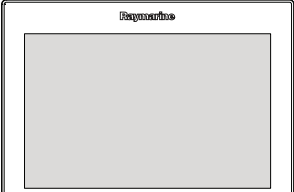
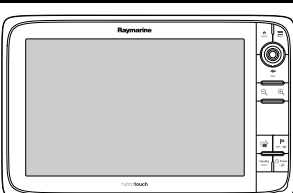
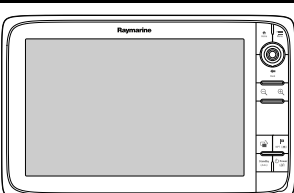
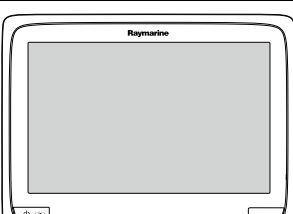
	eS Series		gS Series
	e Series		c Series
	a Series		

Compatible Legacy MFDs

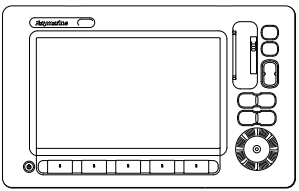
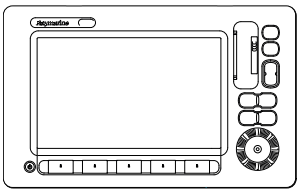
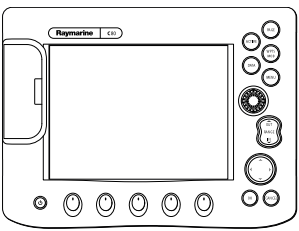
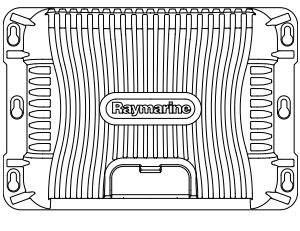
	E-Series Widescreen		C-Series Widescreen
	E-Series Classic		G-Series

Incompatible MFDs

This product is NOT compatible with the following legacy Raymarine multifunction displays.

Legacy MFDs

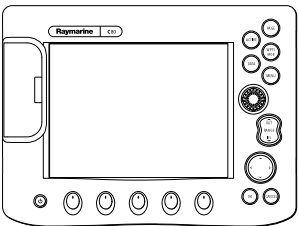
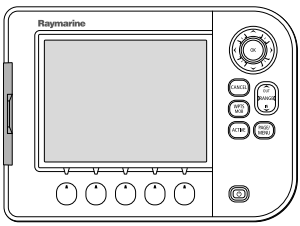
	C-Series Classic		A-Series Classic
--	------------------	---	------------------

2.4 Parts supplied

The following parts are supplied with your product. Please ensure your box contents are correct before proceeding with the installation.

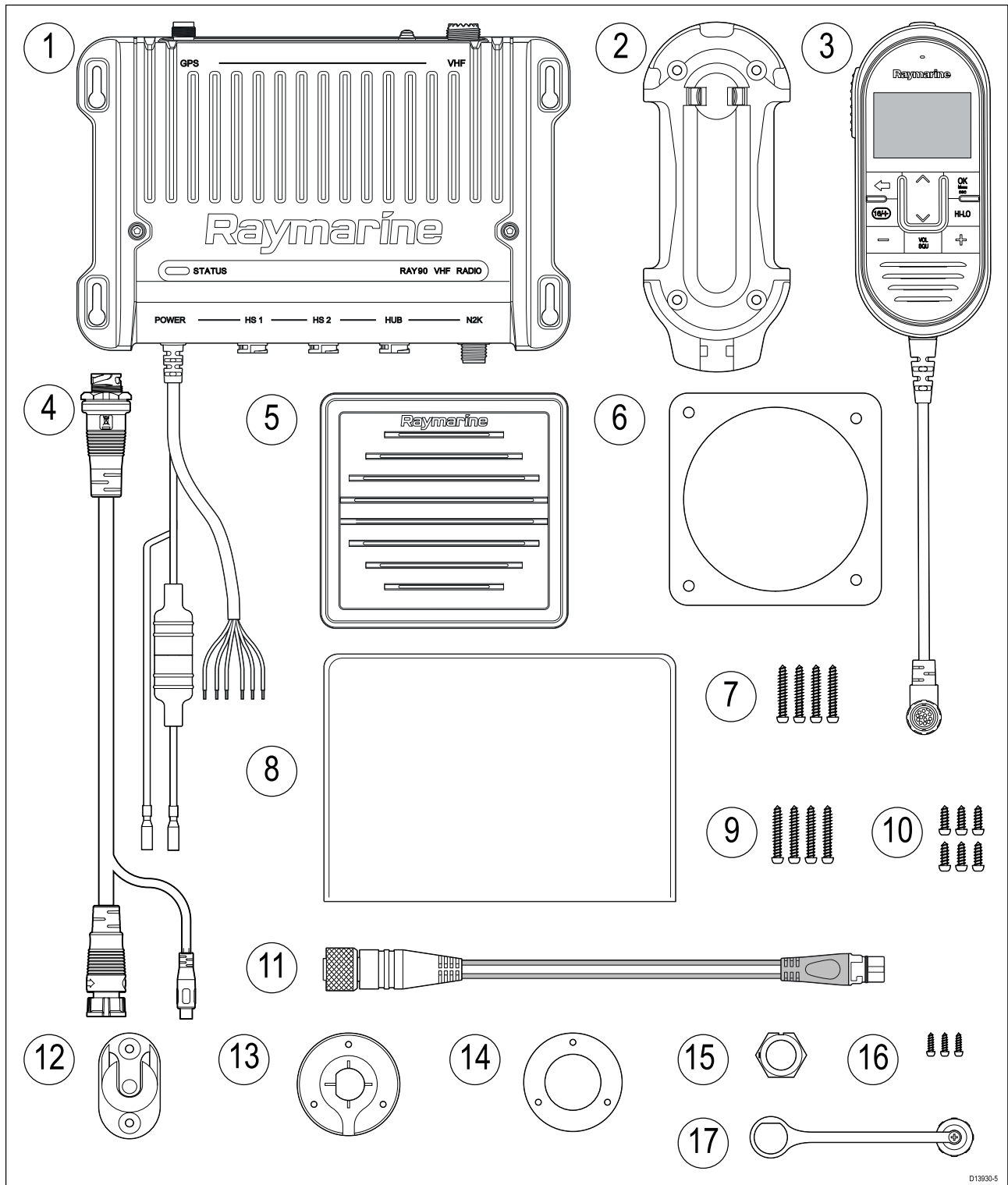

1. Ray90 / Ray91 VHF DSC Radio base station (including fitted power and data cable).
2. Wired handset holster.
3. Wired handset.
4. Wired handset adaptor cable with RCA Audio 400 mm (1.3 ft).
5. Passive speaker and bezel.
6. Passive speaker mounting gasket.
7. 4 x M4x25 screws (for wired speaker mounting).
8. Documentation.

9. 4 x M4x35 screws (For base station mounting).
10. 6 x M4x12 screws (For Handset holster and hook plate mounting).
11. DeviceNet to SeaTalkng[®] 1 m (3.28 ft) adaptor cable.
12. Handset hook plate.
13. Through panel cable mounting plate.
14. Through panel cable mounting plate gasket.
15. Through panel cable mounting nut.
16. Through panel cable mounting plate screws x 3.
17. Through panel cable mounting dust cap.

2.5 Licensing

Prior to using this product please check your national requirements for both operator and equipment licensing.

USA licensing requirements

FCC station license requirement

An FCC Ship Radio Station License and Call Sign are not required for most recreational vessels travelling in US waters. However, you must obtain a license if your vessel travels to foreign ports.

Ships that use MF/HF single side-band radio, satellite communications, or telegraphy must be licensed by the FCC. You can obtain a Station License by filing FCC Form 605.

Canada licensing requirements

You do not need a license to operate this product within the sovereign waters of Canada or the United States of America (USA).

You will need a license to operate this radio outside of Canada or the USA.

Europe and rest of world licensing requirements

Regulations in some areas require that an Operator's license is obtained before operating a VHF radio. It is your responsibility to determine whether a license is required in your area before operating this equipment.

Additional information — Ray90 / Ray91

The following additional information is required for completing a license application in Canada and the USA.

ISED ID:	4069B-RAY90D
FCC ID	PJ5-RAY90
FCC Type accepted	Parts 2, 15 and 80
Output power	1 watt (low) and 25 watt (high)
Modulation	FM
Frequency range	155.500 MHz to 163.275 MHz

Additional information - wireless handset

ISED ID:	4069B-RAY90W
FCC ID:	PJ5-RAY90W
FCC type accepted	Parts, 2, 15 and 80
Output power	1. 19 dBm 2. 4dBm
Modulation	1. MIMO-OFDM/DSSS/CCK 2. GFSK
Frequency	1. 2412MHz to 2472MHz 2. 2412MHz to 2472MHz

Note:

ISED previously IC (Industry Canada)

Additional information - wireless charging holster

ISED ID:	4069B-RAYCGR
FCC ID:	PJ5-RAYCGR
FCC type accepted	Parts, 2, 15 and 80
Output power	5 watt
Modulation	QI
Frequency	110KHz to 205KHz

Note:

ISED previously IC (Industry Canada)

Additional information - wireless hub

ISED ID:	4069B-RAYHUB
FCC ID:	PJ5-RAYHUB
FCC type accepted	Parts, 2, 15 and 80
Output power	19 dbm
Modulation	MIMO-OFDM/DSSS/CCK
Frequency	2412-2472MHz

Note:

ISED previously IC (Industry Canada)

Additional information - wireless speaker

ISED ID:	4069B-RAYSPK
FCC ID:	PJ5-RAYSPK
FCC type accepted	Parts, 2, 15 and 80
Output power	4 dbm
Modulation	GFSK
Frequency	2412MHz to 2472MHz

Note:

ISED previously IC (Industry Canada)

2.6 Obtain MMSI (Maritime Mobile Service Identity) number

Before commencing installation ensure you have obtained a MMSI number for your vessel.

A MMSI is a 9 digit number which is sent over a radio frequency channel in order to identify the originating vessel/station. If your vessel already has a MMSI number (used for a VHF DSC radio) then the same MMSI number must be used to program your product.

Note:

If a MMSI number is not entered, the DSC functionality of your radio will be disabled.

In the United States of America, the MMSI and Static Data must be entered only by a Raymarine® dealer or other appropriately qualified installer of marine communications equipment on board vessels.

The user is NOT authorized to do this.

In some areas, a radio operator licence is required before a MMSI number will be issued. You can request a MMSI number from same agency that issues radio or Ship Radio licences in your area.

In Europe and other parts of the world outside of the United States of America, the MMSI and Static data can be set up by the user.

For further details, refer to the relevant Telecommunications Regulatory Body for your area.

Refer to [Appendix C MMSI Regulatory bodies and application submissions](#) for a list of contacts for obtaining MMSI numbers for some areas.



Warning: MMSI entry

You can only enter a MMSI number once, if you enter the number incorrectly or need to change your MMSI number, the unit will require re-programming by an authorized Raymarine dealer.

2.7 Automatic Transmitter Identification System (ATIS)

Your product includes ATIS functionality for use on the inland waterways of contracting governments of the *“Regional Arrangement on the Radiocommunication Service for Inland Waterways”* — also known as *“RAINWAT”*.

ATIS adds data at the end of radio transmissions that identifies your station. ATIS operation can be turned on or off as needed via the radio’s menu.

An ATIS ID can be obtained from the same agency that issues radio operator licenses in your area.

Your ATIS ID should be programmed into your product using the instructions provided.

Note:

Contracting RAINWAT countries include: Austria, Belgium, Bulgaria, Croatia, the Czech Republic, France, Germany, Hungary, Luxembourg, Moldova, Montenegro, the Netherlands, Poland, Romania, Serbia, the Slovak Republic and Switzerland.

Note:

When ATIS is enabled, certain programming steps have been implemented to protect the integrity of the RAINWAT agreement, including the blocking of DSC functions when ATIS is enabled.

2.8 Software updates

Raymarine periodically releases software updates for its products. These updates provide new features, current feature enhancements and bug fixes which improves product performance and usability.

The software update process requires a compatible MFD, powered by LightHouse™ 2 release 13.37 or above, or LightHouse™ 3 version LH3.2 or above.

- The MFD used to perform the software update must be the designated Data master and be connected / networked to the product being updated.
- If you are in any doubt as to the correct procedure for updating your product software, please refer to your local authorized dealer or Raymarine technical support for assistance.

Caution: Installing software updates

The software update process is carried out at your own risk. Before initiating the update process ensure you have backed up any important files.

Ensure that the unit has a reliable power supply and that the update process is not interrupted.

Damage caused by incomplete updates are not covered by Raymarine warranty.

By downloading the software update package, you agree to these terms.

Checking software versions

You can check the software version of your radio and connected components.

From the Homescreen:

1. Select **Menu > Set-up > Maintenance > About this unit.**
2. Scroll down.
Software versions of connected components are displayed.

Ray90/Ray91 software

The following Ray90/Ray91 components include software that can be updated:

- Base station
- Wired handsets
- Wireless hub
- Wireless handsets

Performing the software update process using a compatible MFD will update the software for all connected components.

Note:

- Prior to performing the software update process, ensure that all components are powered on and that any Wireless handsets are plugged into their charging holsters.
- Wired handsets that contain software versions below VH1.32 must be placed into software update mode and updated separately from the Base station.

Performing software updates — Raymic handset

If your wired handset is running software version V1.32 or above then the handset will be updated automatically at the same time as the Base station. If your handset is running a software version below V1.32 then your Base station and handset must be updated separately.

- The radio must be connected to a compatible MFD over SeaTalkng®.
- The Data master MFD must be used to perform software update.

- Once you have updated your Base station software follow the steps below to update your handset.
1. Ensure a memory card that contains the necessary software files is inserted into the card reader of your MFD.
 2. With the Radio's Base station powered on, turn off the Raymic Handset by pressing the **Power** button located on the top of the Handset.
 3. Press and hold the **Distress** and **PTT** buttons on the Handset.
 4. Press the Handset **Power** button for 1 second, until the backlight turns on, and then release all three buttons.
The Handset is now in update mode.
 5. Now check for software updates using your MFD:
 - LightHouse™ 2 — From the Homescreen select: **Set-up > Maintenance > Check Card for Updates**.
 - LightHouse™ 3 — From the Homescreen select: **Settings > Updated software > Check SD card**.
 6. Select your Radio and select **Update**.
(The LCD backlight will flash when the update is in progress.)
 7. When the update is complete, check your radios software version.
 8. Removed the memory card from the card reader.

Chapter 3: Installation

Chapter contents

- [3.1 Selecting a location on page 34](#)
- [3.2 GNSS \(GPS\) location requirements on page 36](#)
- [3.3 Wireless product location requirements on page 37](#)
- [3.4 Product dimensions on page 39](#)
- [3.5 Mounting on page 44](#)

3.1 Selecting a location



Warning: Potential ignition source

This product is NOT approved for use in hazardous/flammable atmospheres. Do NOT install in a hazardous/flammable atmosphere (such as in an engine room or near fuel tanks).

General location requirements

When selecting a location for the unit it is important to consider a number of factors.

Ventilation requirements

To provide adequate airflow:

- Ensure that equipment is mounted in a compartment of suitable size.
- Ensure that ventilation holes are not obstructed.
- Ensure adequate separation of equipment.

Mounting surface requirements

When selecting a mounting surface ensure:

- the product will be adequately supported on a secure, flat surface. Do NOT mount units or cut holes in places which may damage the structure of the vessel.
- sufficient space is available around the product.
- there is nothing behind the mounting surface that may be damaged when drilling.

Cable routing requirements

Ensure you have identified the route that all required cables will take and that sufficient space is available to allow connection of cables:

- Unless otherwise stated, a minimum cable bend radius of 100 mm (3.94 in) is required.
- Where necessary, cable supports should be used to prevent stress on connectors.

Electrical interference

Select a location that is far enough away from devices that may cause interference, such as motors, generators and radio transmitters/receivers.

Power supply

Select a location that is as close as possible to the vessel's DC power supply. This will help to keep cable runs to a minimum.

RF interference

Certain third-party external electrical equipment can cause Radio Frequency (RF) interference with GNSS (GPS), AIS or VHF devices, if the external equipment is not adequately insulated and emits excessive levels of electromagnetic interference (EMI).

Some common examples of such external equipment include LED spot or strip lights, and terrestrial TV tuners.

To minimize interference from such equipment:

- Keep it as far away from GNSS (GPS), AIS or VHF devices as possible.
- Ensure that any power cables for external equipment are not entangled with the power or data cables for these devices.
- Consider fitting one or more high frequency suppression ferrites to the EMI-emitting device. The ferrite(s) should be rated to be effective in the range 100 MHz to 2.5 GHz, and should be fitted to the power cable and any other cables exiting the EMI-emitting device, as close as possible to the position where the cable exits the device.

Compass safe distance

When choosing a suitable location for your product you should aim to maintain the maximum possible distance between the product and any installed compass. This distance should be at least 1 m (3 ft) in all directions. For smaller vessels it may not be possible to achieve this distance. In this situation ensure that the compass is not affected by the product when it is powered on.

EMC installation guidelines

Raymarine® equipment and accessories conform to the appropriate Electromagnetic Compatibility (EMC) regulations, to minimize electromagnetic interference between equipment and minimize the effect such interference could have on the performance of your system

Correct installation is required to ensure that EMC performance is not compromised.

Note:

In areas of extreme EMC interference, some slight interference may be noticed. Where this occurs the product and the source of the interference should be separated by a greater distance.

For **optimum** EMC performance we recommend that wherever possible:

- Raymarine® equipment and cables connected to it are:
 - At least 1 m (3 ft) from any equipment transmitting or cables carrying radio signals e.g. VHF radios, cables and antennas. In the case of SSB radios, the distance should be increased to 2 m (7 ft).
 - More than 2 m (7 ft) from the path of a Radar beam. A Radar beam can normally be assumed to spread 20 degrees above and below the radiating element.
- The product is supplied power from a separate battery from that used for engine start. This is important to prevent erratic behavior and data loss which can occur if the engine start does not have a separate battery.
- Only Raymarine® specified cables are used.
- Cables are not cut or extended, unless doing so is detailed in the installation instructions.

Note:

Where constraints on the installation prevent any of the above recommendations, always ensure the maximum possible separation between different items of electrical equipment, to provide the best conditions for EMC performance throughout the installation.

Suppression ferrites

- Raymarine cables may be pre-fitted or supplied with suppression ferrites. These are important for correct EMC performance. If ferrites are supplied separately to the cables (i.e. not pre-fitted), you must fit the supplied ferrites, using the supplied instructions.
- If a ferrite has to be removed for any purpose (e.g. installation or maintenance), it must be replaced in the original position before the product is used.
- Use only ferrites of the correct type, supplied by Raymarine or its authorized dealers.
- Where an installation requires multiple ferrites to be added to a cable, additional cable clips should be used to prevent stress on the connectors due to the extra weight of the cable.

Connections to other equipment

Requirement for ferrites on non-Raymarine cables.

If your product is to be connected to other equipment using a cable not supplied by Raymarine, a suppression ferrite **MUST** always be attached to the end of the cable nearest to the Raymarine product.

Antenna mounting and EME exposure

Ensure that your VHF antenna is connected to the radio before transmission.

Raymarine® declares a Maximum Permissible Exposure (MPE) radius of 1.8 meters (5.9 ft.) for this system, assuming 25 watts output to an omnidirectional antenna of 3dBi gain or less.

For watercraft with suitable structures, the antenna base must be at least 3.8 meters (12.5 ft) above the main deck to meet the MPE for persons up to 2 metres (6.6 ft) tall. For watercraft without such structures, the antenna must be mounted so that its base is a minimum of 1.8 meters (5.9 ft.) vertically from heads of all persons.

The antenna must be isolated from the vessel's metalwork using an insulated (e.g. plastic) mounting bracket.

3.2 GNSS (GPS) location requirements

Your product includes a built-in GNSS (GPS) receiver that, in order to obtain a position fix, requires connection of an external passive antenna, such as the GA150 antenna.

Ensure you follow the location requirements specified in your external antenna's installation instructions.

3.3 Wireless product location requirements

The optional wireless hub, handset and active speakers require further considerations when selecting a mounting location

Wireless location requirements

A number of factors can influence wireless performance, it is important to ensure you test the connection performance, at the desired location before installing wireless enabled products.

Distance

The distance between wireless products should always be kept to a minimum. Do not exceed the maximum stated range of your wireless product (Maximum range will vary for each device).

Wireless performance degrades over distance, so products farther away will receive less network bandwidth. Products installed close to their maximum wireless range may experience slow connection speeds, signal drop outs or not being able to connect at all.

Line of sight

For best results the wireless product should have a clear, direct line of sight to the product it will be connected to. Any physical obstructions can degrade or even block the wireless signal.

The construction of your vessel can also have an impact on wireless performance. For example, metal structural bulkheads and roofing will reduce and in certain situations, block the wireless signal.

If the wireless signal passes through a bulkhead containing power cables this can also degrade wireless performance.

Reflective surfaces such as metal surfaces, some types of glass and even mirrors can drastically effect performance or even block the wireless signal.

Interference and other equipment

Wireless products should be installed at least 1m (3 ft) away from:

- Other wireless enabled products.
- Transmitting products that send wireless signals in the same frequency range.
- Other electrical, electronic or electromagnetic equipment that may generate interference.

Interference from other peoples wireless devices can also cause interference with your products. You can use a third party wireless analyzer tool / smartphone app to assess the best wireless channel (channel not in use or used by least amount of devices) for you to use.

Pre-installation site survey

Before installing a wireless device, a site survey should be performed to ensure the wireless signal strength at the desired installation location is sufficient to maintain a reliable connection.

You can perform a site survey using your smart phone or tablet and a wireless signal analyzer app such as “Wi-Fi Analyzer” by Farproc or a similar.

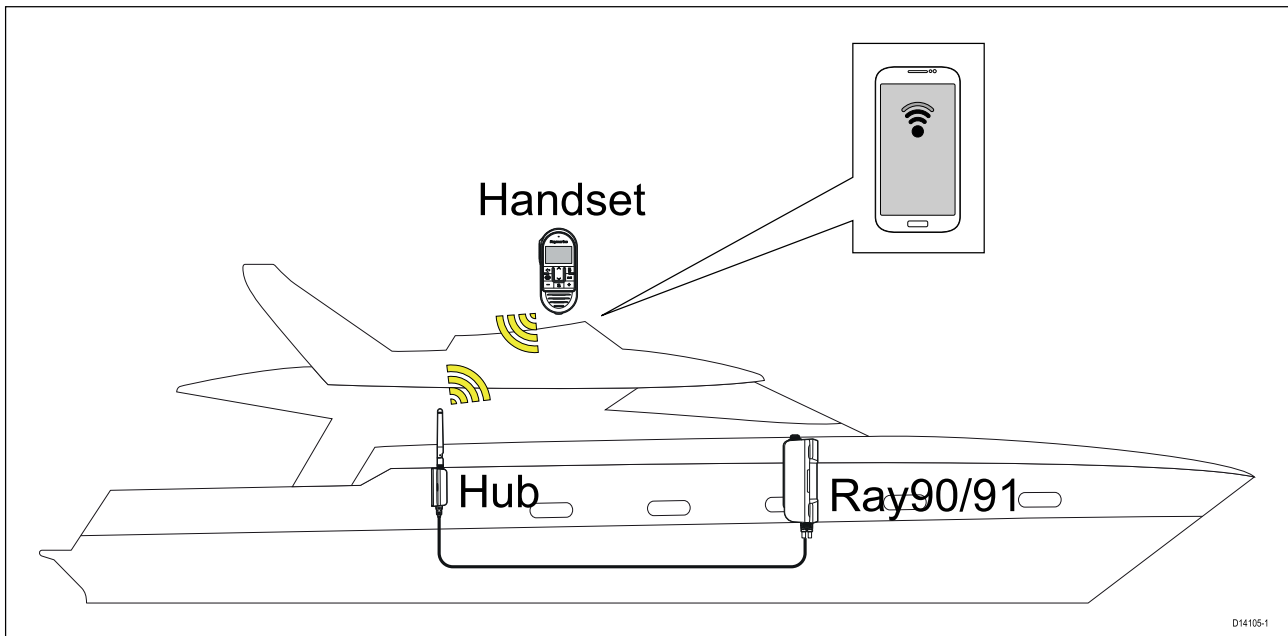

1. Install the wireless analyzer app on your smart device.
2. Connect the Wireless hub to the Ray90 base station.
3. Move the hub to its desired location.

The hub should be located as close to the desired location of the Wireless handset as possible, this can be achieved using the fitted 5 metre cable and if required the Wireless hub antenna extension, which allows a farther 5 metres.

4. Power on your Ray90 base station.
5. Make a note of your Wireless hub's name.

*The Wireless hub's name can be found using a Wired handset: **Menu > Set-up > Wireless set-up > Wireless hub set-up > Hub name**. (By default the hub name will be "RayHub").*

6. Go to the location you have chosen for your Wireless handset.
7. Open the wireless analyzer app on your smart device and scan available networks.
8. Establish the signal strength of your Hub's wireless network at the chosen location.

For reliable wireless performance the signal strength should be better than -75dBm , the closer the signal is to zero the better the wireless performance will be (e.g. -40dBm is better than -75dBm).

9. If the wireless channel your Hub is using is congested with wireless signals then change your Hub's wireless channel (**Menu > Set-up > Wireless set-up > Wireless hub set-up > Hub name** select a different Wireless channel

Try channels 1, 6 and 11 first as these are usually the preferred wireless channels. Otherwise try the channel that has the least congestion.

10. If you have a very weak or intermittent signal then you will need to investigate further, please refer to the Wireless location requirements to help establish what may be causing the problem.
11. Repeat steps 6 to 10 with each Wireless handset you wish to install.

3.4 Product dimensions

Product dimensions - Base station

The Base station dimensions are listed below.

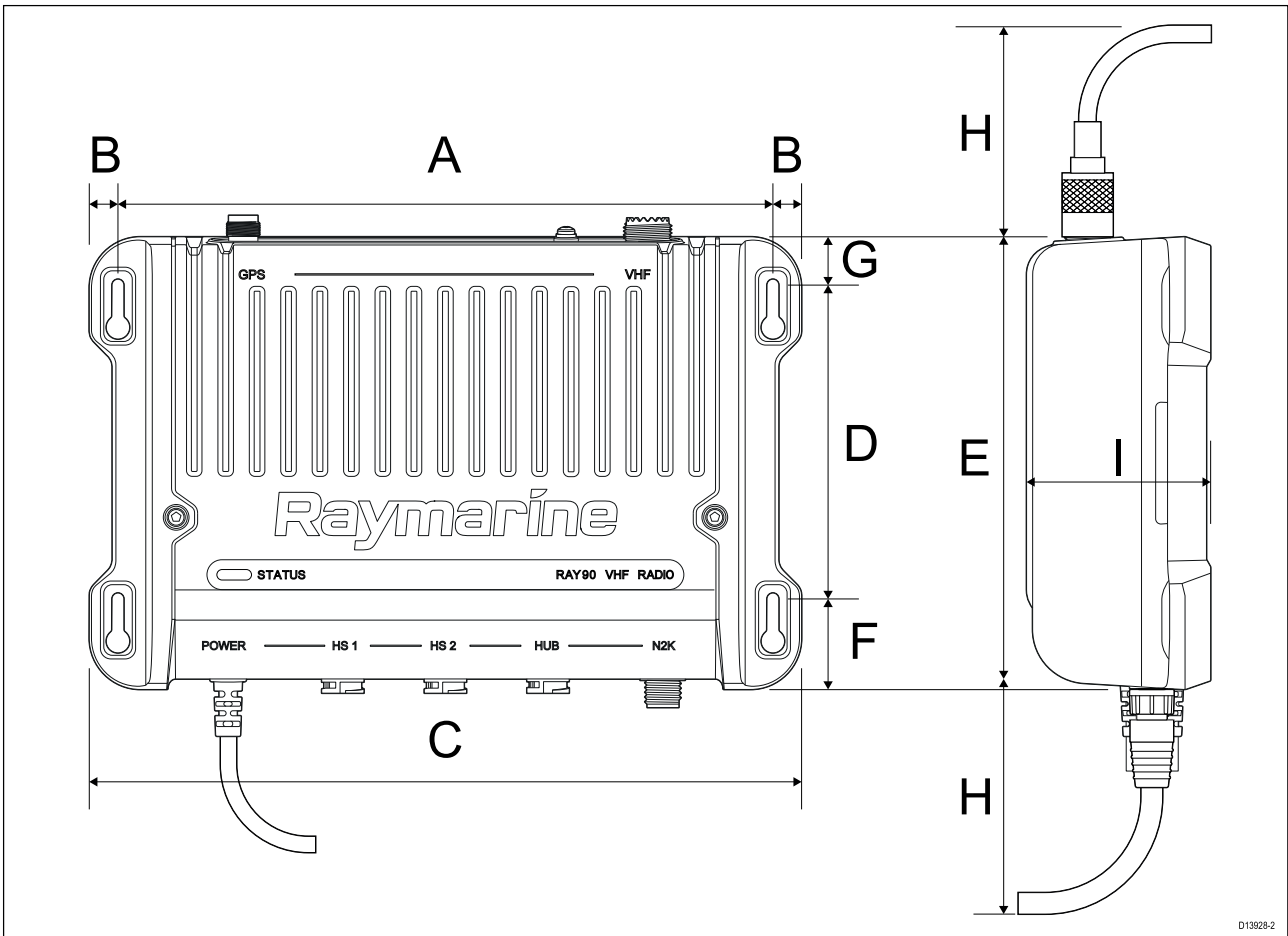

A	217 mm (8.54 in)
B	9.5 mm (0.37 in)
C	235.95 mm (9.29 in)
D	104 mm (4.09 in)
E	149.95 mm (5.91 in)
F	30 mm (1.18 in)
G	14 mm (0.55 in)
H	90 mm (3.54 in)
I	61 mm (2.40 in)

The Base station includes a fitted power cable and data cable, The power cable length is 1.2 m (3.94 ft) and the Data cable length is 420 mm (1.38 ft).

Product dimensions - speakers

The dimensions for the Passive and Active speakers are shown below.

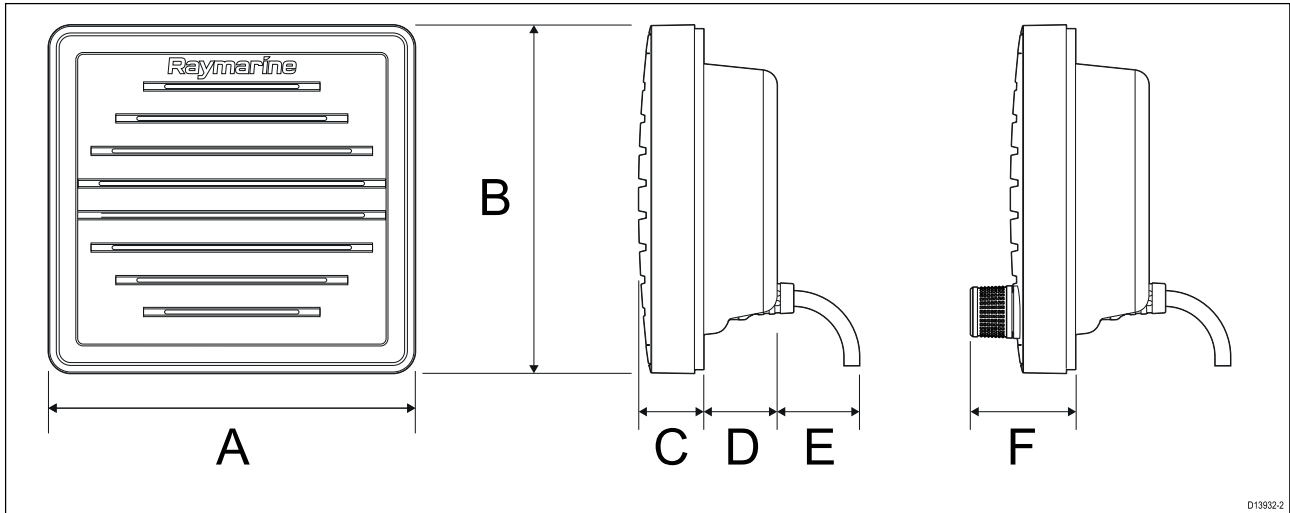

013932-2

A	118.5 mm (4.67 in)
B	112.5 mm (4.43 in)
C	18.3 mm (0.72 in)
D	26.4 mm (1.04 in)
E	25 mm (0.98 in)
F	30.6 mm (1.20 in)

The Passive speaker includes a fitted 2 m (6.56 ft) audio cable terminated with a male RCA plug.

The Active speaker includes a fitted 2 m (6.56 ft) power cable terminated with a spade connectors.

Product dimensions - Wired handset (Raymic)

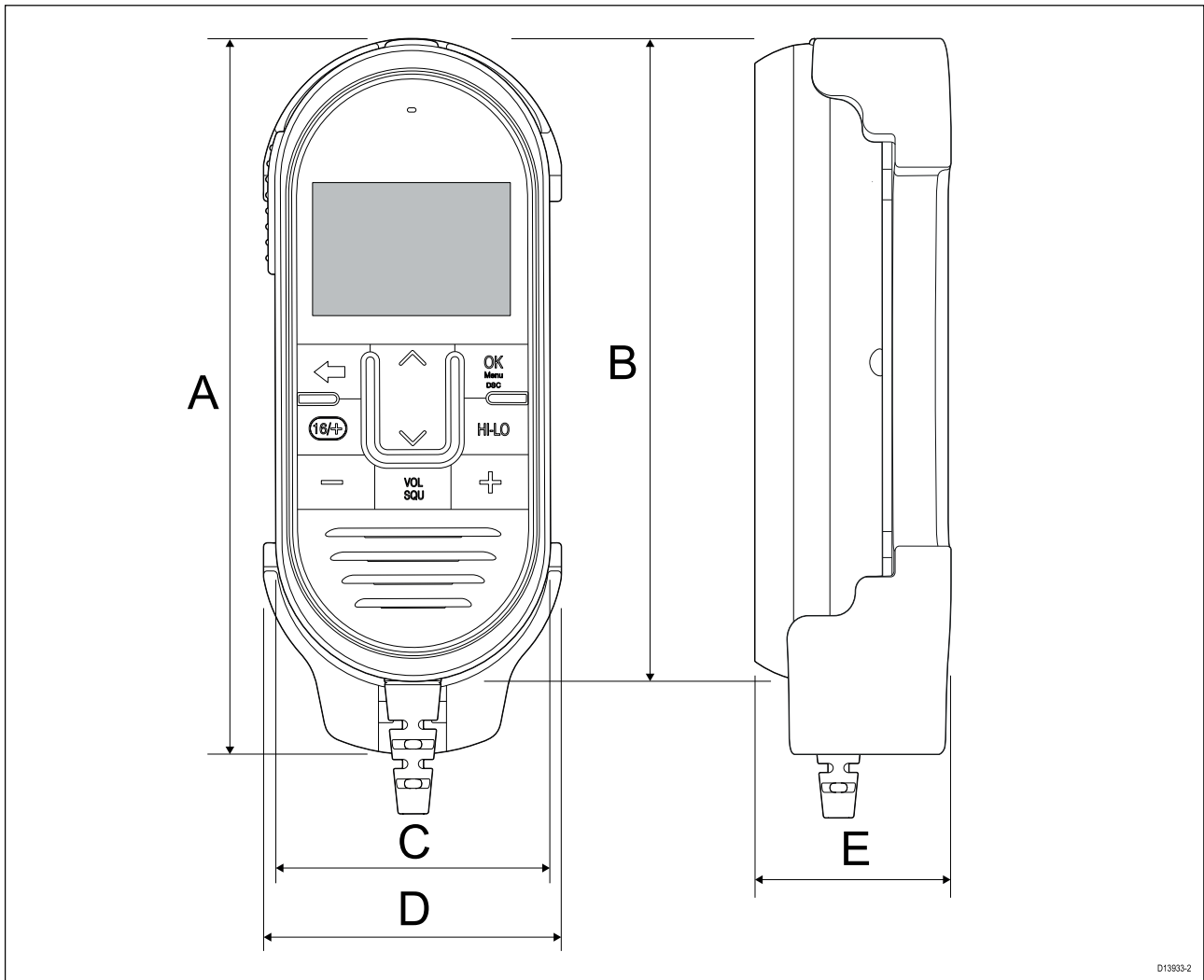

D13833-2

A	167.34 mm (6.59 in)
B	151 mm (5.94 in)
C	66.9 mm (2.63 in)
D	70 mm (2.76 in)
E	46.7 mm (1.84 in)

The Handset's fitted, coiled lead can be extended comfortably to approximately 1 meter (3.3 ft.). Ensure sufficient space is available below the desired mounting area to accommodate the cable.

Product dimensions - Wireless hub

The dimensions for the wireless hub are shown below.

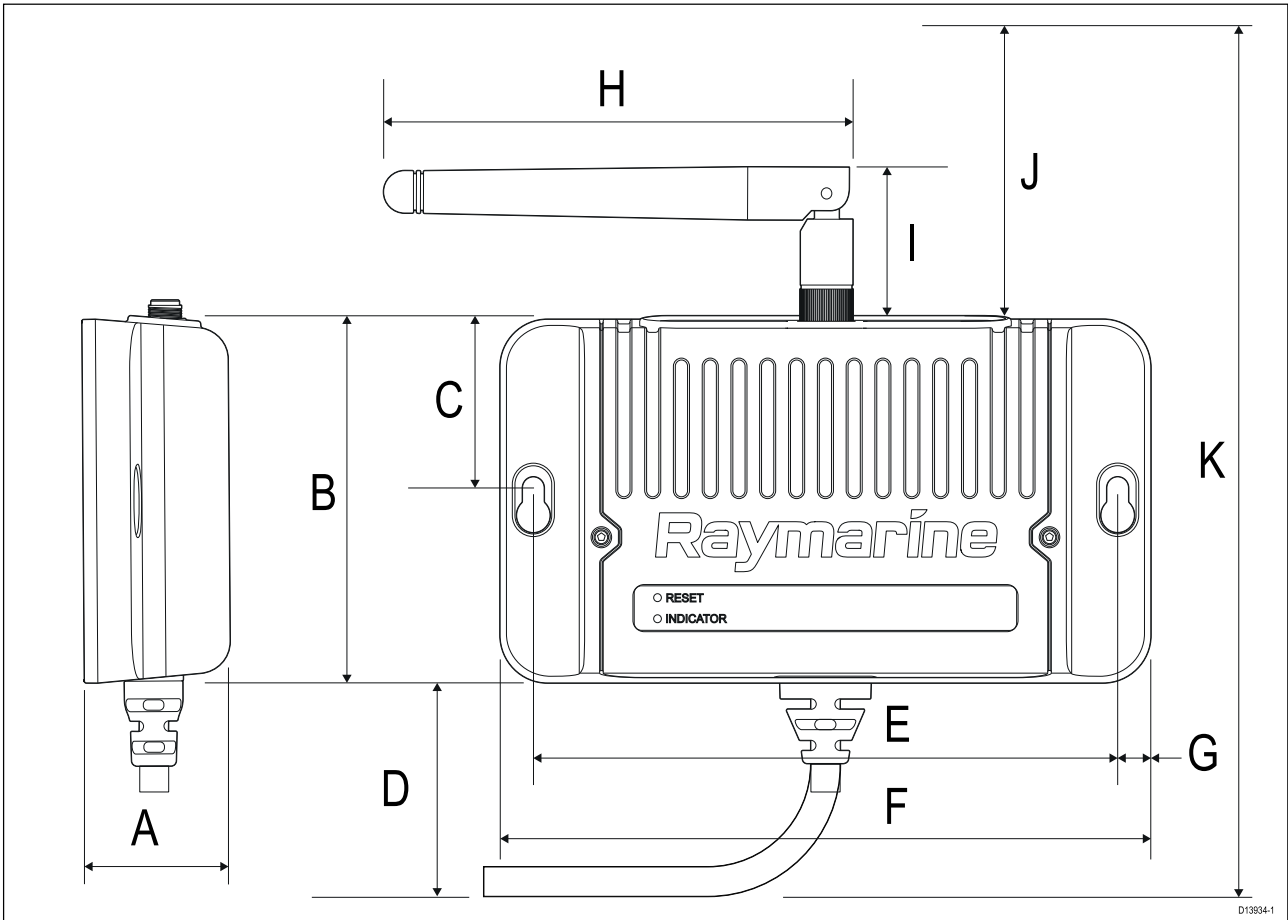

A	26.7 mm (1.05 in)
B	68.04 mm (2.68 in)
C	32.16 mm (1.27 in)
D	70 mm (2.76 in)
E	109.2 mm (4.30 in)
F	121.6 mm (4.79 in)
G	6.2 mm (0.24 in)
H	87.72 mm (3.45 in)
I	29.14 mm (1.15 in) Min
J	106.95 mm (4.21 in) Max
K	244.99 mm (9.65 in)

The Wireless hub includes a fitted 5 m (16.4 ft) cable for connection to the Ray90 / Ray91 Base station. If the installation requires the cable to be passed through a bulkhead or panelling a 20 mm (0.79 in) diameter hole is required to allow the connector to pass through.

Product dimensions - Wireless handset and holster

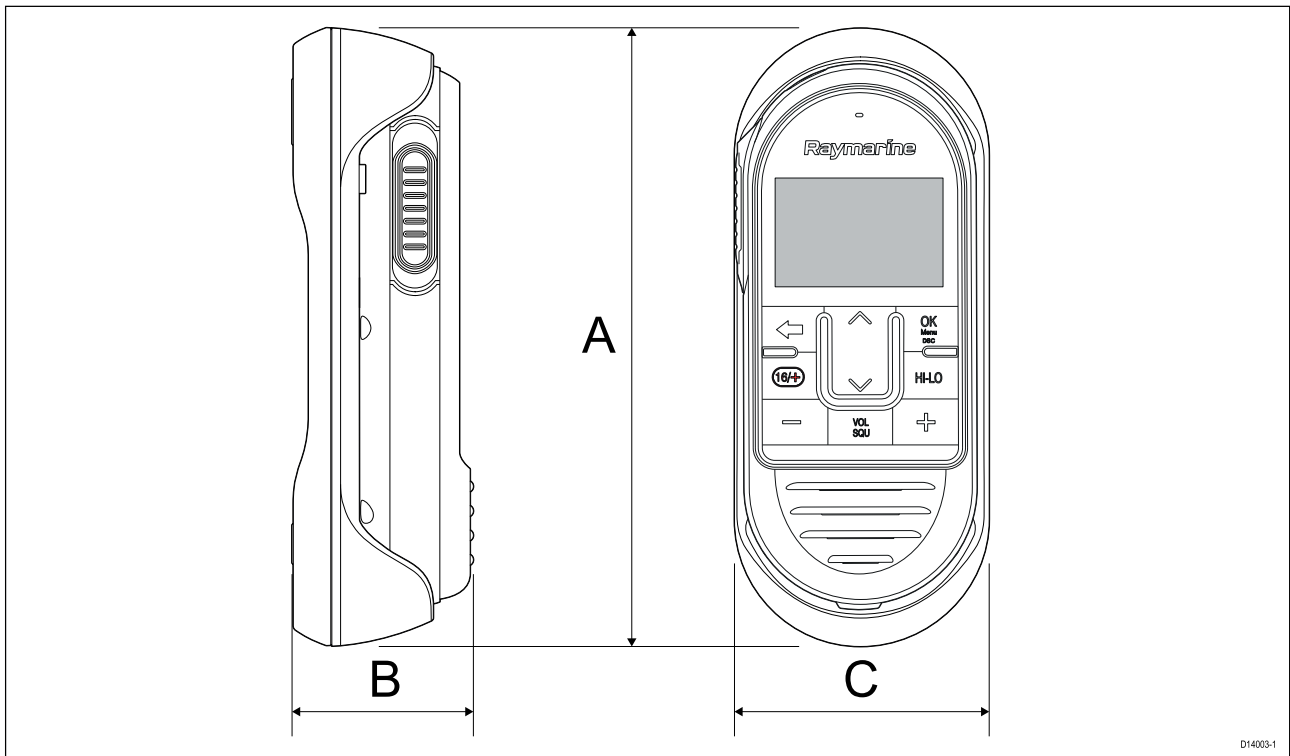

D14003-1

A	173.33 mm (6.82 in)
B	50.5 mm (1.99 in)
C	71.41 mm (2.81 in)

The charging holster is supplied with a fitted 2 meter (6.56 ft) power cable terminated with bare ended wires.

3.5 Mounting

Tools required for installation

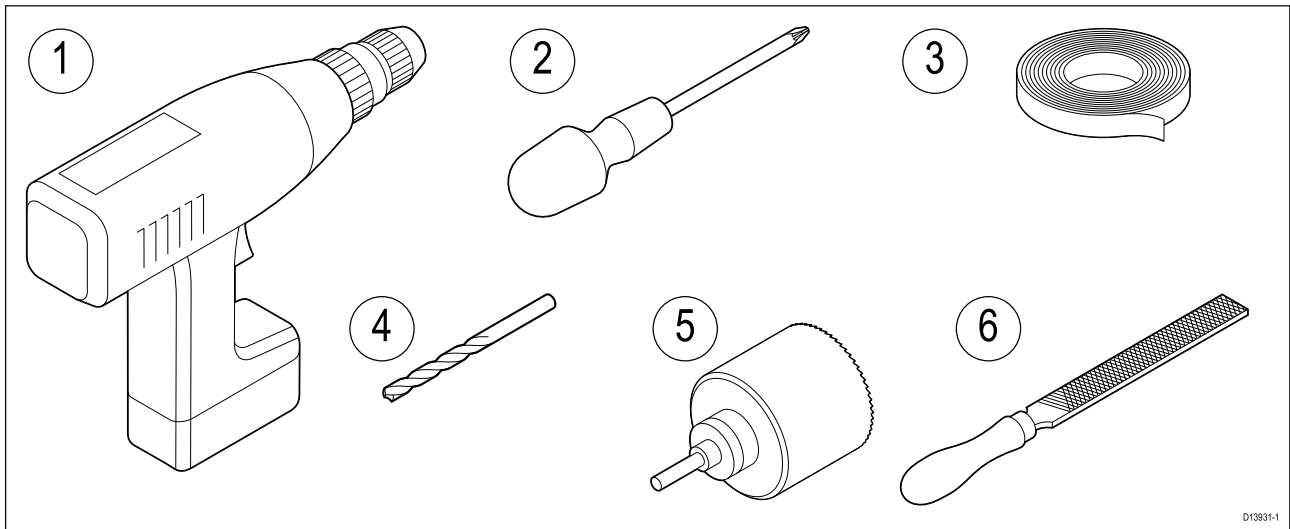

1. Power drill
2. Pozi-drive screwdriver
3. Adhesive tape
4. Suitable size drill bit
5. 89 mm (3 ½ in) Hole saw (used for speaker mounting)
6. File (for speaker cut-out)

Mounting the Base station

Before mounting, ensure that your selected location meets the location requirements found in this document.

- Also ensure you have planned the location for any additional components, such as the Handset or Speaker etc.

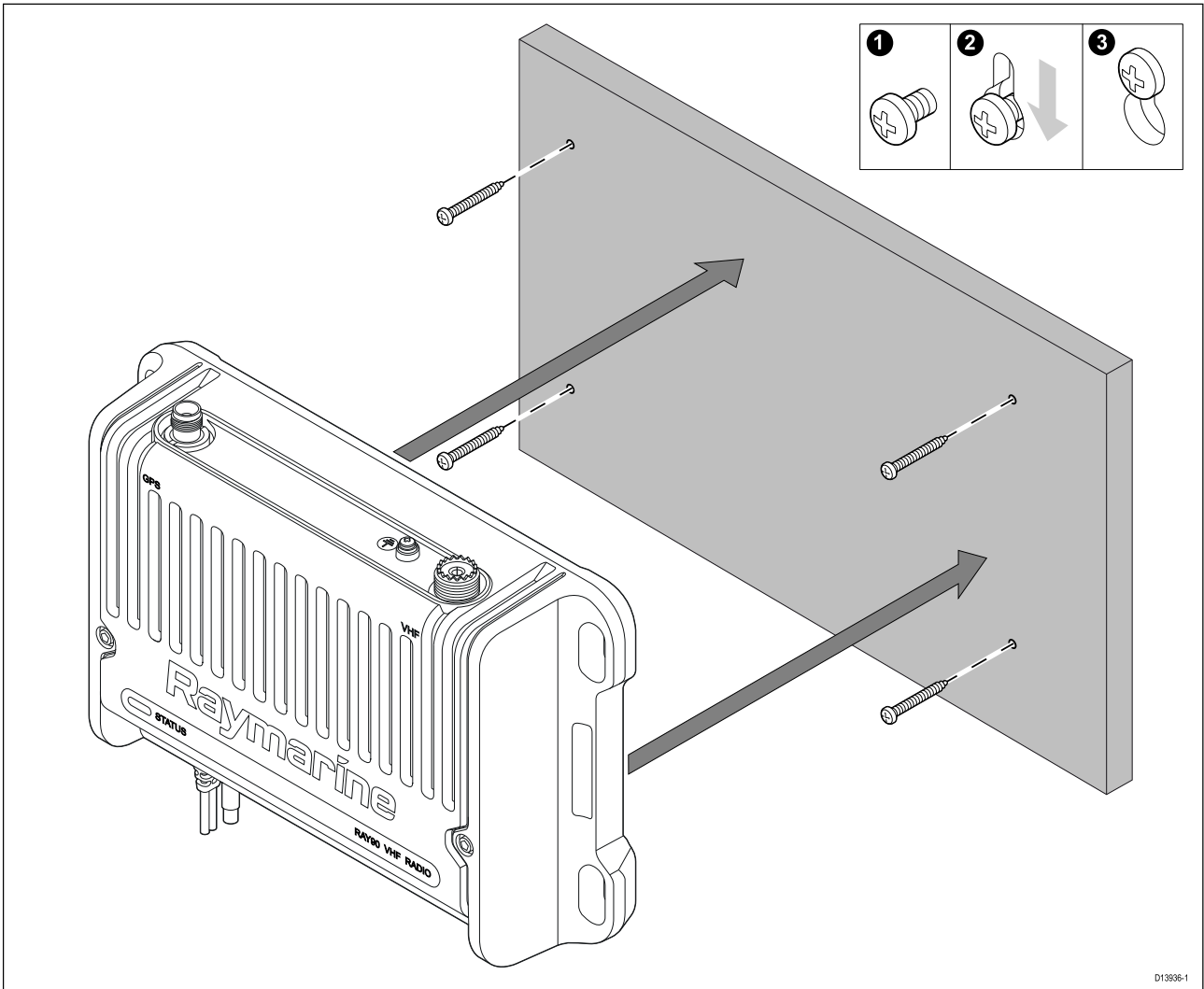

1. Using the supplied mounting template, mark the location of the fixing holes on the mounting surface.
2. Drill holes for the mounting fixings using a drill with a suitable sized drill bit.
3. Screw the fixings approximately half way into the holes in the mounting surface.
4. Place the Base station over the fixings screws and push down to lock into position.
5. Fully tighten the screws.
6. Connect the necessary cables.

Wired and wireless speaker mounting

Before mounting, ensure that your selected location meets the location requirements found in this document.

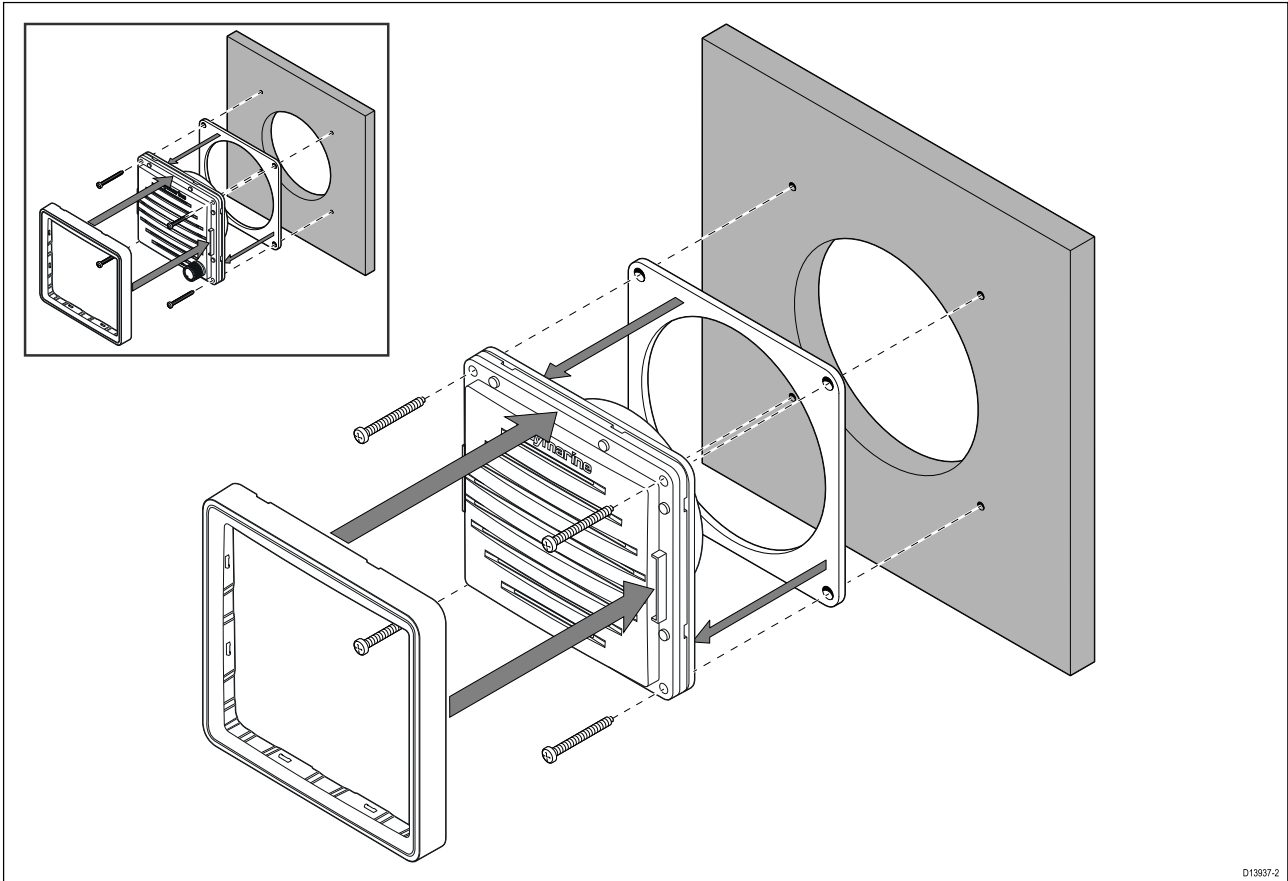

D13937-2

1. Remove the speaker's bezel.
2. Using the supplied mounting template, mark the location of the cut out and fixing holes on the mounting surface.
3. Using a 89 mm (3 ½ in) hole saw, drill out the centre cut out area indicated on the mounting template.
4. Drill holes for the fixings, using a drill with a suitable sized bit.
5. Ensure that the unit fits into the removed area and then file around the cut edge until smooth.
6. Peel the backing off of the supplied gasket and place the adhesive side of the gasket onto the rear of the speaker, pressing firmly onto the flange.
7. Connect the relevant cable to the speaker.
8. Slide the speaker into place and secure using the fixings provided.
9. Fit the Bezel, ensuring it clips into place on all 4 sides.

Handset (wired) mounting using the holster

Follow the steps below to mount the Wired handset (also known as thew Raymic).

Before mounting, ensure that your selected location meets the location requirements found in this document.

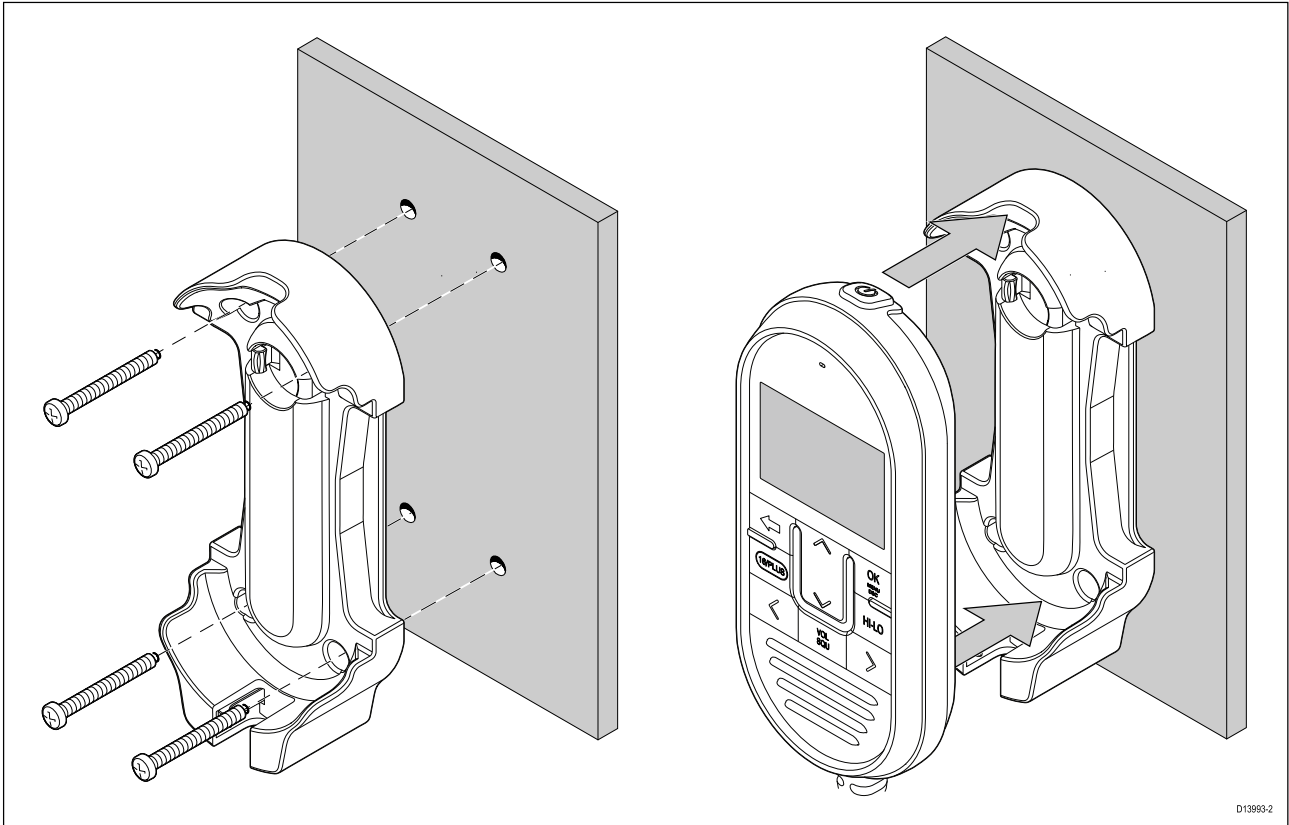

1. Check the selected location for the mounting holster, a clear flat area is required, with sufficient space around it to place and remove the Handset.
2. Using a pencil, offer up the holster to the desired location and mark the location of the screw holes on the mounting surface.
3. Drill the mounting holes using a suitable size drill bit.
4. Hold the holster in place and secure using the screws provided.
5. Place the Handset into the holster until it clicks into position.

Pass-through panel kit mounting

When installing handsets, the pass-through panel kit should be used to secure the cable's connector to the panel the cable has to pass through.

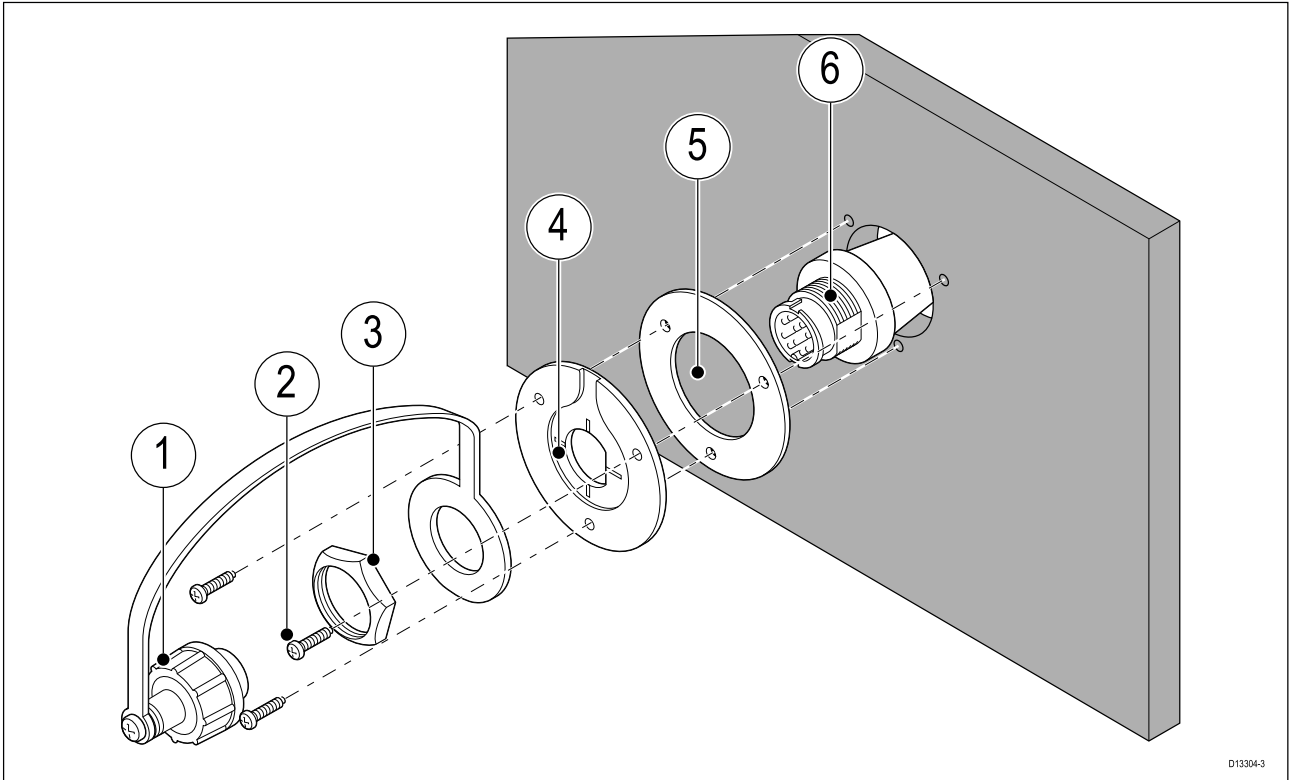

D13304-3

1	Splash-proof dust cap with lanyard
2	Mounting plate fixings x 3
3	Mounting plate nut
4	Mounting plate
5	Mounting plate gasket
6	Extension cable

1. Check the selected location for the Mounting plate, a clear flat area is required.
2. Ensuring correct orientation of the mounting plate, offer up the plate to the desired location and mark the location of the screw holes and the center hole on the mounting panel.

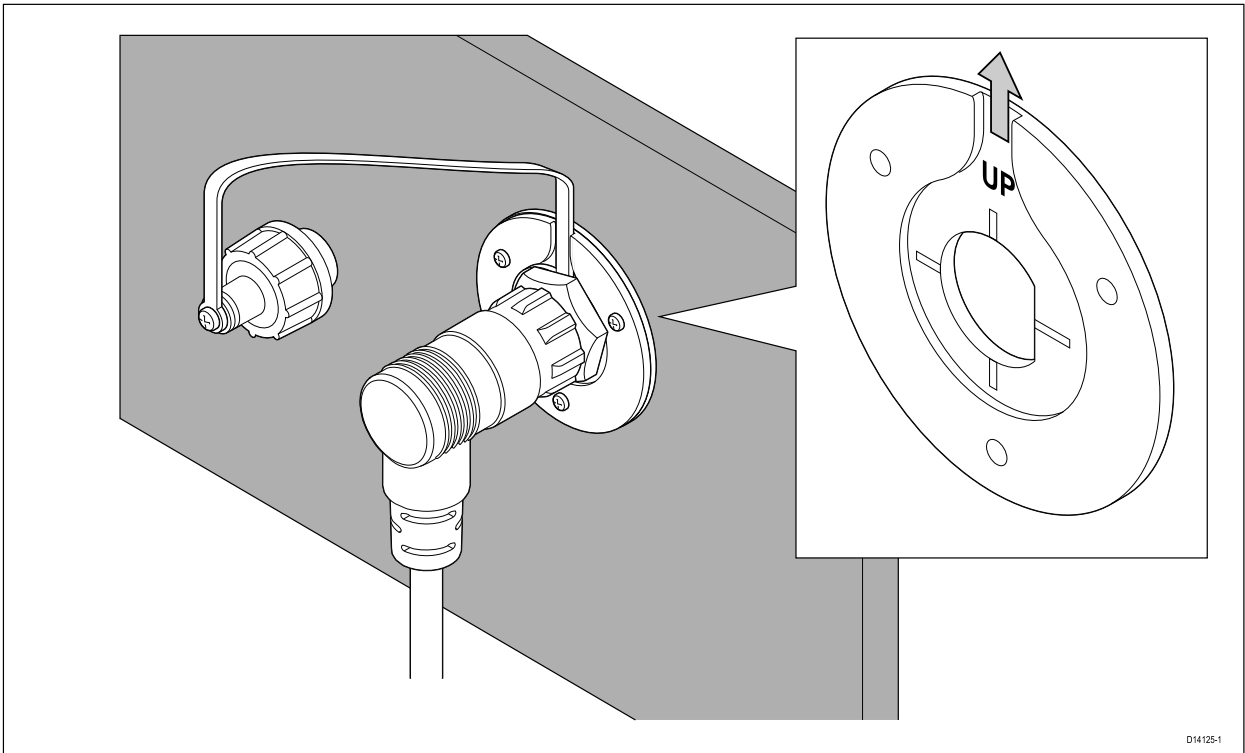

D14125-1

To ensure that the handset's connector points down when connected, orientate the mounting plate so that the lanyard groove is pointing straight up.

3. Drill the mounting holes using a suitable size drill bit.
4. Drill the center hole using a 25 mm (1 in.) hole cutting saw.
5. Pull the connector end of the cable through the hole in the mounting surface.
6. Place the Mounting plate gasket over the end of the connector.
7. With the recessed side facing away from the mounting panel, place the Mounting plate over the end of the connector.
8. Place the lanyard end of the Splash-proof dust cap over the connector, ensuring the lanyard sits in the recess in the Mounting plate.
9. Place the Mounting plate nut over the connector and tighten clockwise using a 13/16 in. (21 mm) socket wrench, being careful not to damage the plastic nut by overtightening.
10. Secure the Mounting plate to the mounting surface using the supplied screws.
11. Attach the Handset / Fismic connector to the cable connector and rotate the locking collar clockwise to secure.
12. Connect the opposite end of the cable to the required connector either on the Base station or to another pass-through panel mounting plate connector.

Note:

Drill bit, tap size and tightening torque is dependent on the thickness and type of material the unit is to be mounted on.

Mounting the wireless hub

Before mounting, ensure that:

- your selected location meets the location requirements found in this document.
- you pay particular attention to the wireless location requirements.
- sufficient space is available above or to one side of the hub for the antenna.
- the product operates correctly at the desired location before mounting.

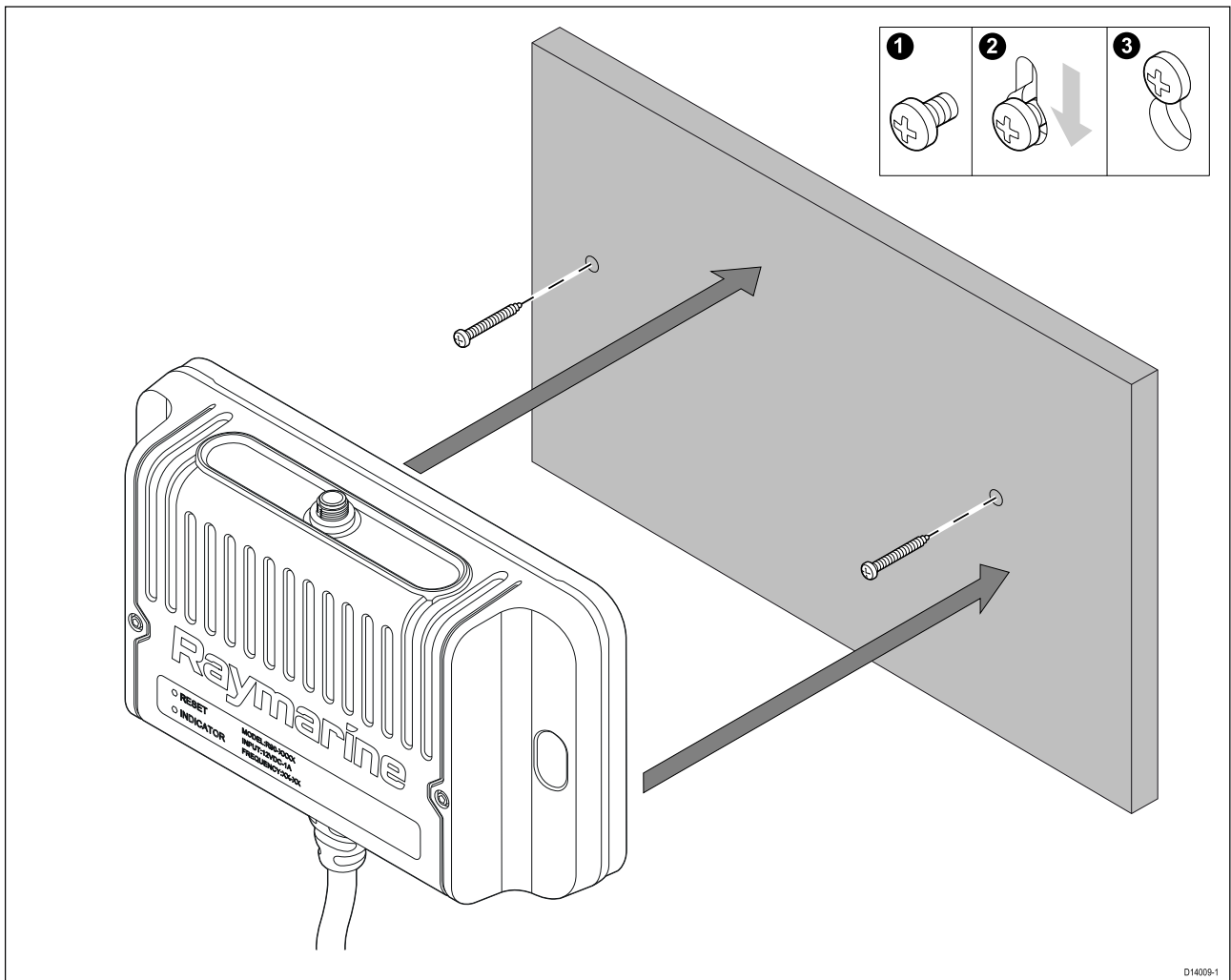

1. Using the supplied mounting template, mark the location of the fixing holes on the mounting surface.
2. Drill holes for the mounting fixings using a drill with a suitable sized drill bit.
3. Screw the fixings approximately half way into the holes in the mounting surface.
4. Place the Wireless hub over the fixing screws and push down to lock into positions
5. Fully tighten the screws.
6. Connect the antenna to the top of the hub.

Antenna orientation

Radio waves are emitted from the wireless hub perpendicular to the orientation of the hub's antenna.

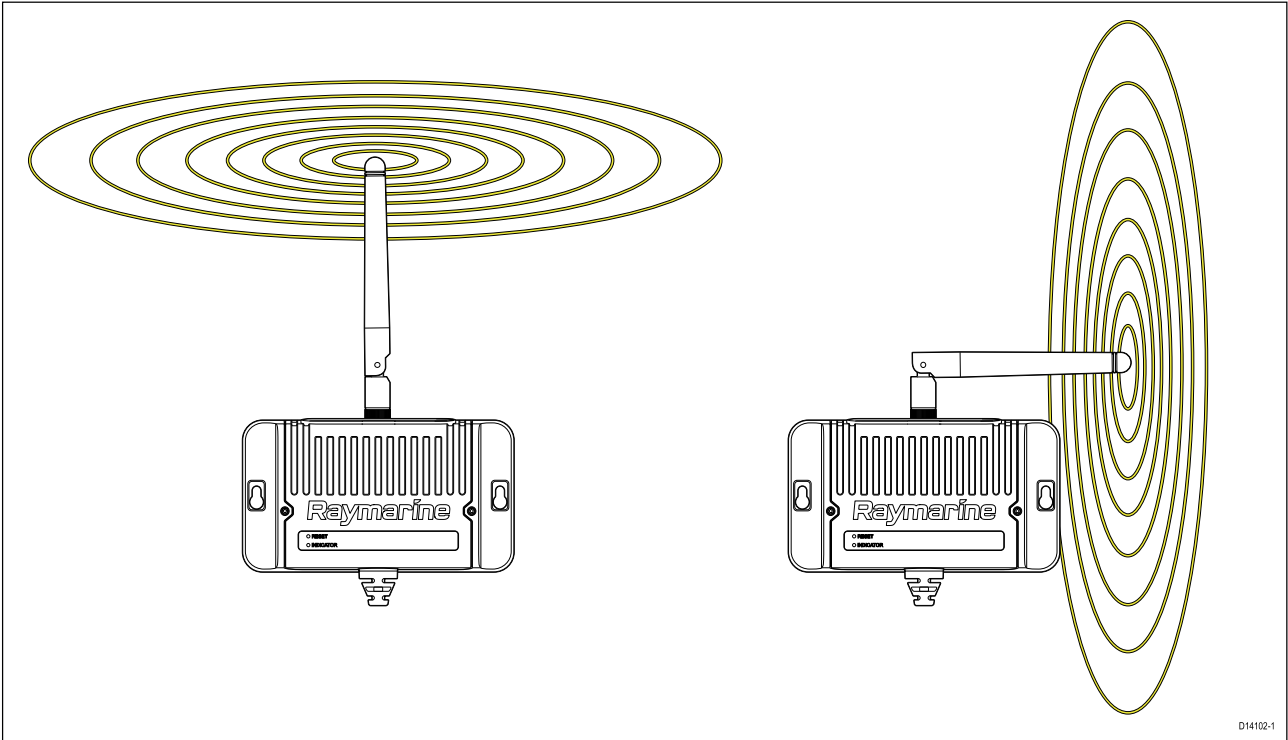

Keeping the antenna vertical should provide the best coverage for devices on the same plane as your hub. Positioning the antenna horizontally will provide better coverage above and below the hub.

Installing the wireless hub antenna extension accessory

An extension cable accessory (A80541) is available for the wireless hub's antenna. Using the extension the distance of the wireless hub's antenna can be extended a farther 5 m (16.4 ft).

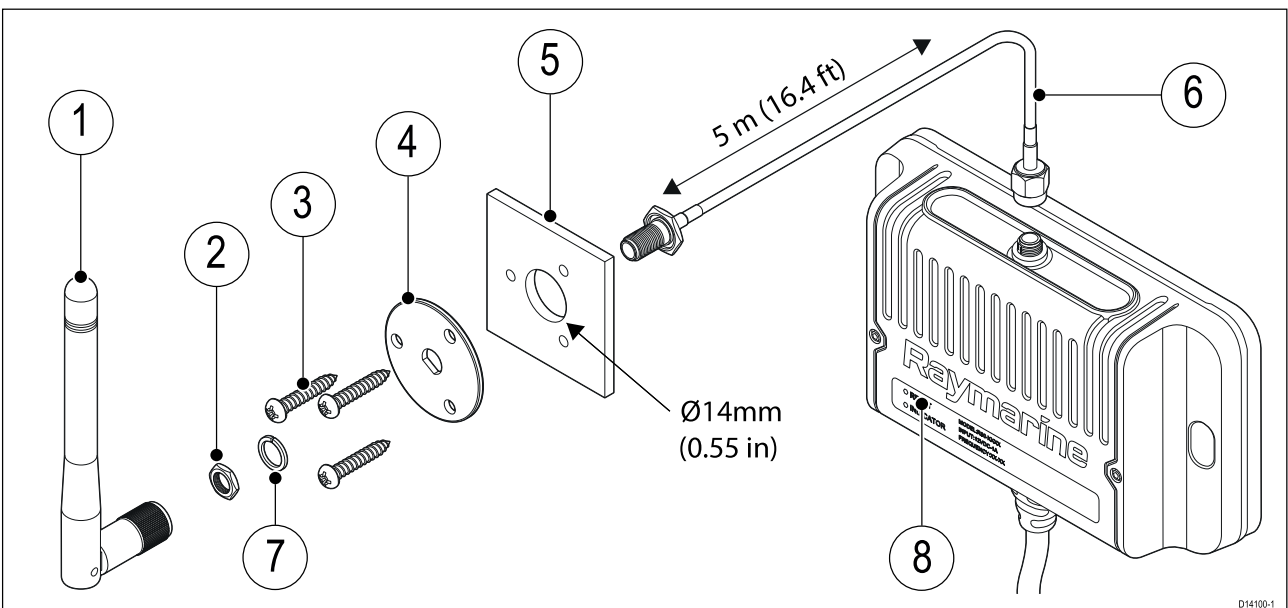

1	Antenna (supplied with the hub)	2	Nut
3	M3x10 fixing screws x 3	4	Mounting plate
5	Mounting surface (14 mm (0.55 in) diameter hole required)	6	5 m (16.4 ft) antenna extension cable
7	Split washer	8	Wireless hub

1. Check the selected location for the Mounting plate, a clear flat area is required.
2. Using a pencil, offer up the Mounting plate to the desired location and mark the location of the screw holes and the center hole on the mounting panel.
3. Drill holes for the mounting fixings using a drill with a suitable sized drill bit.
4. Drill the center hole using a 14 mm (0.55 in) drill/hole cutter.
5. Pull the connector end with the exposed thread through the center hole.
6. Place the mounting plate over the end of the connector.
7. Place the split washer and nut over the end of the connector and secure by hand tightening the nut.
8. Secure the mounting plate to the mounting surface using the supplied screws.
9. Screw the antenna supplied with your hub to the connector.
10. Connect the opposite end of the extension cable to the antenna connector located on the top of the wireless hub.

Mounting the charging holster for the wireless handset

Before mounting, ensure that:

- Your selected location meets the location requirements found in this document.
- You pay particular attention to the wireless location requirements.
- The product operates correctly at the desired location before mounting.
- The product does not interfere with nearby devices.

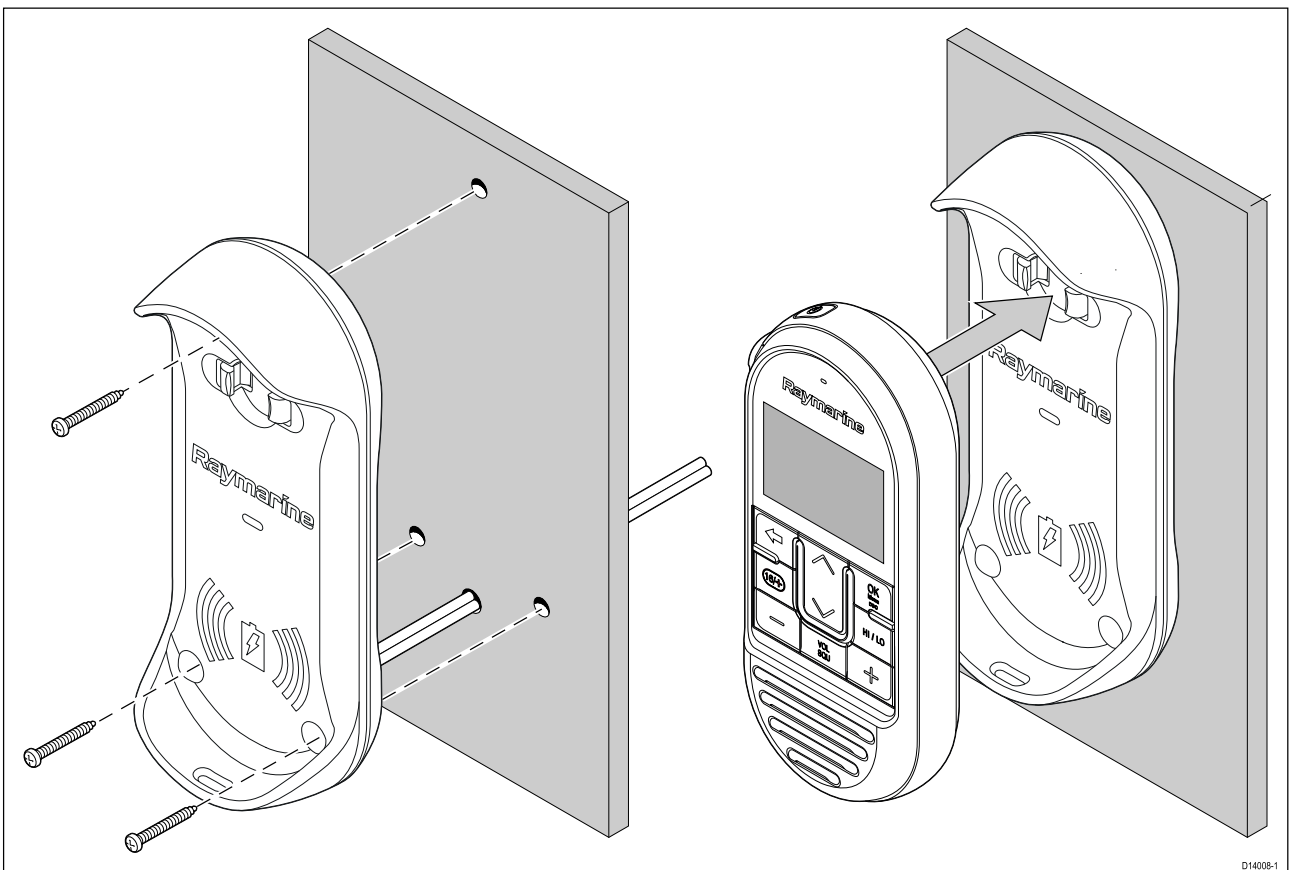

1. Using the supplied mounting template mark the location of the mounting holes and if required, the cable hole.

2. Drill the mounting holes using a suitable size drill bit.
3. If required, use a 6.5 mm (0.26 in) drill bit to drill a hole for the holster's power cable.
4. Hold the holster in place and secure using the screws provided.
5. Place the Handset into the holster, ensuring it clicks into position.

Chapter 4: Cables and connections

Chapter contents

- 4.1 General cabling guidance on page 54
- 4.2 Connections overview on page 56
- 4.3 Power connection on page 57
- 4.4 Handset station connection on page 62
- 4.5 Wired speaker connection on page 63
- 4.6 NMEA 2000 / SeaTalkng[®] connection on page 64
- 4.7 NMEA 0183 connection on page 66
- 4.8 Loud hailer connection on page 67
- 4.9 Connecting GNSS (GPS) and VHF antennas on page 68
- 4.10 Wireless hub connection on page 70
- 4.11 Wireless handset charging holster – power connection on page 71
- 4.12 Wireless handset connections on page 72
- 4.13 Wireless speaker – power connection on page 73

4.1 General cabling guidance

Cable types and length

It is important to use cables of the appropriate type and length

- Unless otherwise stated use only standard cables of the correct type, supplied by Raymarine.
- Ensure that any non-Raymarine cables are of the correct quality and gauge. For example, longer power cable runs may require larger wire gauges to minimize voltage drop along the run.

Routing cables

Cables must be routed correctly, to maximize performance and prolong cable life.

- Do NOT bend cables excessively. Wherever possible, ensure a minimum bend diameter of 200 mm (8 in) / minimum bend radius of 100 mm (4 in).

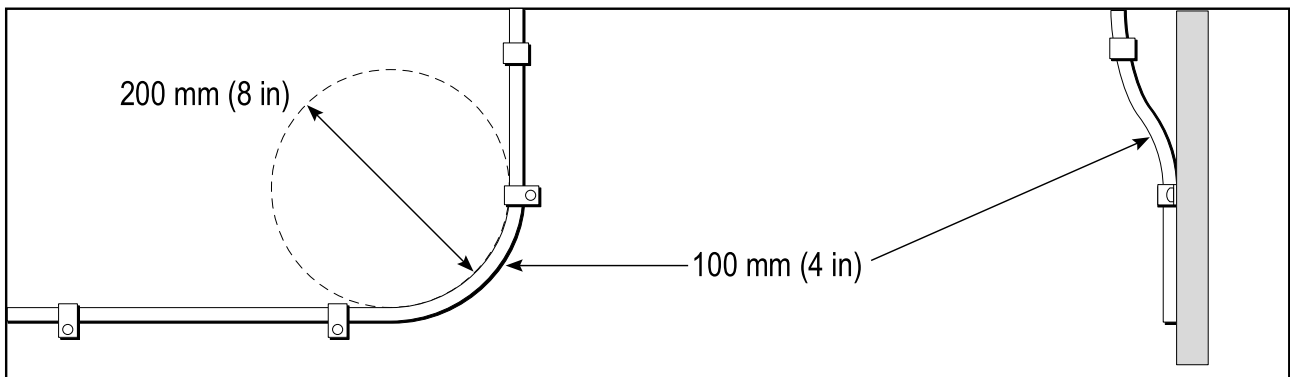

- Protect all cables from physical damage and exposure to heat. Use trunking or conduit where possible. Do NOT run cables through bilges or doorways, or close to moving or hot objects.
- Secure cables in place using tie-wraps or lacing twine. Coil any extra cable and tie it out of the way.
- Where a cable passes through an exposed bulkhead or deckhead, use a suitable watertight feed-through.
- Do NOT run cables near to engines or fluorescent lights.

Always route data cables as far away as possible from:

- other equipment and cables,
- high current carrying AC and DC power lines,
- antennas.

Strain relief

Ensure adequate strain relief is provided. Protect connectors from strain and ensure they will not pull out under extreme sea conditions.

Circuit isolation

Appropriate circuit isolation is required for installations using both AC and DC current:

- Always use isolating transformers or a separate power-inverter to run PC's, processors, displays and other sensitive electronic instruments or devices.
- Always use an isolating transformer with Weather FAX audio cables.
- Always use an isolated power supply when using a 3rd party audio amplifier.
- Always use an RS232/NMEA converter with optical isolation on the signal lines.
- Always make sure that PC's or other sensitive electronic devices have a dedicated power circuit.

Cable shielding

Ensure that all cables are properly shielded and that the cable shielding is undamaged.

Connections to other equipment

Requirement for ferrites on non-Raymarine cables

If your Raymarine equipment is to be connected to other equipment using a cable not supplied by Raymarine, a suppression ferrite **MUST** always be attached to the cable near the Raymarine unit.

Dust caps

To prevent potential water ingress, connectors not in use should be protected using the supplied dust caps.

Bare end wire connections

Your product is supplied with bare end wire connections. You must ensure that ALL bare end wires are adequately protected from short circuit and water ingress.

Bare ended wire connections

It is recommended that bare ended wire connections are made by soldering or using crimp connectors and then protected by wrapping the connection in insulation tape.

Unused bare ended wires

Any unused bare ended wires should be folded back and wrapped in insulation tape.

4.2 Connections overview

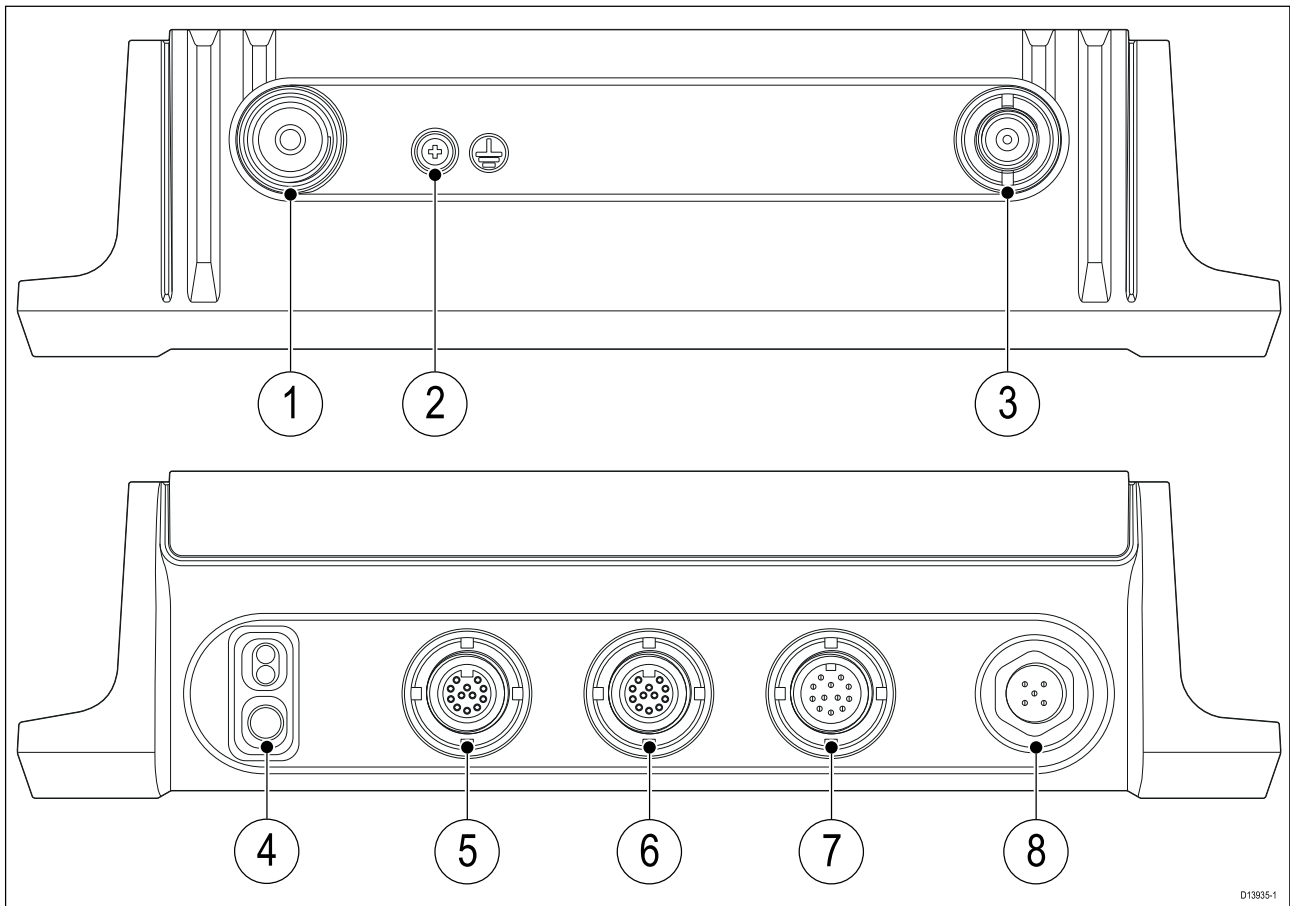

D13935-1

	Connection	Connects to	Suitable cables
1	GNSS (GPS) antenna connection	Passive GNSS antenna	GNSS antenna's fitted cable.
2	Earth stud	DO NOT CONNECT	N/A
3	VHF antenna connection	VHF antenna or Splitter	VHF antenna's fitted cable.
4	Power and data connection	<ul style="list-style-type: none"> • 12 V dc power supply • NMEA 0183 devices • Loud Hailer 	<ul style="list-style-type: none"> • Suitable power extension or circuit breaker. • cable supplied with your NMEA 0183 device • Loud hailer's fitted cable
5	HS 1 (Handset station 1) connection	Wired handset or Adaptor cable	Wired handset's fitted cable.
6	HS 2 (Handset station 2) connection	Wired handset or Adaptor cable	Wired handset's fitted cable.
7	Hub connection	Wireless hub connection	Wireless hub's fitted cable.
8	N2K (NMEA 2000) connection	SeaTalkng [®] / NMEA 2000 backbone	The supplied DeviceNet to SeaTalkng [®] adaptor or a DeviceNet spur cable.

4.3 Power connection

The power supply should be connected as shown below:

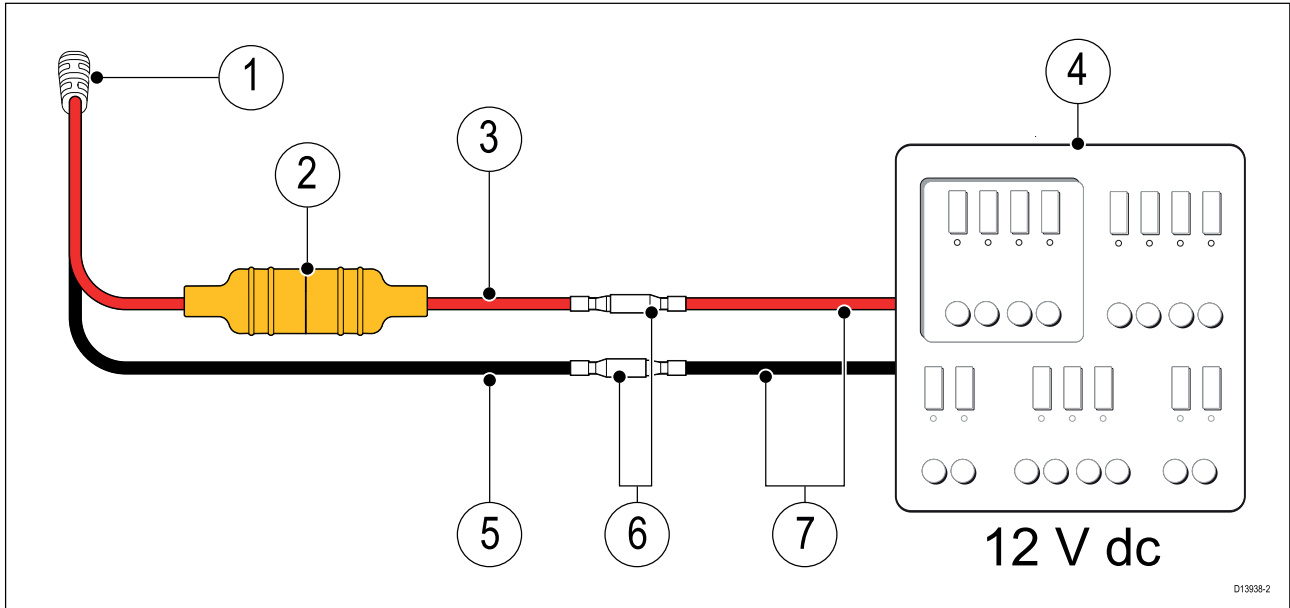

1. Radio's fitted power cable.
2. In-line fuse.
3. Power supply positive (+) Red wire
4. 12 V dc power source (i.e.: Distribution panel).
5. Power supply negative (-) Black wire.
6. Suitable waterproof connection (Radio is supplied with bullet crimps on power supply wires.)
7. If, required you can extend the power cable supplied with your radio, using suitably rated cabling.

 **Warning: 12 Volt dc only**
This product must only be connected to a **12 volt dc** power source.

 **Warning: Positive ground systems**
Do not connect this unit to a system which has positive grounding.

In-line fuse and thermal breaker ratings

The following in-line fuse and thermal breaker ratings apply to your product:

In-line fuse rating	Thermal breaker rating
10 A	7 A (if only connecting one device)

Note:

- The suitable fuse rating for the thermal breaker is dependent on the number of devices you are connecting. If in doubt consult an authorized **Raymarine**® dealer.
- Your product's power cable may have a fitted in-line fuse. If not, add an in-line fuse to the positive wire of your product's power connection.

Grounding

This product is grounded through the 0 V dc negative wire on the power cable and does not require a drain (shield) to be connected to the base station's ground terminal.

 **Warning: Chassis grounding**
Do NOT ground this product using the chassis ground terminal.
Grounding this product to a vessel's RF ground may cause galvanic corrosion.

Power distribution

Recommendations and best practice.

- The product is supplied with a power cable, either as a separate item or a captive cable permanently attached to the product. Only use the power cable supplied with the product. Do NOT use a power cable designed for, or supplied with, a different product.
- Refer to the *Power connection* section for more information on how to identify the wires in your product's power cable, and where to connect them.
- See below for more information on implementation for some common power distribution scenarios.

Important:

When planning and wiring, take into consideration other products in your system, some of which (e.g. sonar modules) may place large power demand peaks on the vessel's electrical system, which may impact the voltage available to other products during the peaks.

Note:

The information provided below is for guidance only, to help protect your product. It covers common vessel power arrangements, but does NOT cover every scenario. If you are unsure how to provide the correct level of protection, please consult an authorized Raymarine dealer or a suitably qualified professional marine electrician.

Implementation — direct connection to battery

- The power cable supplied with your product may be connected directly to the vessel's battery, via a suitably rated fuse or breaker.
- The power cable supplied with your product may NOT include a separate drain wire. If this is the case, only the power cable's red and black wires need to be connected.
- If the supplied power cable is NOT fitted with an inline fuse, you MUST fit a suitably rated fuse or breaker between the red wire and the battery's positive terminal.
- Refer to the inline fuse ratings provided in the product's documentation.
- If you need to extend the length of the power cable supplied with your product, ensure you observe the dedicated *Power cable extensions* advice provided in the product's documentation.

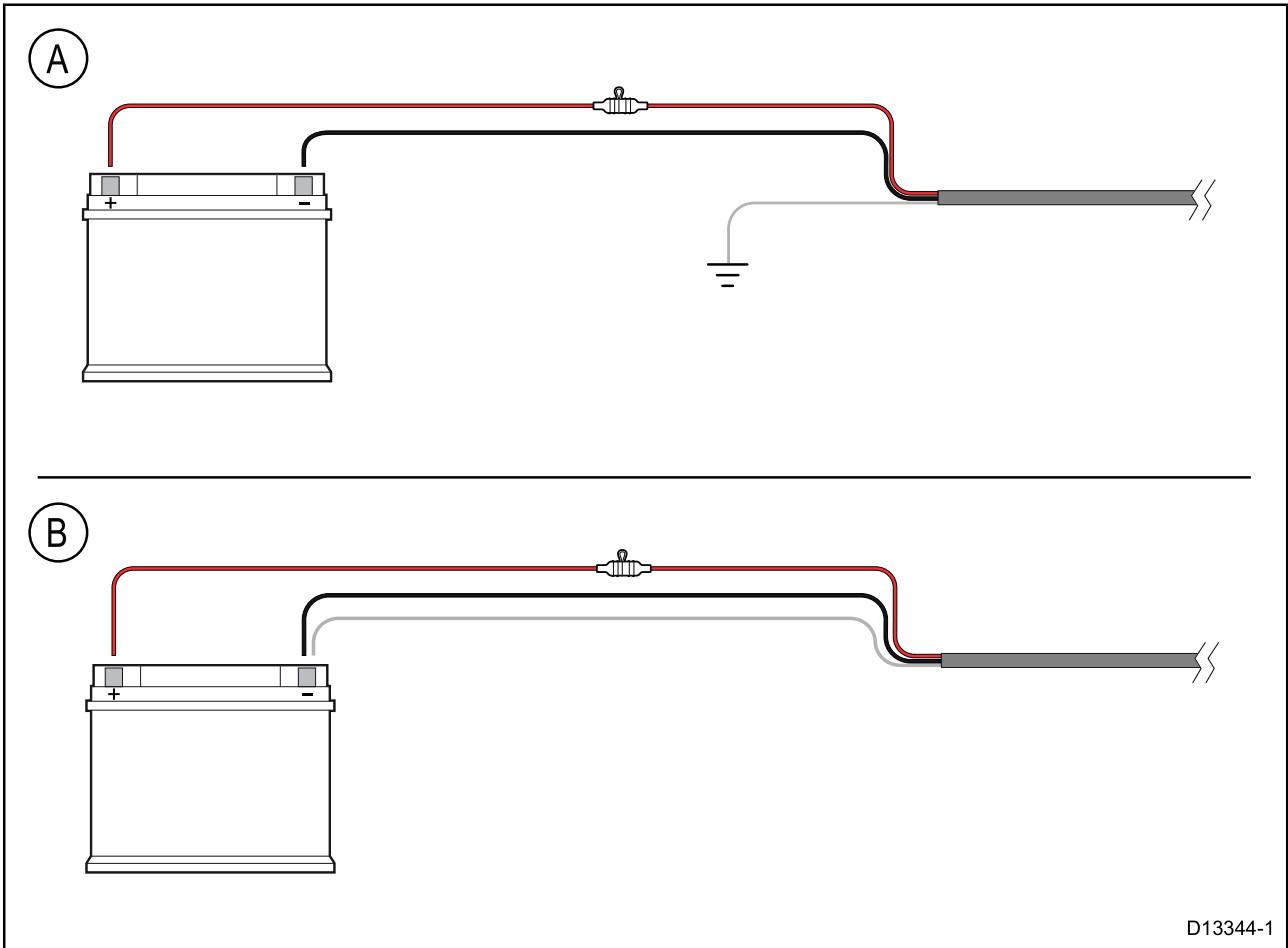

D13344-1

A	Battery connection scenario A: suitable for a vessel with a common RF ground point. In this scenario, if your product's power cable is supplied with a separate drain wire then it should be connected to the vessel's common ground point.
B	Battery connection scenario B: suitable for a vessel without a common grounding point. In this case, if your product's power cable is supplied with a separate drain wire then it should be connected directly to the battery's negative terminal.

Implementation – connection to distribution panel

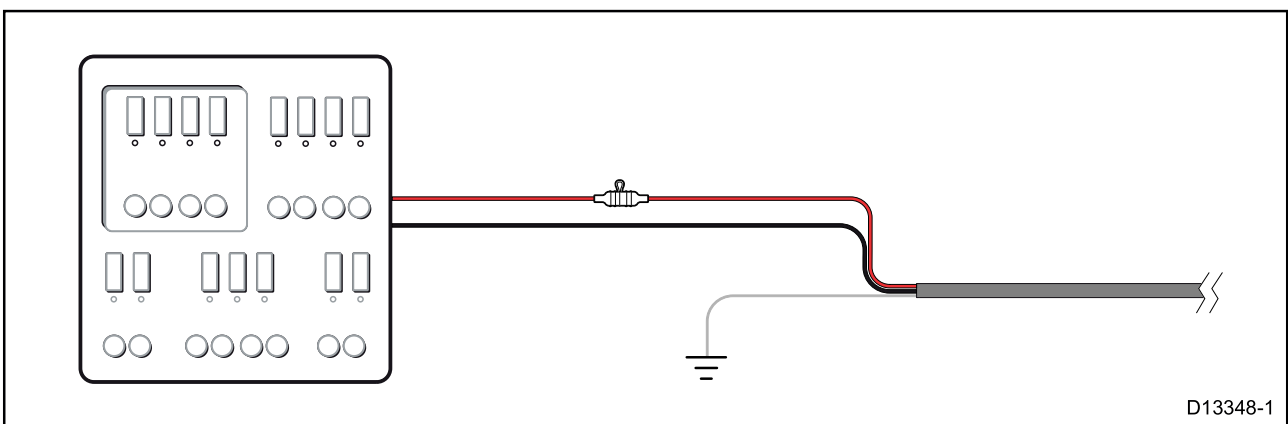

D13348-1

- Alternatively, the supplied power cable may be connected to a suitable breaker or switch on the vessel's distribution panel or factory-fitted power distribution point.
- The distribution point should be fed from the vessel's primary power source by 8 AWG (8.36 mm²) cable.
- Ideally, all equipment should be wired to individual suitably-rated thermal breakers or fuses, with appropriate circuit protection. Where this is not possible and more than 1 item of equipment shares a breaker, use individual in-line fuses for each power circuit to provide the necessary protection.

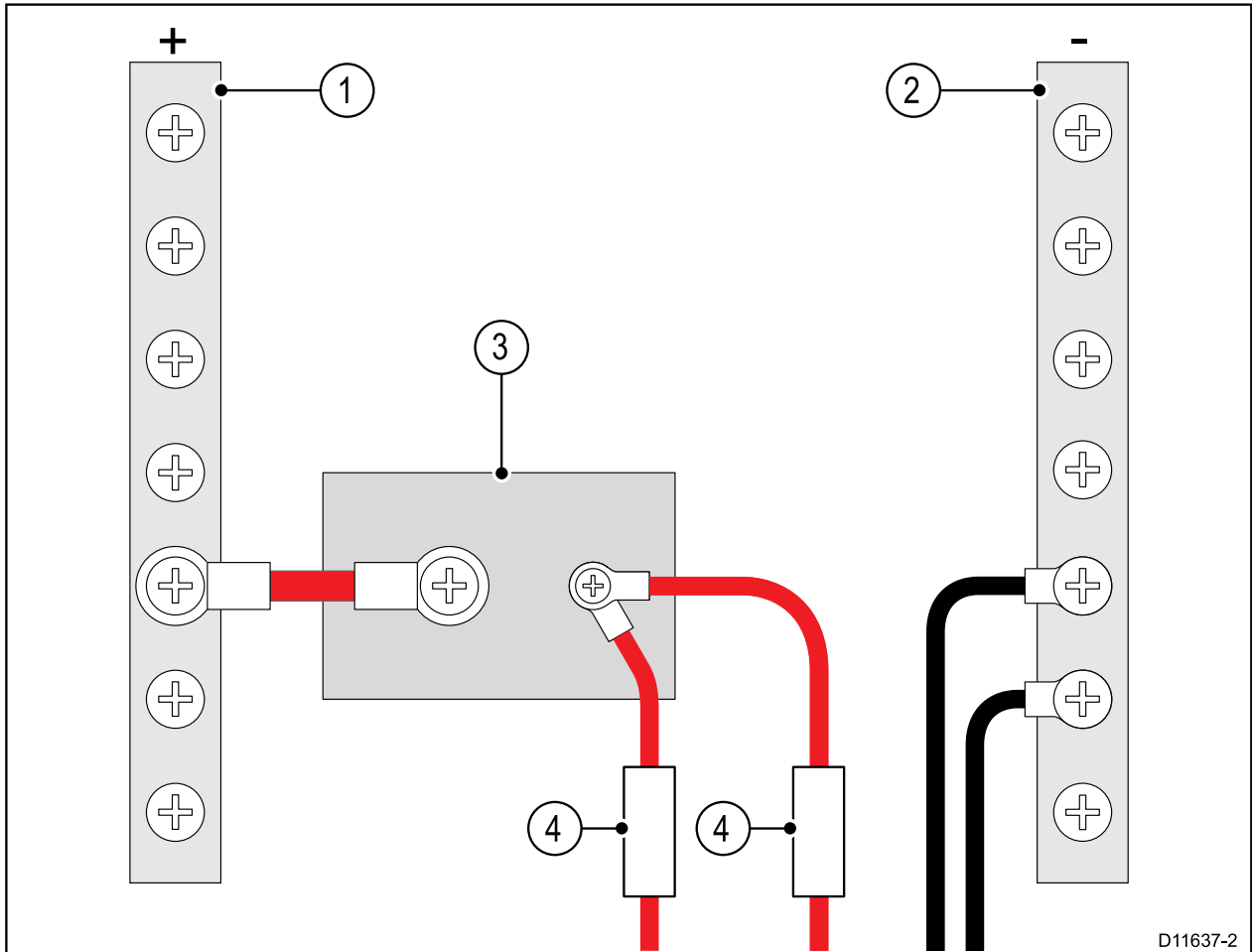

1	Positive (+) bar
2	Negative (-) bar
3	Circuit breaker
4	Fuse

- In all cases, observe the recommended breaker / fuse ratings provided in the product's documentation.

Important:
Be aware that the suitable fuse rating for the thermal breaker or fuse is dependent on the number of devices you are connecting.

Power cable extension

If you need to extend the length of the power cable supplied with your product, ensure you observe the following advice:

- The power cable for each unit in your system should be run as a separate, single length of 2-wire cable from the unit to the vessel's battery or distribution panel.
- For power cable extensions, a **minimum** wire gauge of 16 AWG (1.31 mm²) is recommended. For cable runs longer than 15 meters, you may need to consider a thicker wire gauge (e.g. 14 AWG (2.08 mm²), or 12 AWG (3.31 mm²)).
- An important requirement for all lengths of power cable (including any extension) is to ensure that there is a continuous **minimum** voltage at the product's power connector of 10.8 V dc, with a fully flat battery at 11 V dc.

Important: Be aware that some products in your system (such as sonar modules) can create voltage peaks at certain times, which may impact the voltage available to other products during the peaks.

Grounding

Ensure that you observe any separate grounding advice provided in the product's documentation.

More information

It is recommended that best practice is observed in all vessel electrical installations, as detailed in the following standards:

- BMEA Code of Practice for Electrical and Electronic Installations in Boats
- NMEA 0400 Installation Standard
- ABYC E-11 AC & DC Electrical Systems on Boats
- ABYC A-31 Battery chargers and Inverters
- ABYC TE-4 Lightning Protection

4.4 Handset station connection

A Wired handset can be connected to each Handset station connection (HS 1 / HS 2). Your radio is supplied with the equipment to create a full handset station (i.e.: Wired handset, Adaptor cable and Passive speaker). Additional accessories can be purchased to create a second wired handset station.

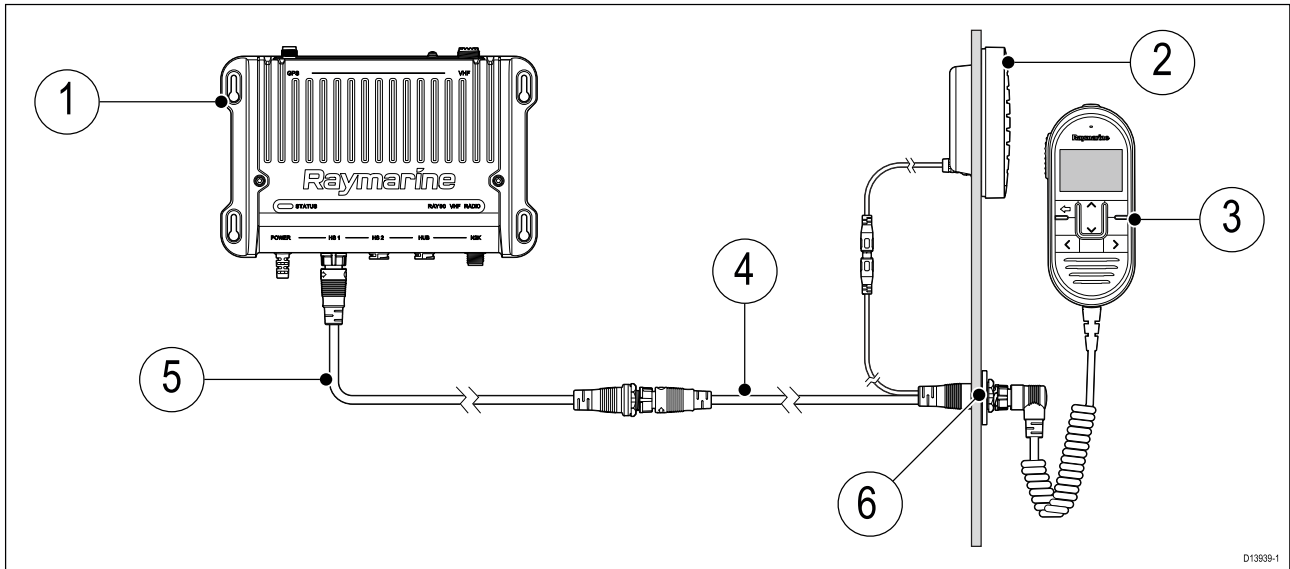

1. Base station
2. Passive speaker (1 x supplied and available as accessory: A80542)
3. Wired handset (1 x supplied and available as accessory: A80289)
4. Handset station adaptor cable with RCA Audio 400 mm (1.3 ft) (1 x supplied and available as accessory: A80297)
5. Wired handset extension cable (Available optional accessories: A80290 – 5 m, A80291 – 10 m or 15 – A80292)
6. Panel mount fixings kit (1 x supplied and available as a Spare: R70438)

Connecting handsets and cables

Follow the steps below to connect handsets and extension cables together.

1. If fitted, unscrew and remove the dust cap from the relevant connector.
2. Ensure the cable connectors are correctly orientated, before insertion.
3. Ensure connectors are fully inserted, before locking..
4. Tighten locking collars by Rotating clockwise.

Handset extension cables

Handset station cabling can be extended using approved extension cables.

The maximum length of cable from the Handset to the Base station should not exceed 50 m (164 ft)

4.5 Wired speaker connection

A wired speaker can be connected to a wired handset station using the RCA audio connector, available on the Handset adaptor cable.

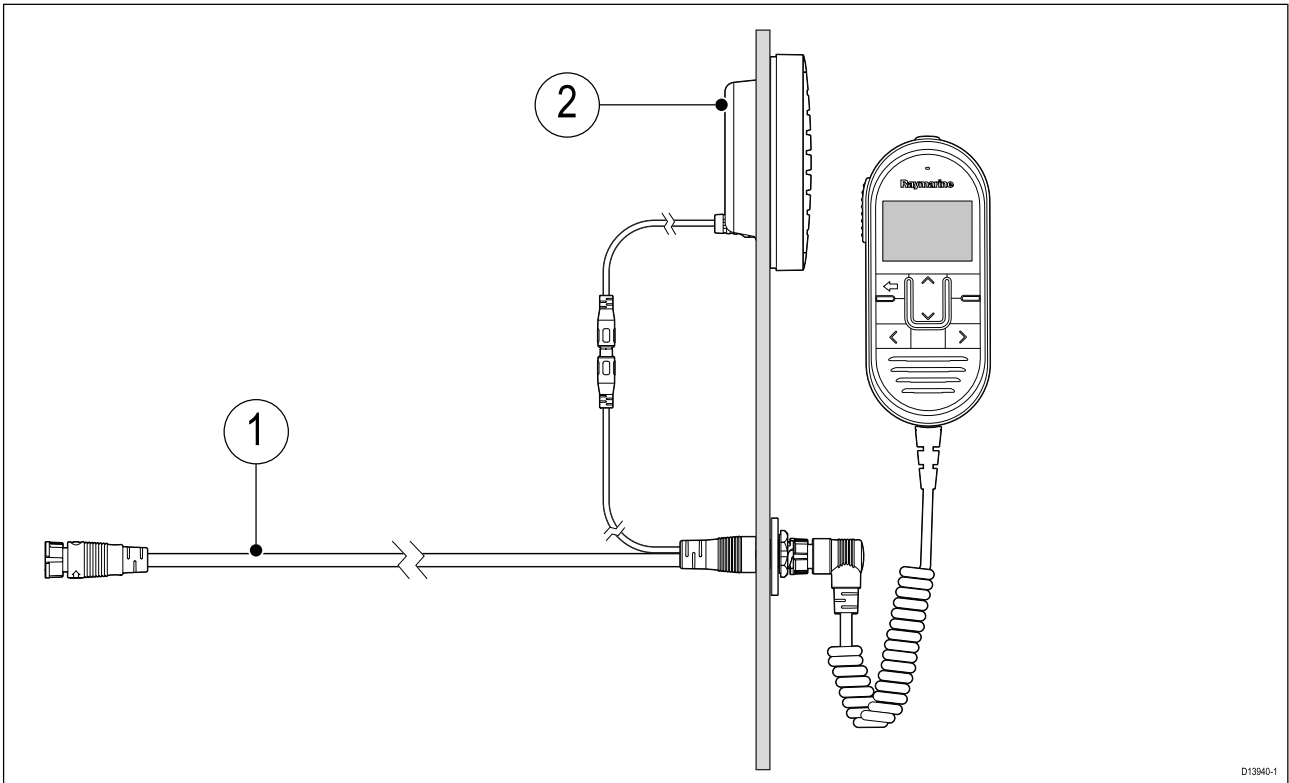

1. Wired handset adaptor cable 400 mm (1.3 ft) (1 x supplied and available as an accessory: A80297)
 2. Wired speaker (1 x supplied and available as an accessory: A80542)
- The wired speaker includes a 2m (6.56 ft) audio cable terminated with a male RCA connector.

4.6 NMEA 2000 / SeaTalkng[®] connection

Your product can transmit data to devices connected on SeaTalkng[®] or NMEA 2000 CAN bus networks. Connection is established using the DeviceNet connector located on the bottom of the unit.

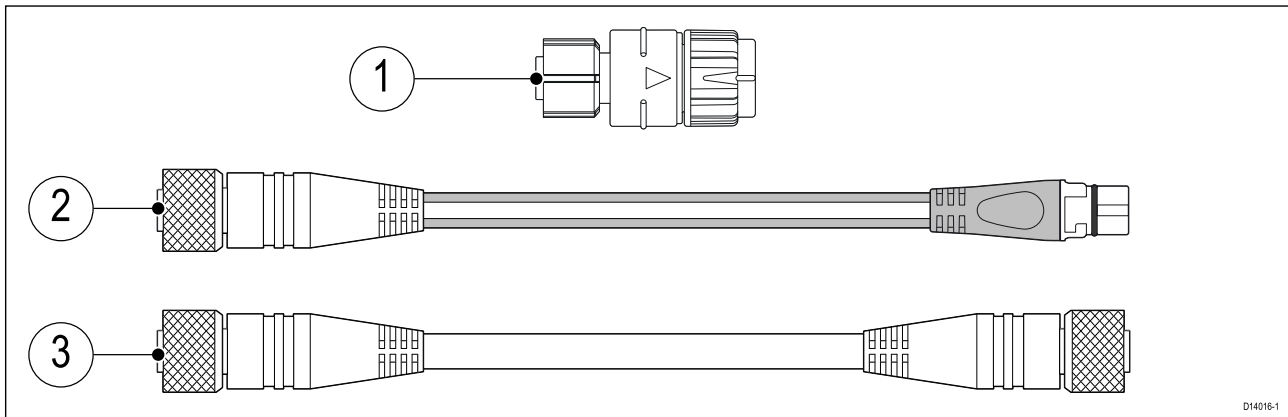

1. Use the supplied DeviceNet to SeaTalkng[®] adaptor to connect your product to your SeaTalkng[®] backbone using available SeaTalkng[®] spur cables.
2. You can also use a DeviceNet to SeaTalkng[®] adaptor cable (not supplied) to connect your product to an available spur on your SeaTalkng[®] backbone.
3. Alternatively you can connect your product to a NMEA 2000 backbone using a standard DeviceNet cable (not supplied).

Refer to [Chapter 14 Spares and accessories](#) for a list of available SeaTalkng[®] cables.

Note:

1. The product must be connected to a correctly terminated backbone.
2. You cannot connect your product directly to a MFD.
3. Refer to the instructions supplied with your SeaTalkng[®] / NMEA 2000 device for details on creating a backbone.

Connecting SeaTalkng[®] cables

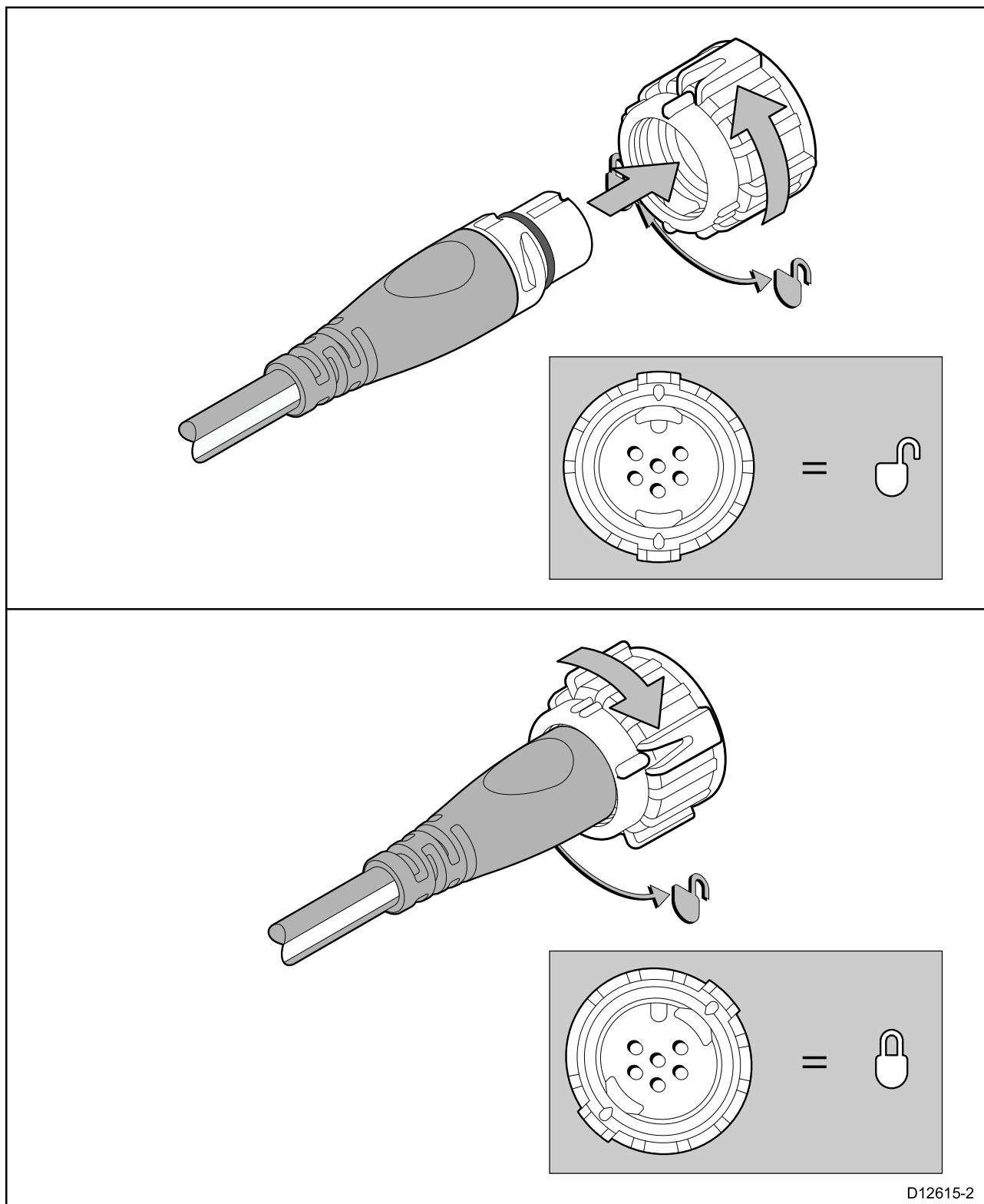

D12615-2

1. Rotate the locking collar so it is in the unlocked position.
2. Ensure the cable's connector is correctly oriented.
3. Fully insert the cable connector.
4. Rotate locking collar clockwise (2 clicks) until it is in the locked position.

4.7 NMEA 0183 connection

The NMEA 0183 wires can be used to connect the unit to a NMEA 0183 GNSS (GPS) receiver or MFD.

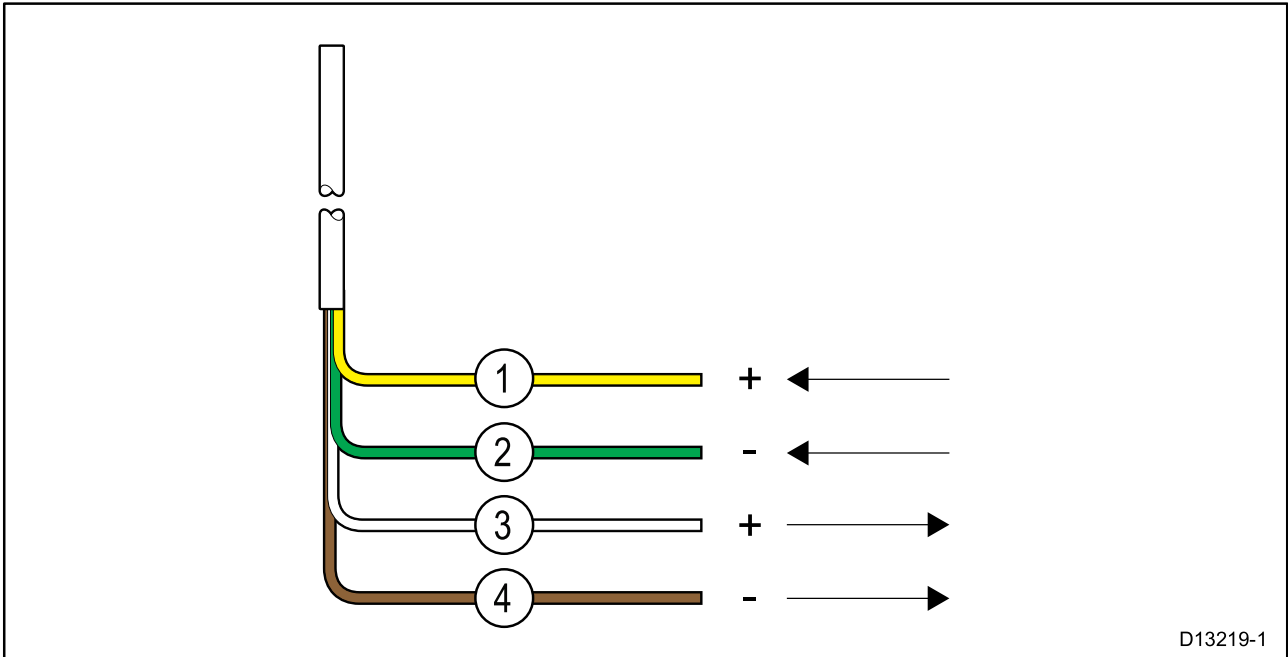

1. Yellow = Receive positive (+) wire
2. Green = Receive negative (-) wire
3. White = Transmit positive (+) wire
4. Brown = Transmit negative (-) wire

The NMEA wires should be connected to a compatible device as shown in the table below:

NMEA 0183 wires		NMEA 0183 device
Receive positive (+)	to	Transmit positive (+)
Receive negative (-)	to	Transmit negative (-)
Transmit positive (+)	to	Receive positive (+)
Transmit negative (-)	to	Receive negative (-)

4.8 Loud hailer connection

A Loud hailer (M95435) can be connected to the radio using the loud hailer wires.

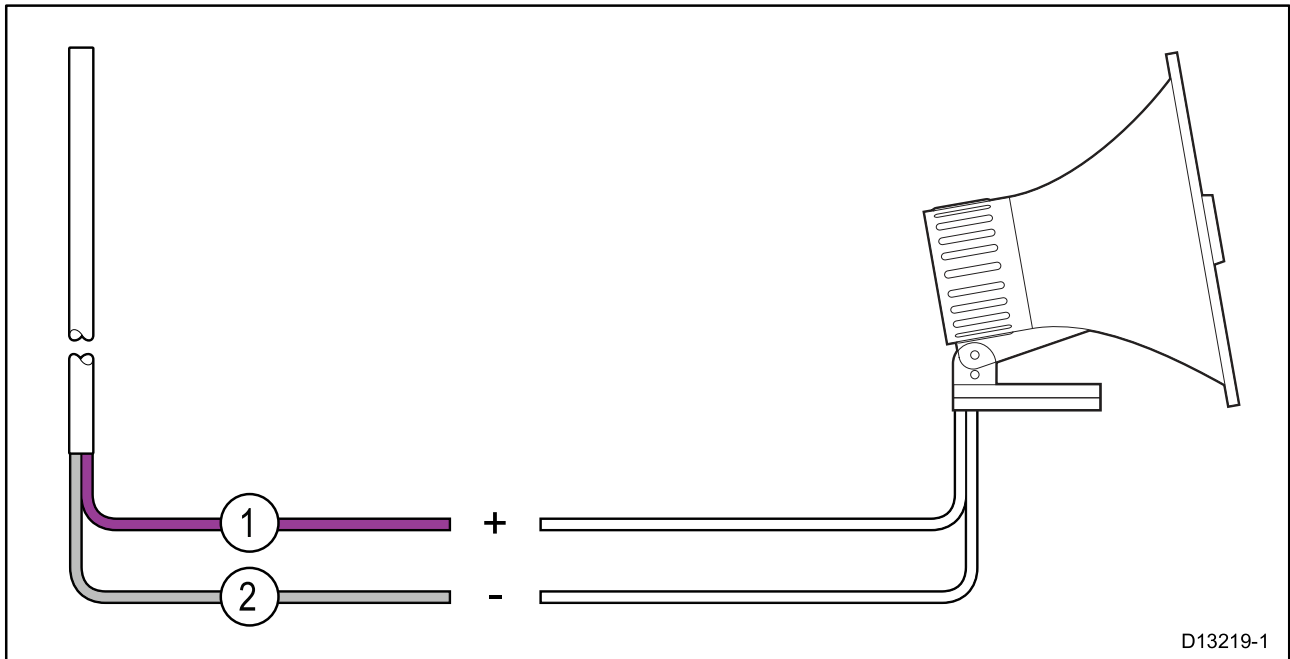

1	Positive (+) hailer wire (Purple)
2	Negative (-) hailer wire (Gray)

4.9 Connecting GNSS (GPS) and VHF antennas

Your radio requires a VHF antenna to function as a radio. If you intend to use the radio's internal GNSS (GPS) receiver then you will also require a GNSS (GPS) passive antenna to be connected. The antenna connections can be protected so that they cannot come into contact with any grounded bare metal. This is especially important when installing the radio on metal structure.

Pre-requisites:

- Ensure you have installed your antennas in accordance with the instructions supplied with the antennas.
- Ensure the cables have been properly routed to the Base station and that sufficient cable length is available to make the connections.

Note:

- Follow steps 2 and 3 to install the antennas with no protection.
- When mounting the Base station on metal structure, in order to prevent galvanic corrosion, ensure ALL steps are followed so that the antennas are isolated from the vessel's metalwork.

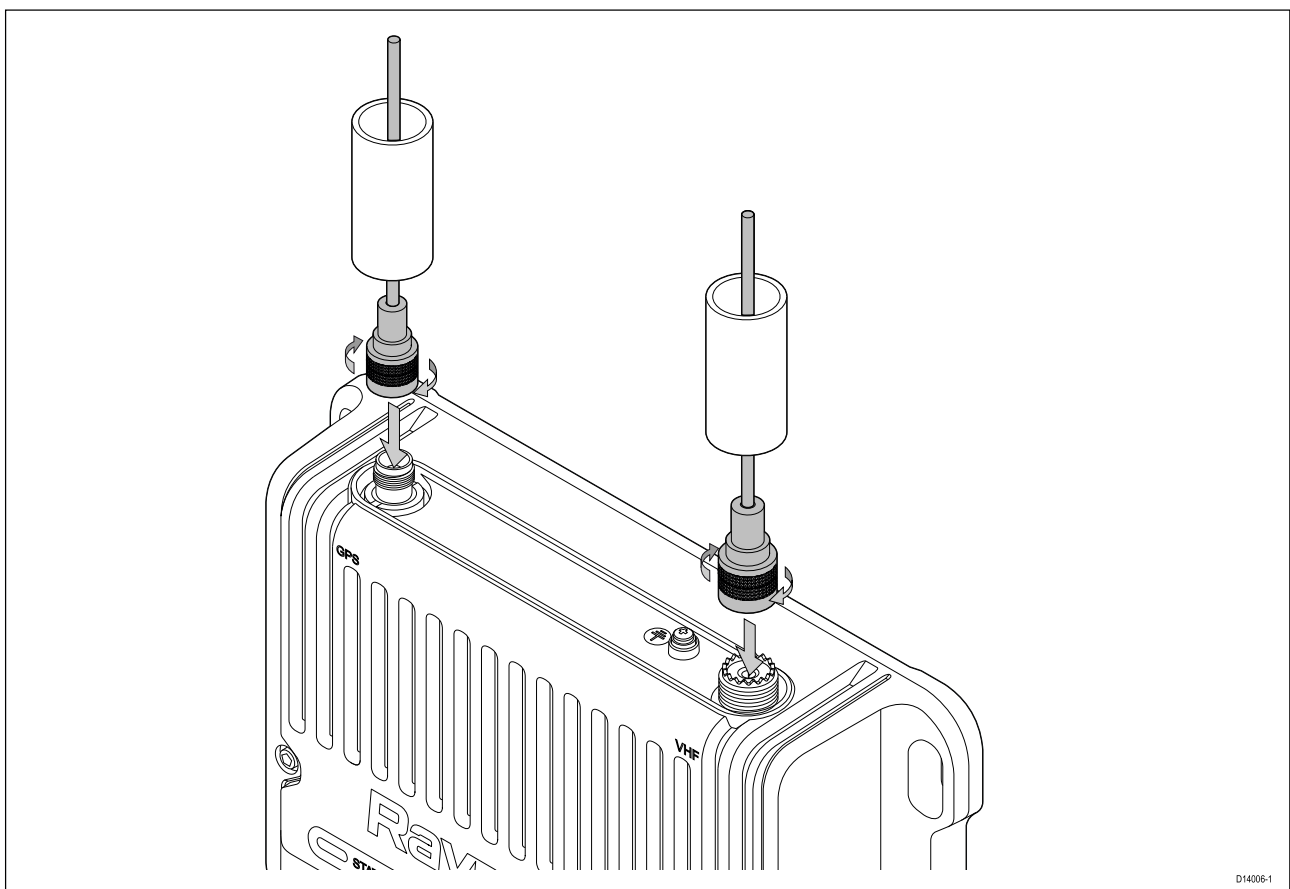

D14006-1

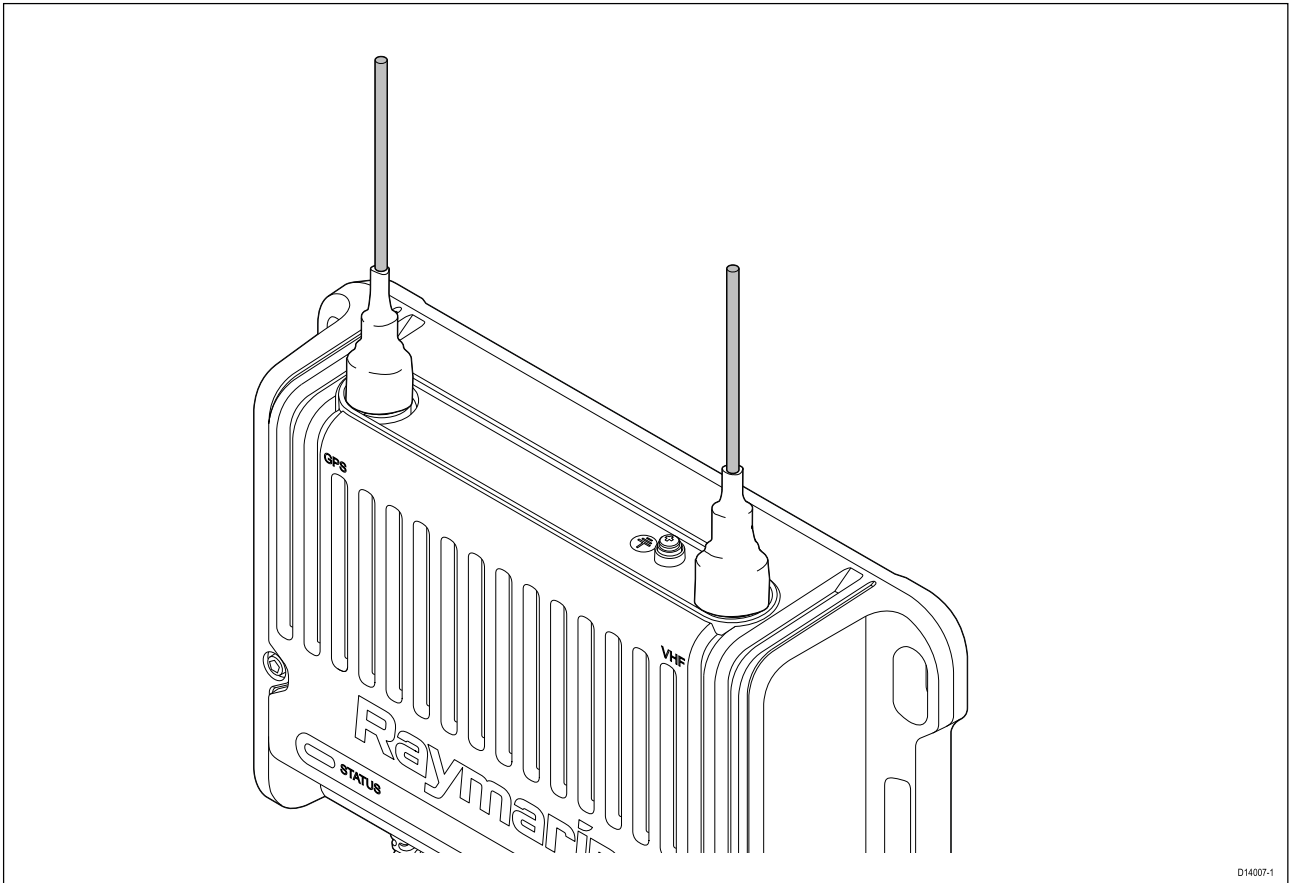

D14007-1

1. Feed the supplied heat shrink tubes over the connector ends of your antennas.
2. Plug the antenna connectors into the relevant antenna connections on the Base station.
3. Secure by tightening the locking collars.
4. Pull the heat shrink tubes down over the antenna connector, ensuring the connectors are fully covered.
5. Apply heat evenly over the heat shrink tubes until they are shrunk uniformly and resemble the shape of the connectors.

4.10 Wireless hub connection

The Wireless hub connects directly to the Ray90 / Ray91's Hub connection.

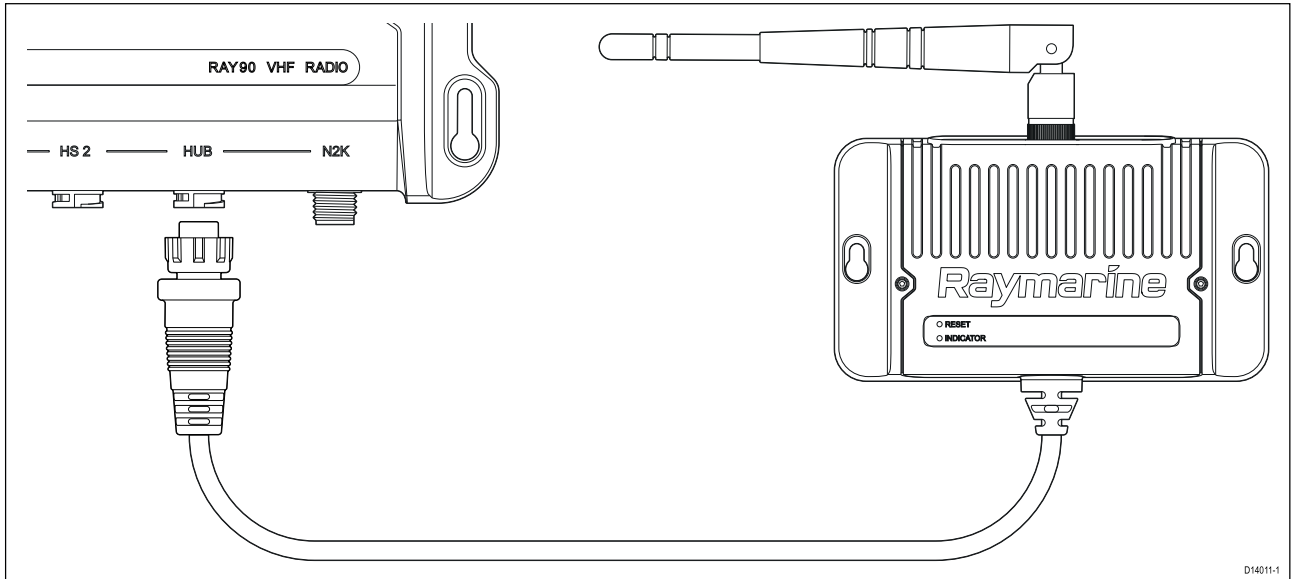

The Wireless hub is required to allow connection of wireless handset stations to the Ray90 / Ray91 base station.

4.11 Wireless handset charging holster – power connection

To enable inductive charging of the wireless handset, the holster requires a 12 V dc power supply. The power cables should be connected via a distribution panel or, if required directly to a battery.

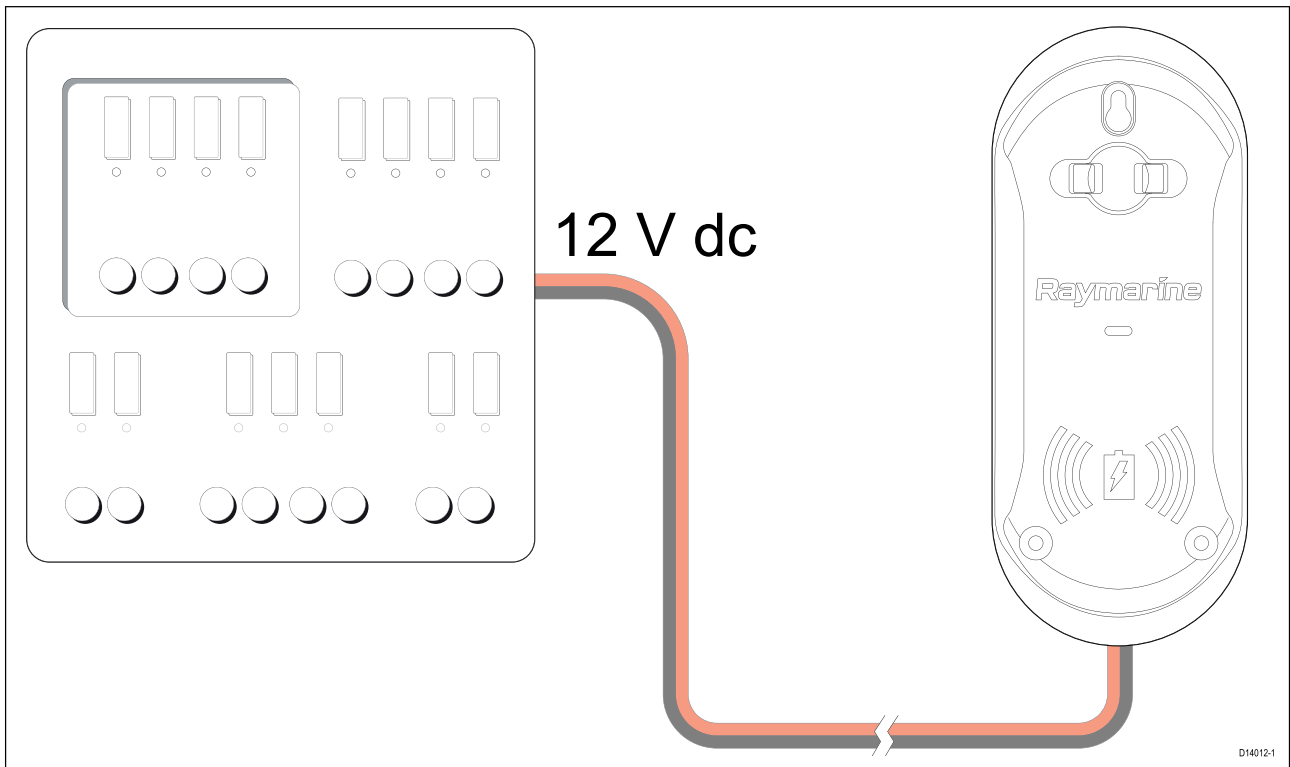

Refer to the [Power distribution](#) section for guidance on connecting to a power supply.

In-line fuse and thermal breaker ratings

The wireless speaker is internally fused, however it is recommended that you fit an inline fuse on the positive wire of your product's power cable or connect using a thermal breaker.

In-line fuse rating	Thermal breaker rating
2 A	2 A (refer to note below)

Note:

- The suitable fuse rating for the thermal breaker is dependent on the number of devices you are connecting. If in doubt consult an authorized Raymarine® dealer.

4.12 Wireless handset connections

The Wireless handset connects wirelessly to the Wireless hub, and the Wireless speaker connects wirelessly to the Wireless handset.

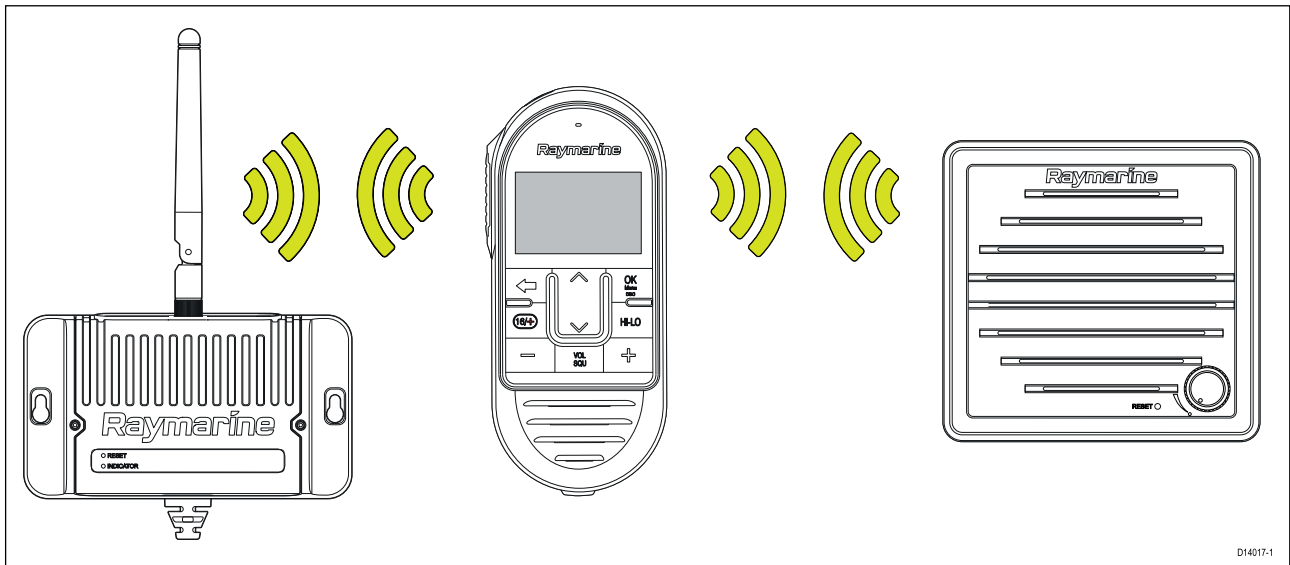

Up to 3 Wireless handsets can be connected to the Wireless hub. Refer to [6.2 Connecting a wireless handset to the hub](#) for the connection procedure.

One Wireless speaker can be connected to each Wireless handset. Refer to [6.3 Connecting the wireless speaker to the Wireless handset](#) for the connection procedure.

4.13 Wireless speaker – power connection

The wireless speaker is an active speaker that requires a 12 V dc power supply. The power cables should be connected via a distribution panel or, if required directly to a battery.

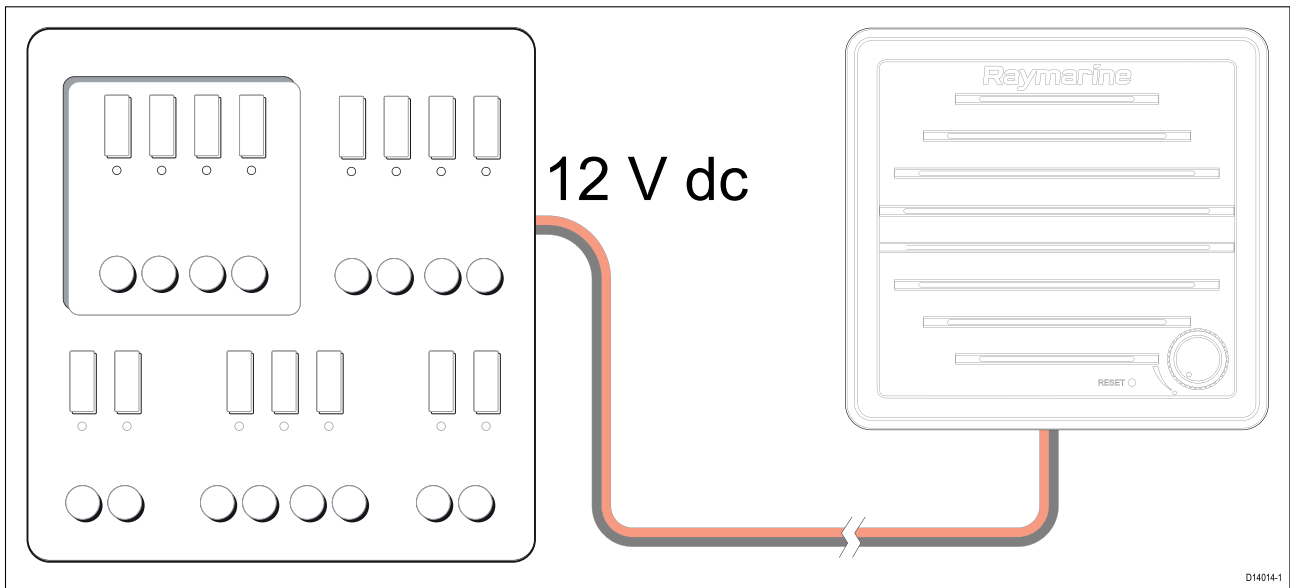

Refer to the [Power distribution](#) section for guidance on connecting to a power supply.

In-line fuse and thermal breaker ratings

The wireless speaker is internally fused, however it is recommended that you fit an inline fuse on the positive wire of your product's power cable or connect using a thermal breaker.

In-line fuse rating	Thermal breaker rating
2 A	2 A (refer to note below)

Note:

- The suitable fuse rating for the thermal breaker is dependent on the number of devices you are connecting. If in doubt consult an authorized Raymarine® dealer.

Chapter 5: Getting started

Chapter contents

- 5.1 Handset controls on page 76
- 5.2 Powering the Base station on page 78
- 5.3 Homescreen overview on page 79
- 5.4 Multiple station operation on page 86
- 5.5 Adjusting Brightness and Contrast on page 87
- 5.6 Shared Brightness on page 88
- 5.7 Initial set up on page 90
- 5.8 Selecting a language on page 91
- 5.9 Switching on the AIS receiver on page 92
- 5.10 Selecting a network type on page 93
- 5.11 Entering your MMSI number on page 94
- 5.12 Entering your ATIS ID on page 96
- 5.13 Changing the radio region on page 98
- 5.14 Switching between high and low transmit power on page 99
- 5.15 GNSS (GPS) set up on page 100

5.1 Handset controls

Overview of wireless handset controls.

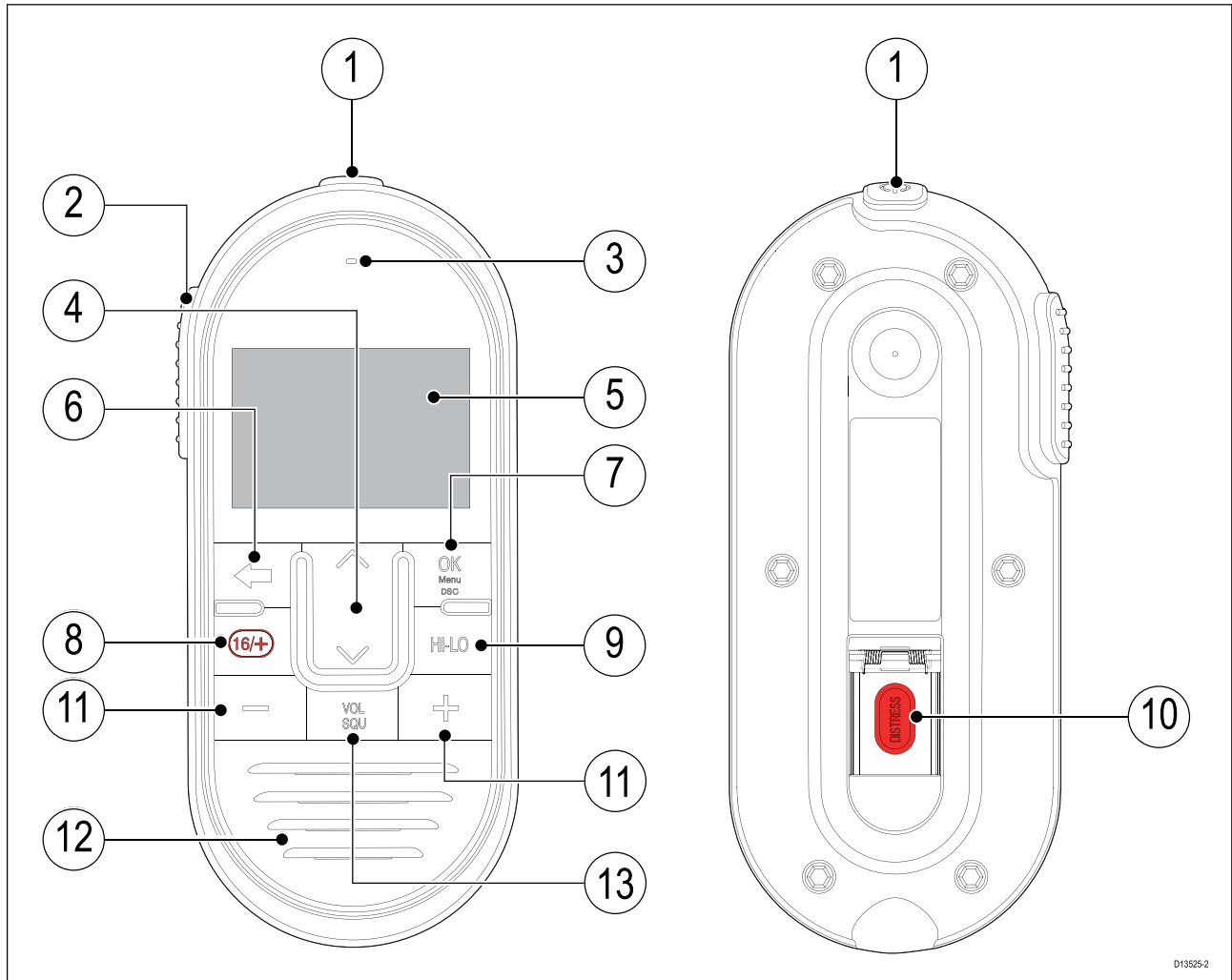

1. **Power** — Press to power the handset on. Press and hold for 3 seconds to power the handset off. Momentary press to access the shortcut list.
2. **PTT (Push to Talk)** — Press and hold to send a voice message. Release to return to receive mode.

Note: The maximum transmit time is limited to 5 minutes to prevent unintentional transmissions from occupying the VHF channel.

3. **Microphone location**
4. **Channel Up** and **Channel Down** — Changes to the next or previous VHF channel, also used to select or adjust options in the menu.
5. **LCD display**
6. **Back** — Go to the previous menu / screen. Press and hold to return to the Homescreen.
7. **OK / menu button** — Press button to access menu / DSC functions and to confirm selections.
8. **16 / +** — When powered on press to switch between priority channels.
9. **HI/LO** — Press to switch between High (25 W) and Low (1 W) transmit power.
10. **DISTRESS** — Lift up the spring-loaded cover and press this button to make a DSC distress call.
11. **Volume Up** and **Volume Down** — Press to adjust volume or squelch intensity up or down.
12. **Built-in speaker**
13. **VOL/SQ** — Press button to switch between volume and squelch controls.

Wireless speaker controls

The controls for the Wireless active speaker are shown below.

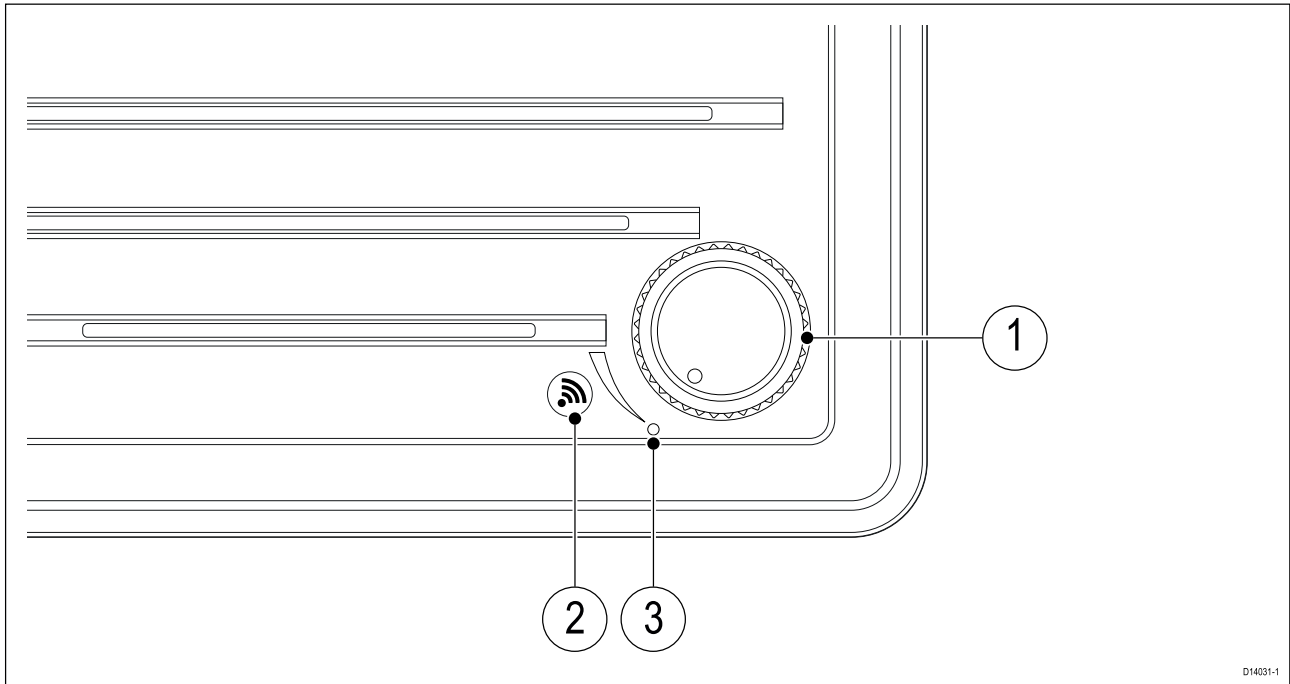

1. On/Off and volume control — Turn clockwise to turn on and then increase speaker volume. Turn counter-clockwise to decrease volume and then turn off.
2. **Pairing** button — Press to place speaker in pairing mode. Pressing the **Pairing** button will also disconnect the speaker from the device it is currently connected to.
3. LED diagnostics and status indicator.

5.2 Powering the Base station

The Base station automatically powers up when connected to a suitable power supply.

The Base station is powered down by unplugging from the power supply or, if applicable, by tripping it's circuit breaker.

Powering the handset

To power the Handset on and off follow the steps below.

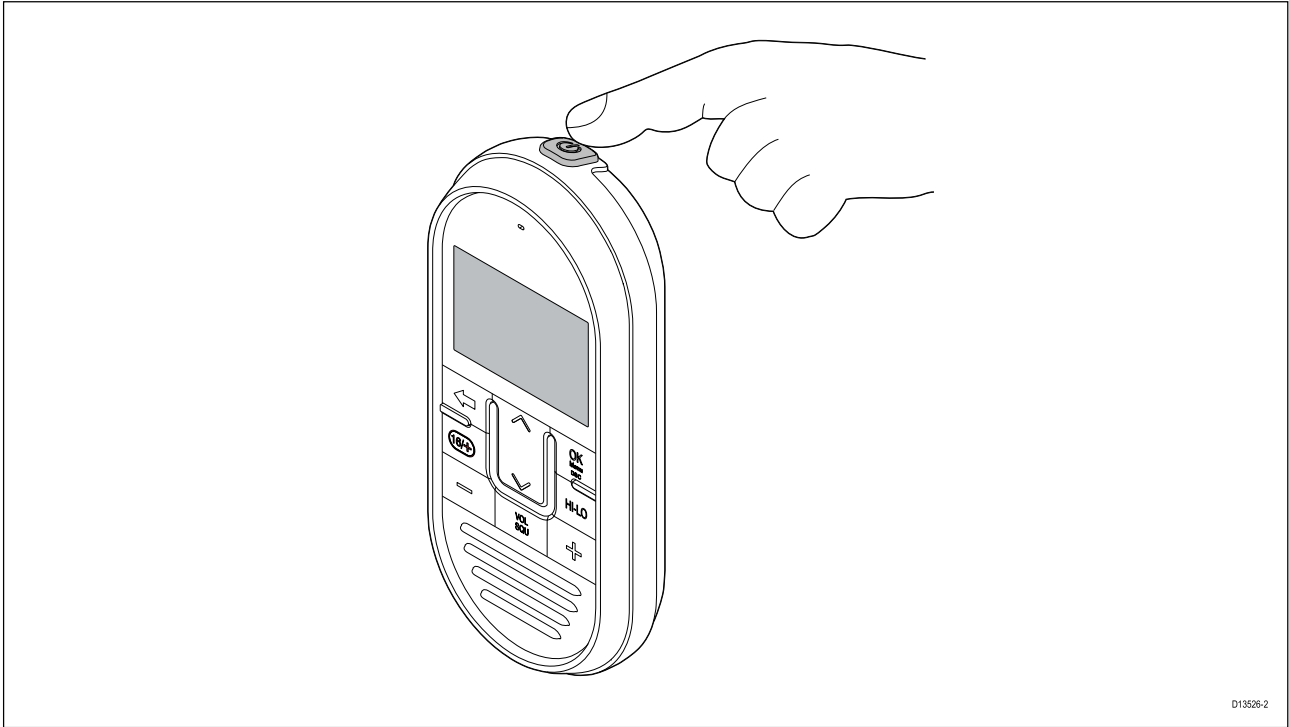

D13526-2

With the Base station powered On:

1. Press and hold the **Power** button, located on the top of the Handset, for 2 seconds.
The Handset will power on.
2. To power off the Handset, press and hold the **Power** button for approximately 3 seconds, until the screen turns off.

5.3 Homescreen overview

The information below describes the on-screen characters and symbols which are shown on the Homescreen..

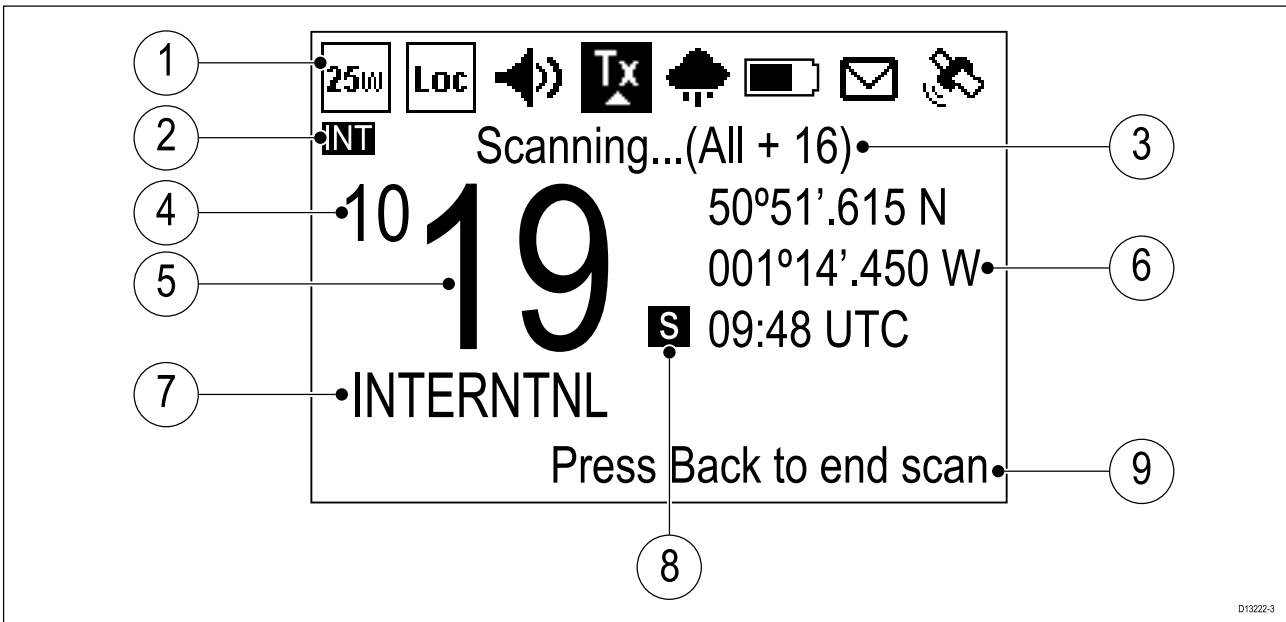

1. **Status bar** — The status bar displays symbols which indicate the current status of the unit.
2. **Frequency band** — Indicates which channel frequency band is in use:
 - USA — United States of America
 - INT — International
 - CAN — Canada
 - WX — Weather



Note: Special licensing is required to receive USA and Canadian channel sets.

3. **Status text** — Indicates the current radio mode e.g.: ATIS Mode active, Weather Alert, Scan mode etc.
4. **New 4 digit channels** — Identifies the first 2 digits when the radio is set to one of the new 4 digit simplex channels.
5. **Channel** — Indicates the current channel number, or the last 2 digits when set to a 4 digit channel..
6. **Location / Time** or **Location / COG/SOG** — Depending on selection displays Location coordinates and current time or Location coordinates and current COG and SOG.
7. **Channel Name** — Indicates the name of the current channel.
8. **Channel type** — Indicates the type of channel:
 - **s** = Simplex — Simplex channels transmit and receive on the same frequency.
 - **d** = Duplex — Duplex channels use separate frequencies to transmit and receive.
9. **Optional text** — Provides extra user guidance.

Status bar symbols

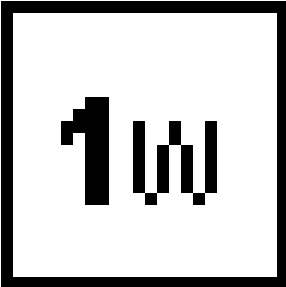
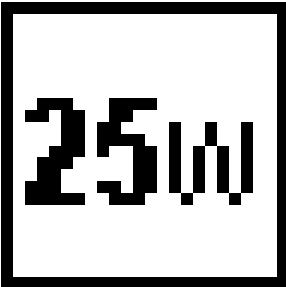
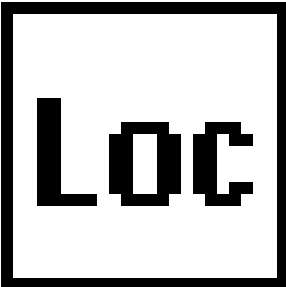
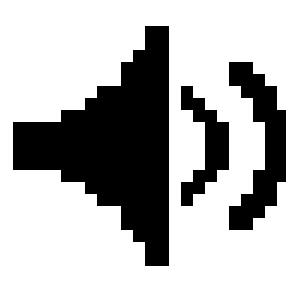
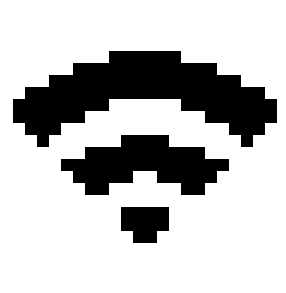
The status bar is used to display symbols that indicate the radio's status.

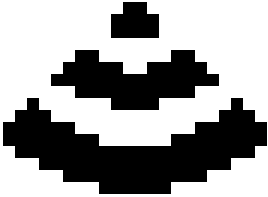
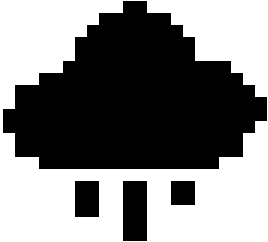
Symbol	Name	Description
	Low power	Indicates the radio transmitters is in low power (1 watt) or high power (25 watt) mode
	High power	
	Local	Indicates the radio is in local reception mode, which decreases receiver sensitivity in high traffic areas to decrease unwanted reception
	Fog horn	Indicates that the radio is in Fog horn mode.
	Transmit	Indicates the radio is currently transmitting (e.g. the PTT button is being pressed.)

Symbol	Name	Description
	Receive	Indicates the radio is currently receiving a transmission
	Weather	Indicates that the weather alerts mode is activated.
	Power supply voltage too low	Indicates the power supply to the radio is below the specified operating voltage.
	Power supply voltage too high	Indicates the power supply to the radio is above the specified operating voltage.

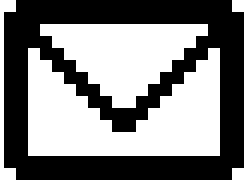
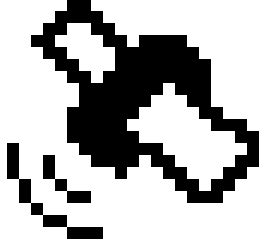
Symbol	Name	Description
	DSC	Indicates that a DSC call has been received
	GPS Fix	Indicates if the radio has a GPS/GNSS fix.

Main menu overview

The main menu is accessed by Pressing the **OK** button from the **Homescreen**.

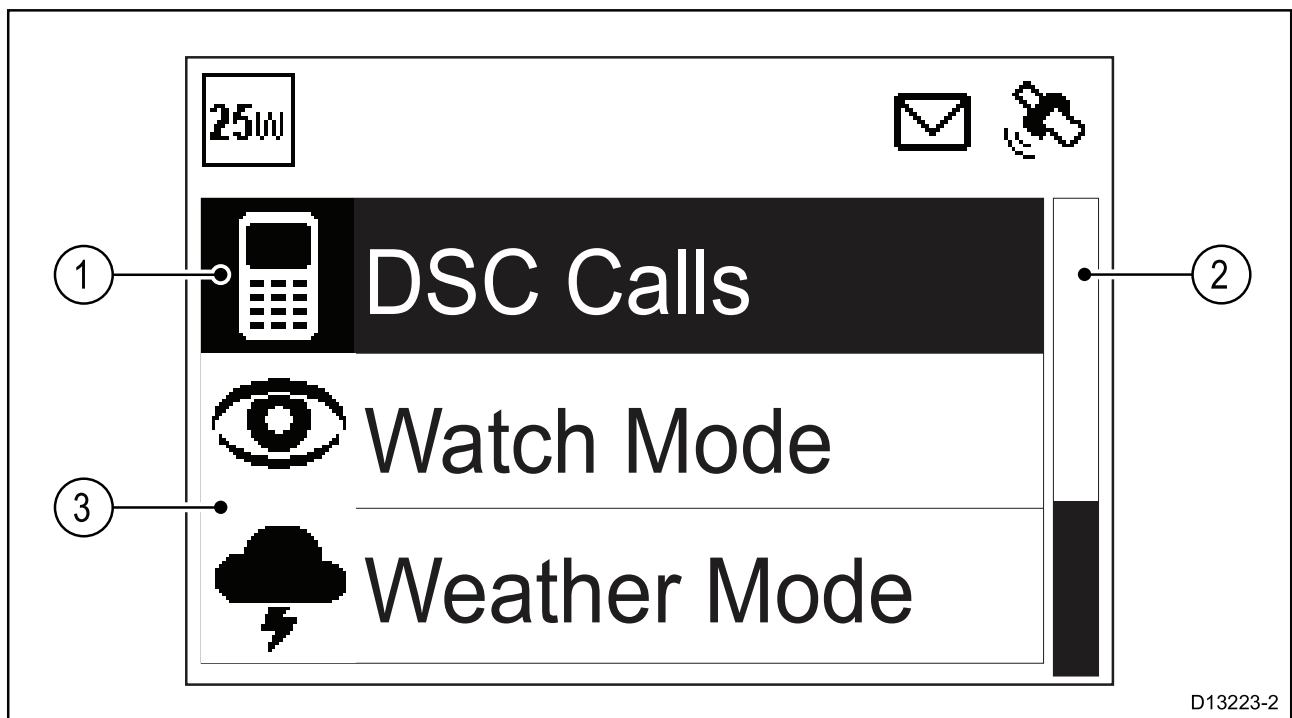

1. Currently selected menu item
2. Scroll bar
3. Menu items

The main menu includes the following items:

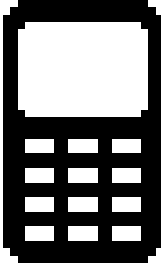
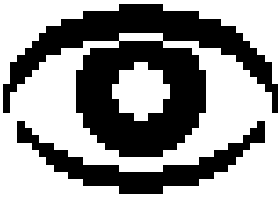
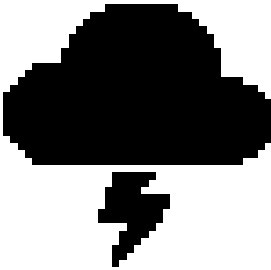
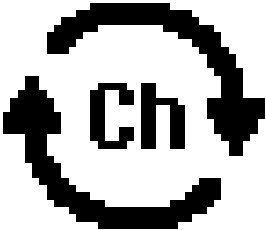
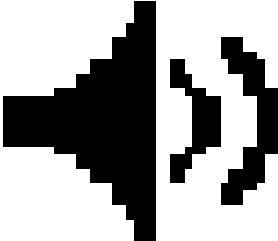
Symbol	Name	Sub-options
	<p>* DSC Calls</p>	<ul style="list-style-type: none"> • Individual call • Distress call • Position request • Group call • All ships call • Phonebook • Call logs • Test call • DSC set-up
	<p>* Watch Mode</p>	<ul style="list-style-type: none"> • Dual watch • Triple watch • 2nd priority channel
	<p>* Weather Mode</p>	<ul style="list-style-type: none"> • Weather Homescreen
	<p>* Scan Mode</p>	<ul style="list-style-type: none"> • All channels • All channels + 16 • Saved channels • Saved channels + 16 • Edit saved channels
	<p>** Hail/Fog/Intercom</p>	<ul style="list-style-type: none"> • Hailer • Fog horn • Intercom

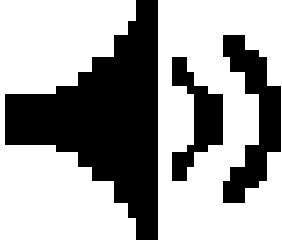
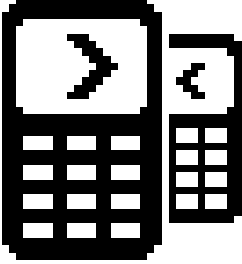
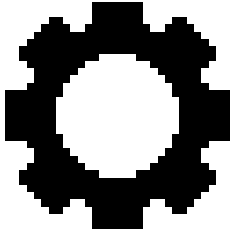
Symbol	Name	Sub-options
	** Hailer/Fog horn	<ul style="list-style-type: none"> • Hailer • Fog horn
	** Intercom	<ul style="list-style-type: none"> • Intercom
	Set-up	<ul style="list-style-type: none"> • Display set-up • Language • Units • Power output • Sensitivity • Noise cancelling (Tx) • ** Wireless set-up • Handset name • Key beep • Channel set-up • Weather alerts • GPS set-up • DSC set-up • AIS • Network output • ATIS set-up • Maintenance

Note:

* Menu items not available when radio has ATIS enabled or if the radio has been pre-programmed in MARCOM-C mode.

** Menu only available when compatible accessories are connected.

Dealer set-up menu options

With authorised Dealer hardware connected the Dealer set-up menu will be available from the Main menu.

Menu item	Description	Options
MMSI	Enables editing or removal of the stored MMSI number.	Edit screen
ATIS	Enables editing or removal of the stored ATIS ID.	Edit screen
Frequency bands	Enables the dealer to select the frequency bands that are available to the user. Bands not selected will NOT be available in the Frequency band menu that is available to users.	<ul style="list-style-type: none">• International• USA• Canada• Weather channels
Feature on/off	Enables the dealer to select whether certain features are available to the user. Features not selected will NOT be available to users.	<ul style="list-style-type: none">• Scan• Dual / Tri watch• Distant / Local• Private channels

5.4 Multiple station operation

When more than one handset station is connected, other handsets become “repeater” displays and will mirror the display of the handset in use.

Other handsets cannot take control of the radio whilst another handset is in use. Other handsets can take control of the radio after the last used handset has been inactive for 3 seconds or more.

5.5 Adjusting Brightness and Contrast

The LCD Brightness (Backlight) and Contrast can be adjusted using the Shortcuts list.

From any screen:

1. Press the **Power** button.
2. Select **Backlight** or **Contrast**.
3. Adjust the Backlight or Contrast to the desired level using the Handset's **Channel Up** / **Channel Down** buttons.
4. Press the **Back** button to return to the previous screen.

The Backlight and Contrast settings can also be accessed from the Display set-up menu: **Menu** > **Set-up** > **Display set-up** .

5.6 Shared Brightness

You can set up Shared Brightness groups which enables simultaneous brightness adjustment of all units that are part of the same group.

The following products are compatible with Shared Brightness:

- LightHouse™ 3 MFDs using software version 3.4 or greater.
- LightHouse™ or LightHouse™ 2 powered MFDs.
- SeaTalkng® Instrument displays and Pilot controllers.
- SeaTalkng® VHF DSC Radios.

Any adjustments to the Shared Brightness level will be reflected on all units assigned to the same group.



Multiple brightness groups can be configured. These groups could be used to reflect the physical location of units on your vessel. For example, the units at your helm can be set to one group, and the units on the flybridge can be set to a different group.

Shared Brightness requires:

- all units to be compatible with the Shared Brightness function (see list of compatible units above).
- the **Shared brightness** setting set to On for all units in the brightness group.
- units to be assigned to Network Groups.
- all the displays in that group to be synchronized.

Enabling Shared Brightness

From the **Display Set-up** menu: (**Menu > Set-up > Display Set-up**).

1. Select **Shared Brightness**.
2. Select **Shared Brightness** again to enable Shared Brightness.

If Shared Brightness is already enabled then selecting this menu item will disable Shared Brightness.

3. Select **Group**.
4. Select the group that you want to assign the radio to.

Adjusting the Brightness setting will now change the brightness of all products assigned to that group.

5.7 Initial set up

Unless your radio has been pre-programmed; the first time you power-up your radio you will be requested to select certain options. With the exception of your MMSI and ATIS ID, you will also be requested to enter these options after a factory reset.

After acknowledging the startup screen, unless previously set you will be prompted to make the following selections:

1. **Language selection** — See [5.8 Selecting a language](#) for available languages.
2. **Turn on AIS reception (Ray70 and Ray91 only)** — Enables the built-in AIS receiver. This step is only applicable to radios with a built-in AIS receiver. See [5.9 Switching on the AIS receiver](#) for more information.
3. **Select network type** — Selects which connection to transmit AIS and DSC information on, to connected equipment. This step is only applicable if the AIS receiver was turned on in the previous step. See [5.10 Selecting a network type](#) for available options.
4. **Enter MMSI number** — Required to enable DSC functions. This option is not required after a factory reset, or if the radio has been pre-programmed in MARCOM-C mode, or has ATIS enabled. See [5.11 Entering an MMSI number](#) for more information. If not already selected you will also be prompted to select your network type.
5. **Enter ATIS ID** — Required when the radio will be used in the inland waterways of Europe. This step is only applicable if the radio has been pre-programmed in MARCOM-C mode. See [5.12 Entering an ATIS ID](#) for more information.
6. **Frequency band selection** — Sets the relevant channels for your region. This step is not applicable if the radio has been pre-programmed in MARCOM-C mode. See [5.13 Changing the radio region](#) for more information.

5.8 Selecting a language

The language the radio uses can be changed.

From the Main menu:

1. Select **Set-up**.
2. Select **Language**.

The languages available are:

- **English (default)** — English
- **Español** — Spanish
- **Français** — French
- **Deutsch** — German
- **Italiano** — Italian

3. Select the language that you want the radio to be set to.

The User interface language is changed to the selected language.

5.9 Switching on the AIS receiver

If your radio includes a built-in AIS receiver then it can be enabled and disabled as follows:

From the Main menu:

1. Select **Set-up**.
2. Select **AIS**.
3. Select **On** to switch the receiver on, or select **Off** to switch the receiver off.

5.10 Selecting a network type

When connecting your radio to other devices it is important to ensure you select the network connection and type that you want data to be transmitted over.

From the Main menu:

1. Select **Set-up**.
2. Select **Network output**.

The following network types are available:

- NMEA 2000 (default)
- 0183 High speed
- 0183 Std speed

3. Select the network type relevant to the devices connected to your radio. If your radio is not connected to any other devices any option can be selected.

*Selecting **0183 Std speed** will disable the built-in AIS receiver, where applicable.*

The **Network output** setting determines the baud rate of the NMEA 0183 input:

Network output setting	NMEA 0183 input baud rate
NMEA 2000	Standard speed (4,800)
NMEA 0183 High Speed	High speed (38,400)
NMEA 0183 Standard Speed	Standard speed (4,800)

5.11 Entering your MMSI number

To program your radio with your MMSI number follow the steps below.

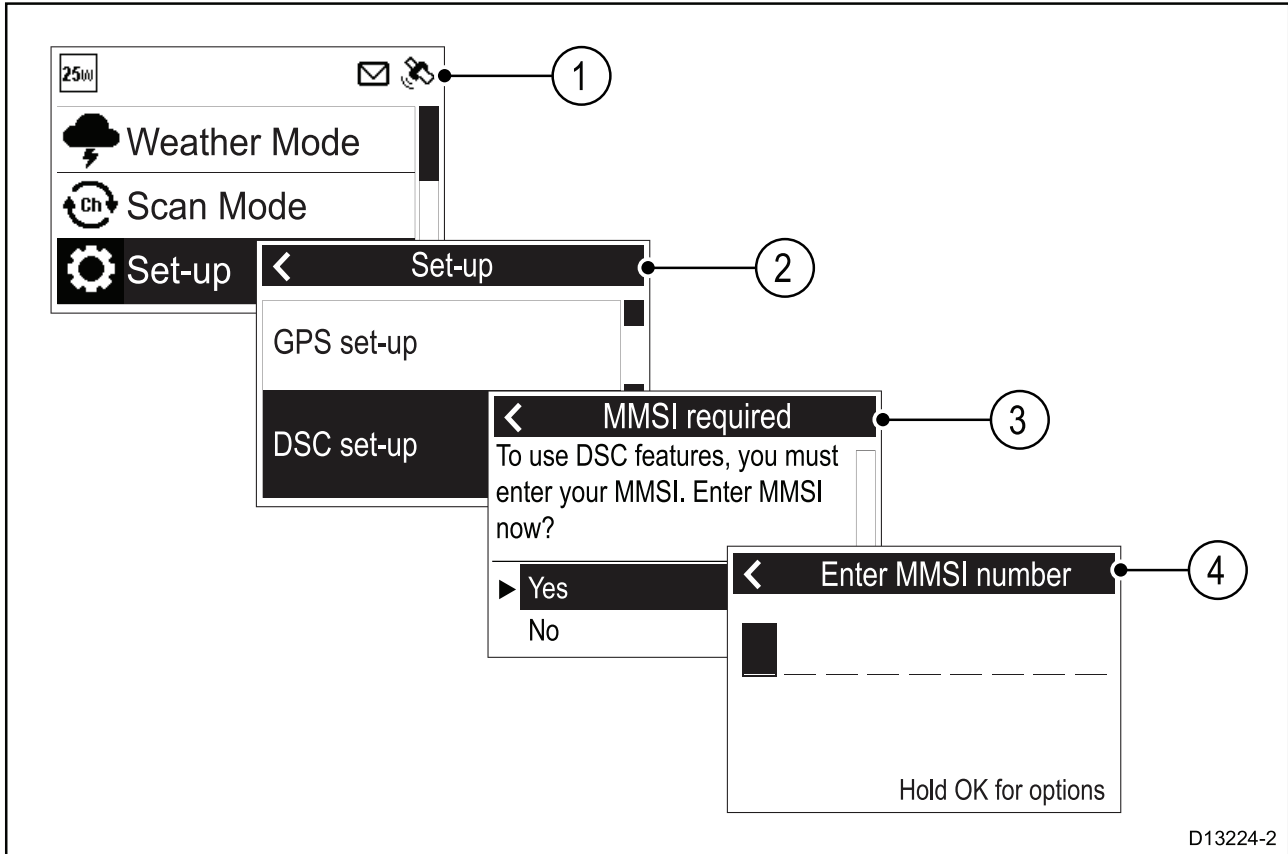

From the Set-up menu: (**Menu > Set-up**)

1. Select **DSC set-up**.
2. Select **MMSI**.

*The **MMSI required** message will be displayed if no MMSI number has been set.*

3. Select **Yes**.
4. Use the **Channel Up** and **Channel Down** buttons to cycle through the available numbers and press **OK** to confirm each number and move to the next digit.

Important:

You should only enter the unique 9 digit MMSI number provided by your licensing authority.

MMSI numbers starting with a '0' are only used for groups and coast stations. If you enter a '0' as the first digit the radio will assume you are entering a coast station MMSI and automatically assign a '0' as the second digit; this is to ensure a group MMSI is not entered as the radio's unique MMSI.

5. Press the **Back** button at any time to edit digits you have already entered.
6. Press and hold the **OK** button to display options to change the position of the cursor.

7. When the final digit is confirmed press **OK**.

Example

← Enter MMSI number

1 2 3 4 5 6 7 8 9

Done

8. The MMSI is displayed onscreen, check that it is correct, then:
- Select **Yes – Save**, or
 - if the number entered is not correct select **No – Retry**.

Caution: MMSI and ATIS ID entry

You can only enter the MMSI number and ATIS ID once!

If you store an incorrect MMSI number or ATIS ID in your product, it will have to be reset by an authorized **Raymarine**® dealer.

5.12 Entering your ATIS ID

A unique ATIS ID must be entered before ATIS mode can be enabled.

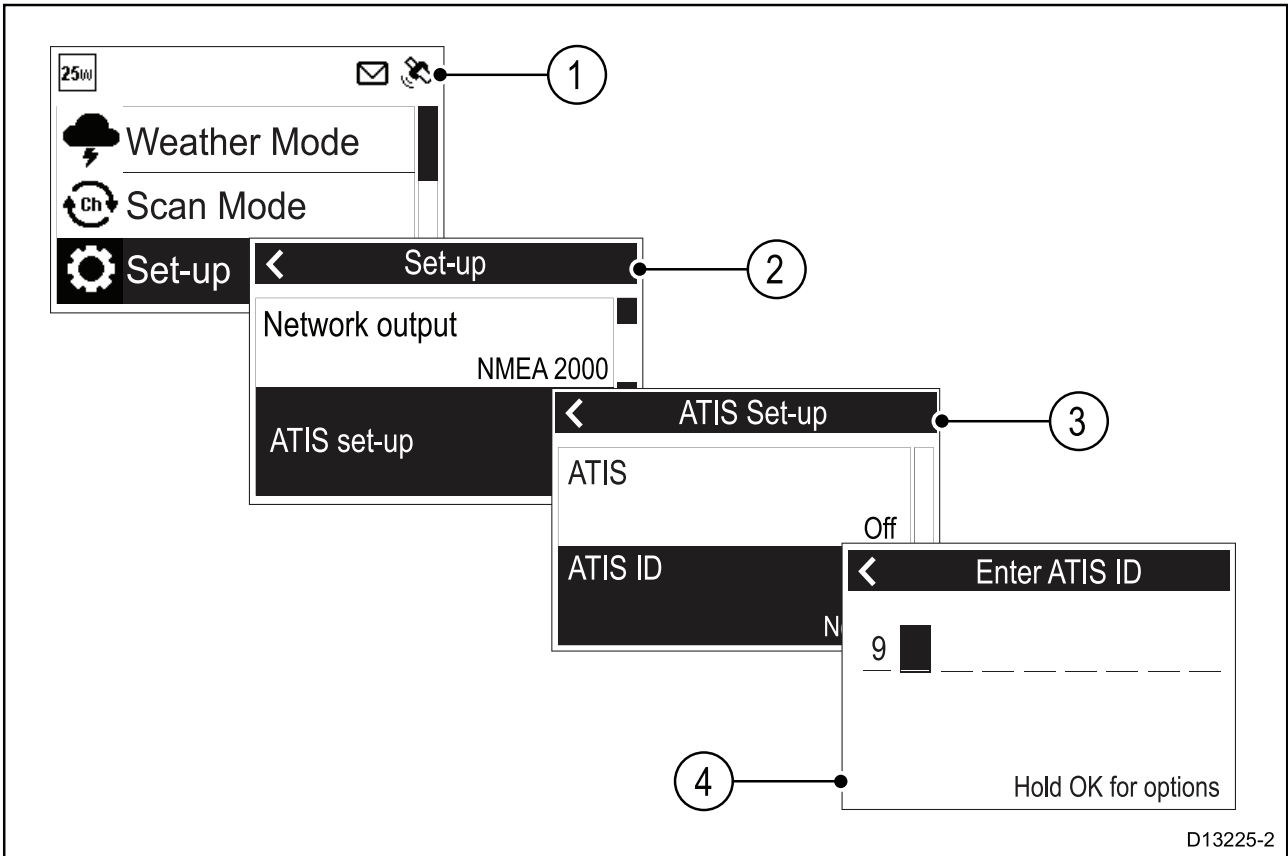

From the Main menu.

1. Select **Set-up**.
2. Select **ATIS set-up**.
3. Select **ATIS ID**.

***Not set** will be displayed if no ATIS ID has been set.*

The first digit is set to a '9' and cannot be changed, this is because all ATIS IDs start with a '9'.

As most ATIS IDs consist of a '9' followed by your 9 digit MMSI number; if your radio already has an MMSI number the ATIS ID will be pre-filled in this format.

4. If the ATIS ID has been pre-filled, check it carefully against your issued ATIS ID.
5. To enter your ATIS ID manually, use the **Channel Up** and **Channel Down** buttons to cycle through the available numbers and press **OK** to confirm each number and move to the next digit.

You should only enter the unique 10 digit ATIS ID provided by your licensing authority.

6. Press the **Back** button at any time to edit digits you have already entered.
7. Press and hold the **OK** button to display options to **Move cursor** back and forward through the digits.

8. When the final digit is confirmed press **OK**.

Example

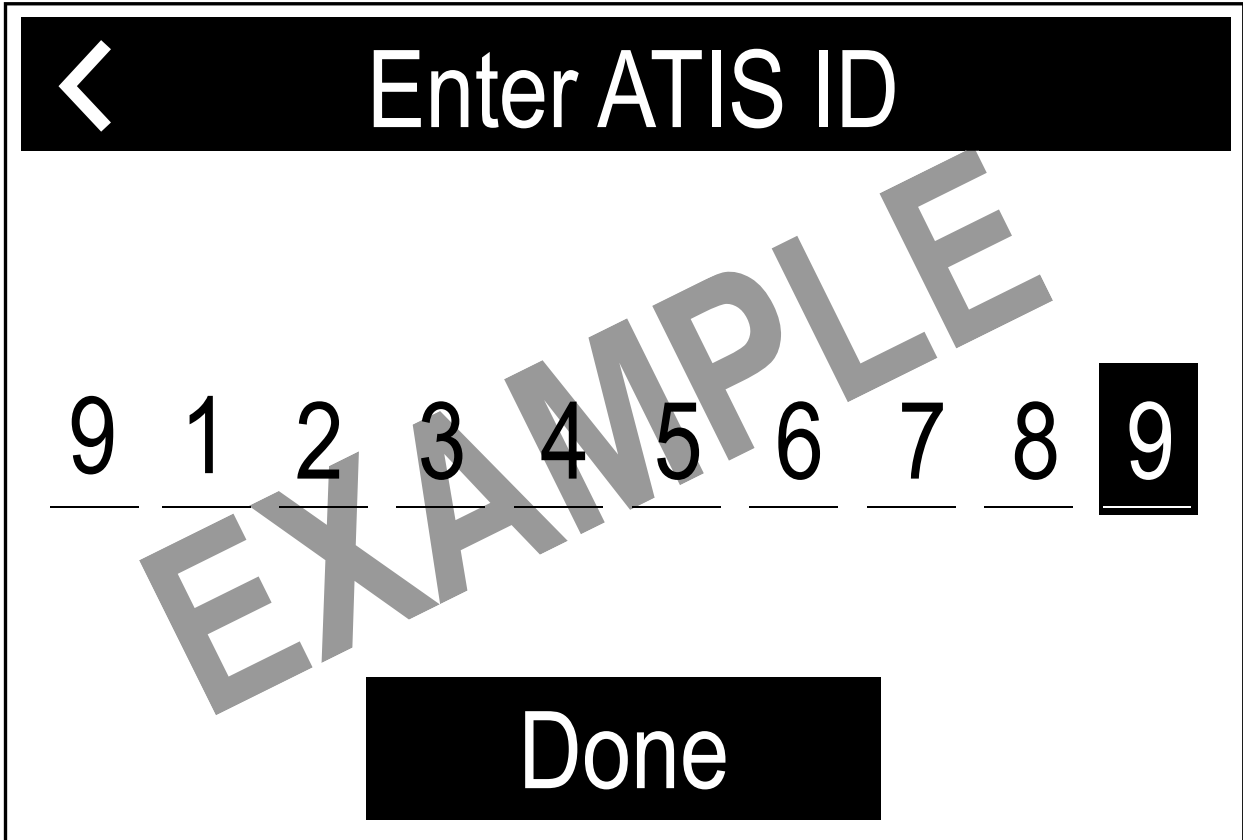

9. The ATIS ID is displayed onscreen, check that it is correct, then:

- i. Select **Yes – Save**, or
- ii. if the number entered is not correct select **No – Retry**.

Caution: MMSI and ATIS ID entry

You can only enter the MMSI number and ATIS ID once!

If you store an incorrect MMSI number or ATIS ID in your product, it will have to be reset by an authorized **Raymarine**® dealer.

Enabling and disabling ATIS mode

ATIS is a European system used on some inland waterways. A unique ATIS ID must be entered before ATIS mode can be enabled.

With ATIS mode enabled the radio's region will be fixed to the INT (international) frequency band and the following functions are disabled:

- DSC functions
- Watch Mode
- Scan Mode
- High/low power is restricted on certain channels

From the Main menu.

1. Select **Set-up**.
2. Select **ATIS set-up**.
3. Select **ATIS**.

If no ATIS ID has been set then you will be requested to enter one before ATIS mode is enabled.

4. If an ATIS ID has already been set then select **On** to enable ATIS mode or **Off** to disable ATIS mode.

5.13 Changing the radio region

Prior to using the radio you must set the Frequency band to the region your radio will be used in.

From the Main menu:

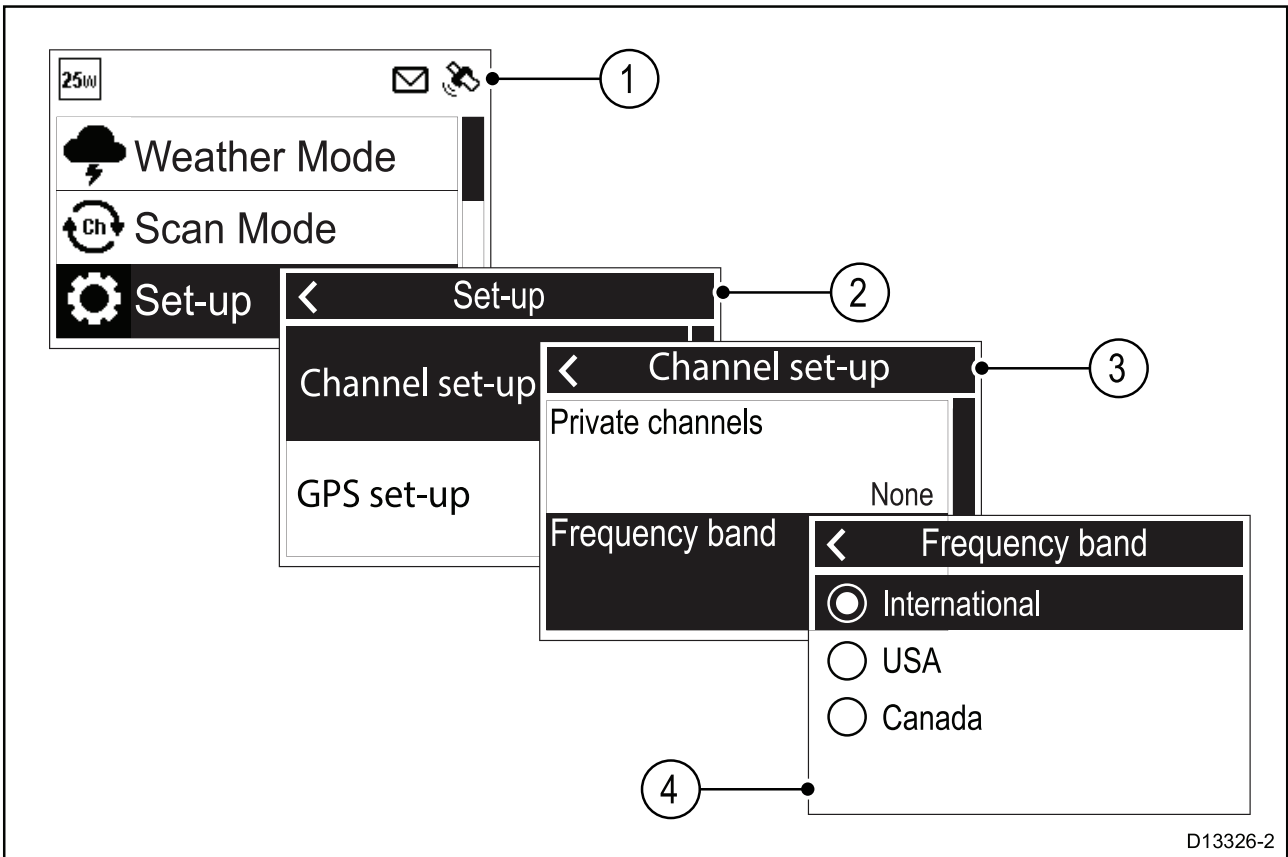

1. Select **Set-up**.
2. Select **Channel set-up**.
3. Select **Frequency band**.
4. Select the relevant region from the list.

The available options are:

- **International**
- **USA**
- **Canada**

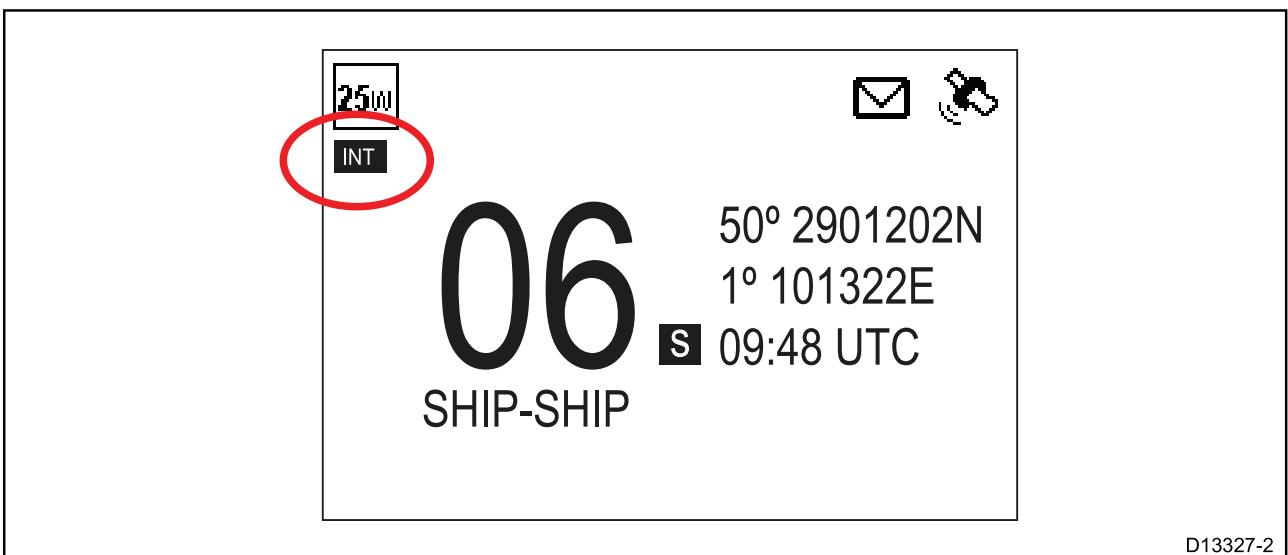

An icon is displayed on the Homescreen that identifies which region has been set.

5.14 Switching between high and low transmit power

You can switch transmit power using the HI/LO button on the Handset / Fismic.

The transmit power can also be changed from the **Set-up** menu: **Menu > Set-up**

1. Select **Power output**.

Selecting the Power output option will switch between High (25 watt) and Low (1 watt) power output.

5.15 GNSS (GPS) set up

If your radio has a GNSS (GPS) position fix then the following information can be displayed:

- latitude
- longitude
- UTC time
- COG and SOG

When position data is available the satellite icon is displayed onscreen.

If no position data is available then the latitude, longitude and time can be entered manually so that it can be included in DSC distress transmissions.

Position data received from other vessels can be displayed on a connected Raymarine® multifunction display.

Enabling and disabling the internal GNSS (GPS)

From the **GPS set-up** menu: **Menu > Set-up > GPS set-up**

1. Select **Integrated GPS**.

Selecting **Integrated GPS** will switch the radio's internal GNSS receiver On and Off.

GNSS data source

Your radio includes a built-in GNSS (GPS) receiver that can be used to obtain position data. Your radio can also use position data from a GNSS (GPS) receiver connected to the same SeaTalkng® or NMEA 2000 network.

If your radio's internal receiver cannot obtain a position fix or if your radio's internal receiver is switched off then a network data source for shall be used instead, if available.

No position data

If no position data is available or position data becomes unavailable; after 10 minutes an audible warning is sounded, the GNSS (GPS) icon flashes and the **No position data** message is displayed.

Once the warning has been acknowledged the GNSS (GPS) icon will continue to flash. The **No position data** warning is repeated every 4 hours if position data is still unavailable, has not been entered manually or has been entered manually but over 23.5 hours ago.

If position data has been entered manually the display alternates between displaying the manual position and time and the **Manual Position** message. If the manually entered position has not been updated in the last 4 hours the GNSS (GPS) icon flashes and an audible warning is sounded. This warning will be repeated every 4 hours until position is manually updated or position data becomes available.

Where no position data is available or has not been manually updated for 23.5 hours then position data will change to '9's and time will change to '8's.

Entering position manually

If GNSS (GPS) position data is not available it can be entered manually.

Select **Set manual position** from the **GPS set-up** menu: **Menu > Set-up > GPS set-up > Set manual position**.

1. Use the **Channel Up** and **Channel Down** buttons to cycle through the available numbers and press **OK** to confirm each number and move to the next digit.
2. When the relevant information has been entered select **OK** to confirm the details.

Selecting (GNSS) GPS information to display

You can change the GNSS (GPS) data that is displayed on the Homescreen.

From the **GPS set-up** menu: **Menu > Set-up > GPS set-up**.

1. Select **Homescreen display**.

Selecting Homescreen display will switch between **Location & time** and **Location & COG/SOG**.

The **Homescreen display** option is also available from the **Display set-up** menu: **Set-up > Display set-up > Homescreen display**.

Setting time format and offset

You can change the Format and Offset that is applied to the time displayed onscreen.

From the **Units** menu: **Menu > Set-up > Units**.

1. Select **Time format**.
2. Select the desired format:
 - 12 hour
 - 24 Hour (default)
3. Select **Time offset**.
4. Adjust the offset to the desired value using the **Channel Up** and **Channel Down** buttons.
5. Select **OK** to confirm the selection.

Chapter 6: Wireless handset stations

Chapter contents

- [6.1 Wireless handsets on page 104](#)
- [6.2 Connecting a wireless handset to the hub on page 106](#)
- [6.3 Connecting the wireless speaker to the Wireless handset on page 108](#)
- [6.4 Wireless set-up menu options on page 109](#)

6.1 Wireless handsets

Wireless handsets are compatible with the Ray90 and Ray91 VHF DSC radios. Using the optional accessories you can create up to 3 fully functional wireless handset stations.

As a minimum the Wireless hub and Wireless handset accessories are required to create a wireless handset station. Additionally a Wireless speaker can be connected to each Wireless handset.

After connecting your Wireless hub to your Ray90 / Ray91 Base station, the process for setting up a wireless handset station should be:

1. Fully charge the Wireless handset.
2. Connect the Wireless handset to the Wireless hub.
3. If required, connect a Wireless speaker to the Wireless handset.



Warning: Retain a wired handset station

A wired handset station should always be connected and available.

Wireless handset charging

When inserted into the wireless handset charging holster the wireless handset will be charged using inductive charging.

Attention

Ensure your wireless handset is fully charged before use.

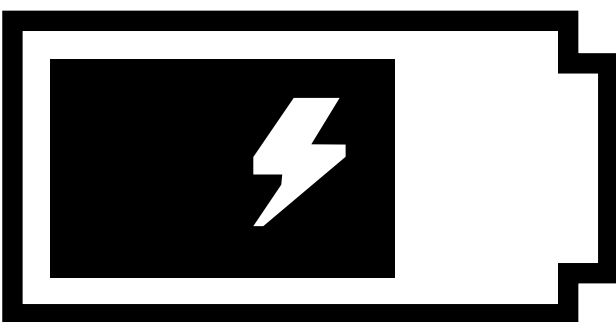
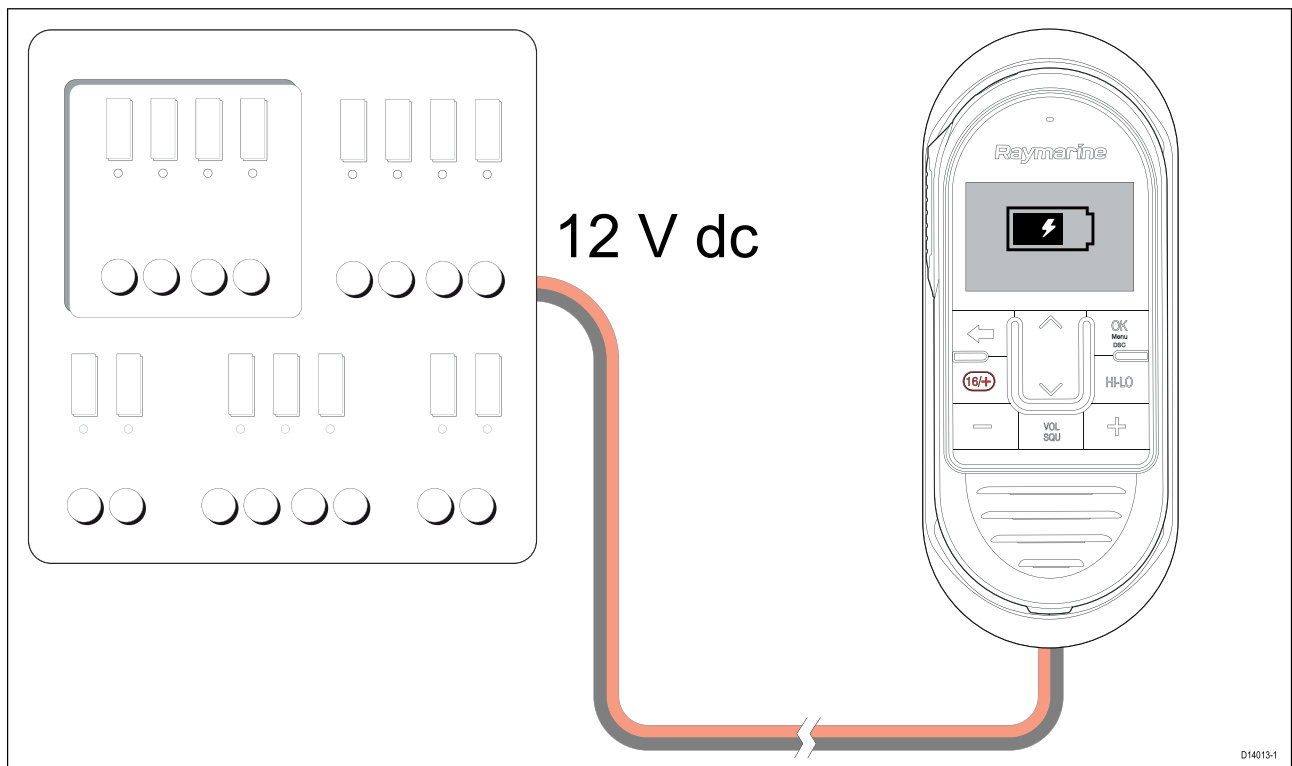

Charging

Whilst charging a battery symbol will gradually fill up.

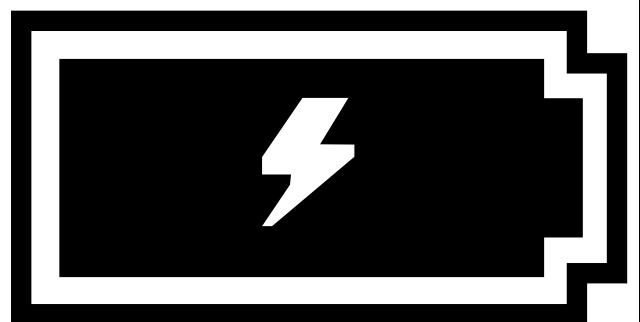

Charged

When fully charged the battery symbol will be full.

With the Handset powered on the battery symbol will be displayed in the status bar at the top of the screen.

With the handset powered off the battery symbol is displayed fullscreen.

6.2 Connecting a wireless handset to the hub

Wireless handsets must be connected to the Ray90 / Ray91 via a Wireless hub.

When the Wireless handset is powered on for the first time you will need to connect it to a Wireless hub.

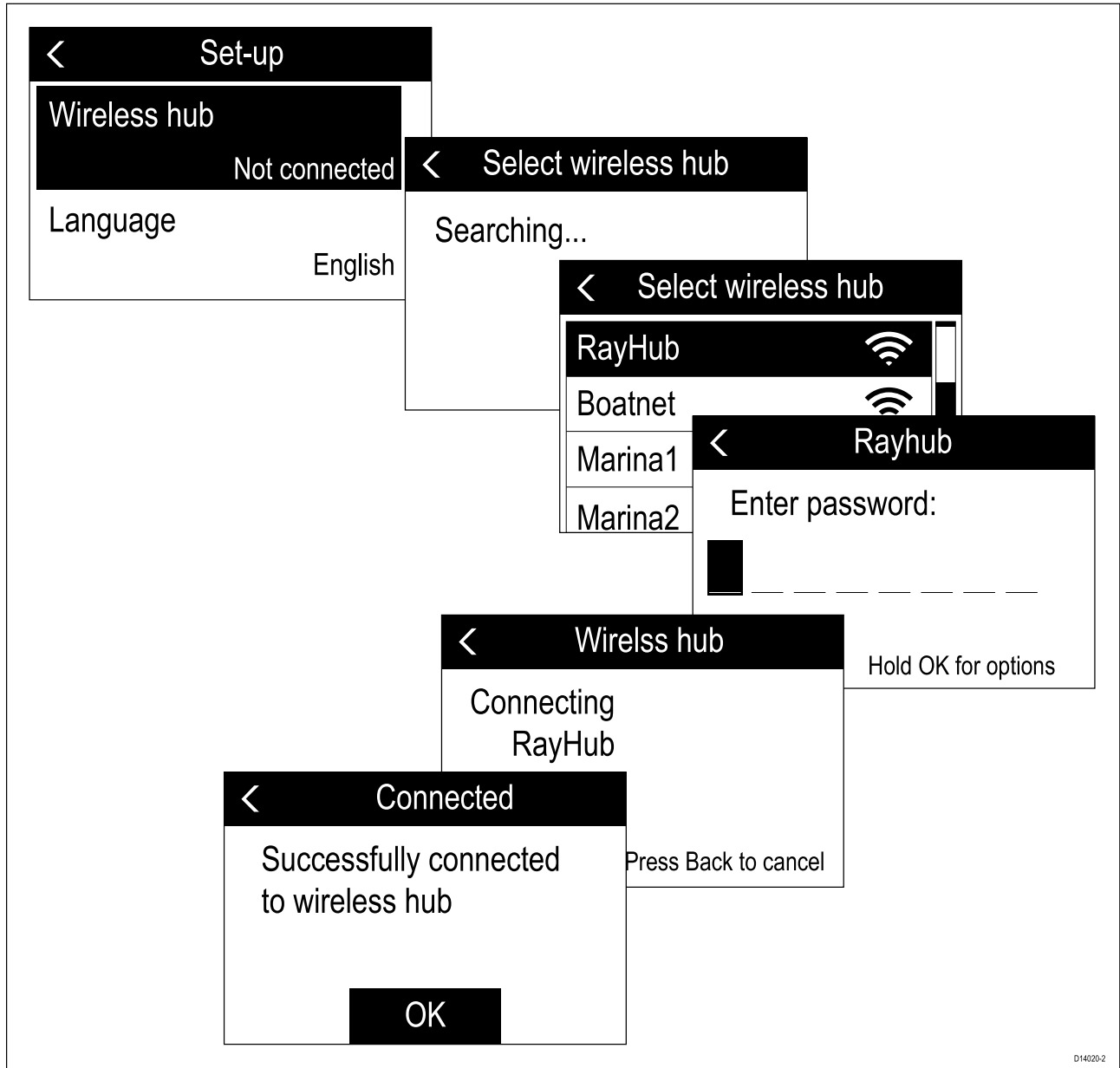

1. Select **Wireless hub**.
The handset will display a list of wireless devices in range.
2. Select your Wireless hub from the list.
3. Enter the password.

Important:

- The Wireless hub's default password is a '0' followed by the serial number of the **Base station** the Wireless hub is connected to (e.g.: "0" & "1170002" = "01170002"). Your Base station's serial number consists of 7 digits and can be found on the product box, product label or on the spare serial number labels supplied in the box.
- You can check the Wireless hub's password using a Wired handset by selecting: **Menu > Set-up > Wireless set-up > Wireless hub set-up > Password**.

The handset will now connect to the Wireless hub.

4. Select **OK**.

Checking the Wireless hub's password

You can check the Wireless hub's password at anytime using a Wired handset.

1. Select **Menu**.
2. Select **Set-up**.
3. Select **Wireless set-up**.
4. Select **Wireless hub set-up**.
5. Select **Password**.

The current password is displayed.

Changing your wireless hub's password

If desired you can change the Wireless hub's default password.

Using a wired handset:

1. Select **Wireless hub set-up** from the **Wireless set-up** menu: (**Menu > Set-up > Wireless set-up > Wireless hub set-up**).
2. Select **Password**.
3. Use the **Channel Up**, **Channel Down** and **OK** buttons to change the default password.

The password can use up to 8 characters. For the most secure password use a variety of upper and lower case letters, numbers and symbols.

4. When finished, select **OK** to confirm.
5. Re-connect your Wireless handset to the hub following the [6.2 Connecting a wireless handset to the hub](#) procedure.

Note:

- Whilst the password change is being applied the **Wireless set-up** menu will be unavailable.
- Ensure you make a note of your Hub's new password.

Changing the hub's wireless channel

If you experience interference with your wireless handset station then you can change the wireless channel used by the hub to a channel that is less congested with Wireless signals.

You must use a Wired handset to change the Hub's wireless credentials.

1. Select **Wireless hub set-up** from the **Wireless set-up** menu: (**Menu > Set-up > Wireless set-up > Wireless hub set-up**).
2. Select **Wireless channel**.
3. Select a wireless channel.

Channels 1 to 13 are available, use a wireless network analyzer to find the least congested channel. The preferred wireless channels are 1, 6 and 11 as these overlap with the fewest other wireless channels, however if these channels are congested then try others.

Note:

- Whilst the channel change is being applied the **Wireless set-up** menu will be unavailable.
- Your Wireless handset will automatically reconnect to the hub using the new channel.

6.3 Connecting the wireless speaker to the Wireless handset

You can connect a Wireless speaker to your Wireless handset.

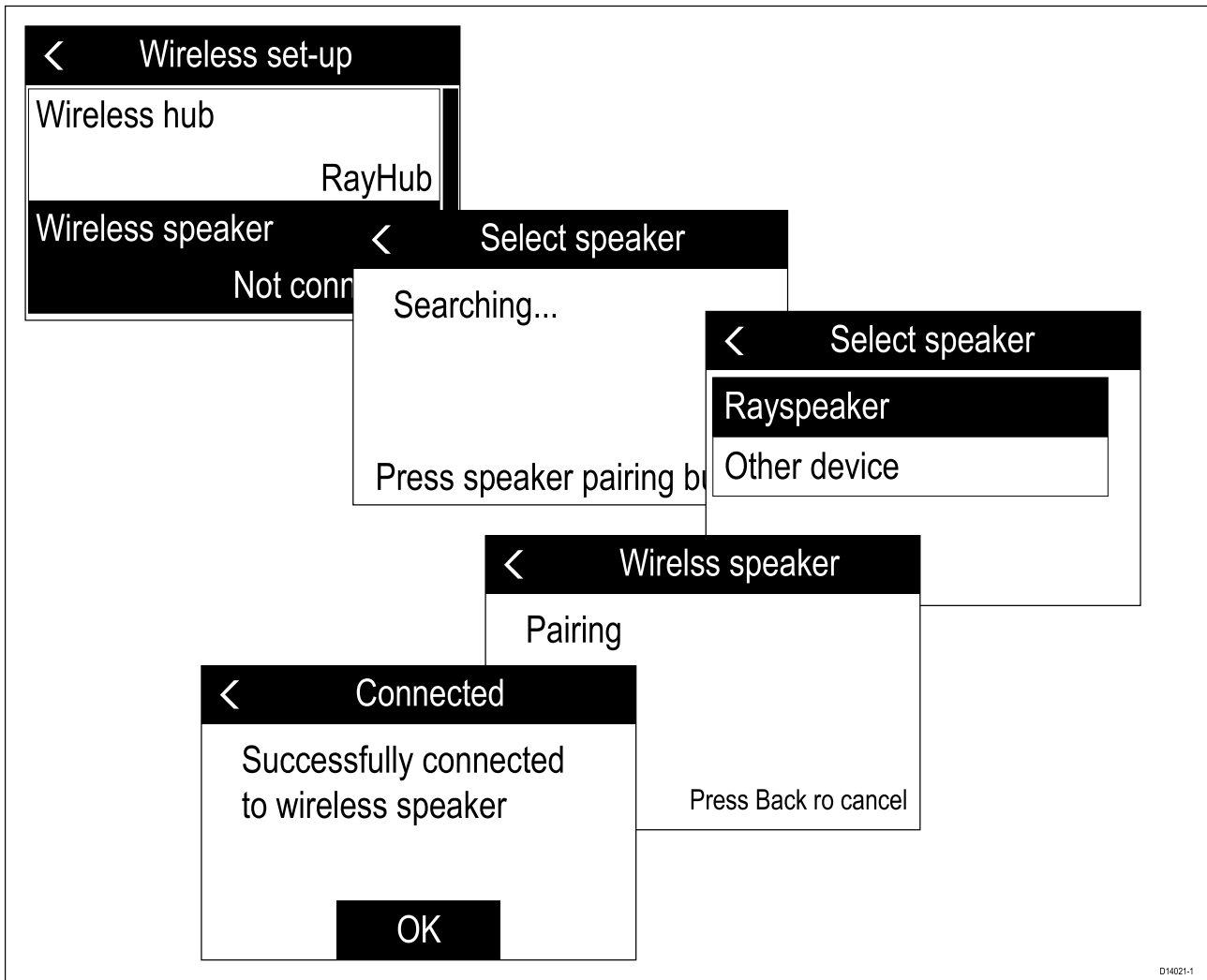

1. Power on the Wireless speaker.
2. Press the **Pairing** button on the front of your Wireless speaker to pair with a Wireless handset for the first time.
3. Using the Wireless handset, select **Wireless speaker** from the **Wireless set-up** menu: **Menu > Maintenance > Wireless set-up**
The handset will search for available devices.
4. Select your Wireless speaker from the list.
The Wireless handset will now pair with the Wireless speaker.
5. Select **OK**.

The Wireless handset's audio will now be heard through the Wireless speaker.

Note:

- You can only output audio to 1 speaker from the same handset.
- If the pairing is unsuccessful, power the wireless speaker off and then back on again and repeat the process.

Disconnecting a Wireless speaker

To disconnect your Wireless speaker from the Wireless handset follow the steps below:

With the speaker connected to the handset:

1. Press the **Pairing** button on the front of the speaker.
2. Once disconnected the speaker can be connected to any Wireless handset by following the [6.3 Connecting a wireless speaker to the wireless handset](#) procedure.

6.4 Wireless set-up menu options

The Wireless set-up menu is available when a Wireless hub is connected.

Menu item	Description	Options
Wireless hub	Enables you to search for and connect to a Wireless hub.	List of available networks.
Wireless hub set-up	Provides access to the Wireless hub's settings.	<ul style="list-style-type: none"> • Wireless hub name • Password • Wireless channel
Wireless speaker	Enables you to search for and connect to a Wireless speaker.	Search for devices.

Wireless hub set-up menu options

Menu item	Description	Options
Hub name	The default name is RayHub. You can change the hub name to any alphanumeric (including standard symbols) name using up to 10 characters.	Edit hub name
Password	The Wireless hub's default password is a '0' followed by the serial number of the Base station the Wireless hub is connected to (e.g.: "0" & "1170002" = "01170002"). Your Base station's serial number consists of 7 digits and can be found on the product box, product label or on the spare serial number labels supplied in the box.. You can change the password to any alphanumeric (including standard symbols) password using up to 8 characters.	Change password
Wireless channel	Enables you to change the 2.4Ghz channel used by the Wireless hub.	Channels 1 to 13

Wireless handset not connected menu

When a connection to a Wireless hub is not available or connection is cancelled, the following menu options will be displayed on the Handset.

Menu item	Description	Options
Wireless hub	Enables you to search for and connect to a Wireless hub.	List of available networks.
Language	Enables selection of the user interface language.	<ul style="list-style-type: none"> • English — English • Español — Spanish • Français — French • Deutsch — German • Italiano — Italian
Backlight	Provides access to the Backlight level	<ul style="list-style-type: none"> • 1 to 9 • Off

Menu item	Description	Options
Contrast	Provides access to the Contrast level	<ul style="list-style-type: none">• 1 to 10
Key beep	Enables adjustment of the audible beep when pressing buttons.	<ul style="list-style-type: none">• Off• Quiet (default)• Loud

Chapter 7: Digital selective calling (DSC)

Chapter contents

- 7.1 Digital Selective Calling (DSC) on page 112
- 7.2 Distress calls on page 114
- 7.3 Urgency calls on page 120
- 7.4 Safety calls on page 121
- 7.5 Individual (routine) calls on page 122
- 7.6 Group calls on page 123
- 7.7 Position requests on page 124
- 7.8 Phonebook on page 125
- 7.9 Call logs on page 126
- 7.10 Test calls on page 127
- 7.11 DSC set-up menu options on page 128

7.1 Digital Selective Calling (DSC)

Traditional VHF radio systems require users to listen until someone speaks, and then determine whether the call is for them. DSC ensures that calls are received by alerting or announcing the intended recipient(s) first so they are ready to listen to the subsequent message on the relevant channel.

DSC is part of the Global Maritime Distress and Safety System (GMDSS), a maritime communications system for emergency and distress messages and all types of routine communications such as ship-to-ship or ship-to-shore.

DSC is a digital signalling system, which operates on VHF channel 70. DSC calls include other data such as your vessel's identification number, purpose of the call, your position and the channel you want to speak on.

DSC calls can be divided into 4 categories and are prioritized as shown below:

1. Distress
2. Urgency
3. Safety
4. Routine

Distress

A Distress call should only be used when there is imminent danger to a vehicle or person that requires immediate assistance.

When making a distress call the following information is transmitted to all stations within range:

- Vessel MMSI number.
- Vessel position (must be input manually if no position data is available).
- Local time (must be input manually if no position data is available).
- Nature of the distress (when designated).
- Transmission frequency.

The call is automatically repeated at approximately 4 minute intervals until it is acknowledged either by a coast radio station (CRS) or a vessel within radio range. Distress calls must be followed by a MAYDAY call on priority channel 16.

Urgency

An urgency call should be used when there is danger to a vehicle or person that does not require immediate assistance.

When making an urgency call the following information is transmitted to all stations within range:

- Vessel MMSI number.
- Vessel position (must be input manually if no position data is available).
- Local time (must be input manually if no position data is available).
- Transmission frequency.

Once an urgency call is sent it must be followed with a PAN PAN voice message on channel 16 and include the necessary details.

Safety

A safety call should be used when there is an important navigational warning or meteorological forecast/broadcast. Safety alerts can also be used for communications during search and rescue operations.

When making a safety call the following information is transmitted to all stations within range:

- Vessel MMSI number.
- Vessel position (must be input manually if no position data is available).
- Local time (must be input manually if no position data is available).
- Transmission frequency.

Once a safety call is sent it must be followed with a SECURITE voice message on channel 16 and include the necessary details.

Individual (routine)

Routine calls are used for contacting other vessels, marinas, or shore stations.

Routine calls are made on channel 70 using the dedicated Maritime Mobile Service Identity (MMSI) number of the station to be contacted, selecting a VHF working channel and sending the call. Both radios automatically switch to the chosen channel for conversation.

Routine calls can also be made to groups — When groups of ships need the same information (yacht races, club rallies etc.) a special group-call identity can be used to enable restricted broadcast calls.

Note:

To transmit precise position data, the radio must be connected to a GNSS (GPS) receiver. Otherwise, regular manual position updating is required.

7.2 Distress calls

Making a designated distress call

When making a Distress call you can specify the nature of the distress, if GNSS (GPS) data is not available you must also specify your coordinates.

Note:

Your radio must have an MMSI number saved before DSC functions can be used.

From the Distress call menu: **Menu > DSC Calls > Distress call**

1. Select a distress type from the list.
 - If your radio is receiving a valid GNSS (GPS) position then the distress type and coordinates are displayed on-screen, otherwise you will be prompted to enter your position coordinates manually.
2. If prompted, enter your position coordinates and local time using the **Channel Up** and **Channel Down** buttons to enter the relevant details.
3. When complete press the **OK** button.
4. Follow the steps for 'Making a Distress Call' to transmit the distress.

Making a Distress call

In an emergency you can make an automatic DSC distress call.

The **DISTRESS** button is located on the rear of the handset.

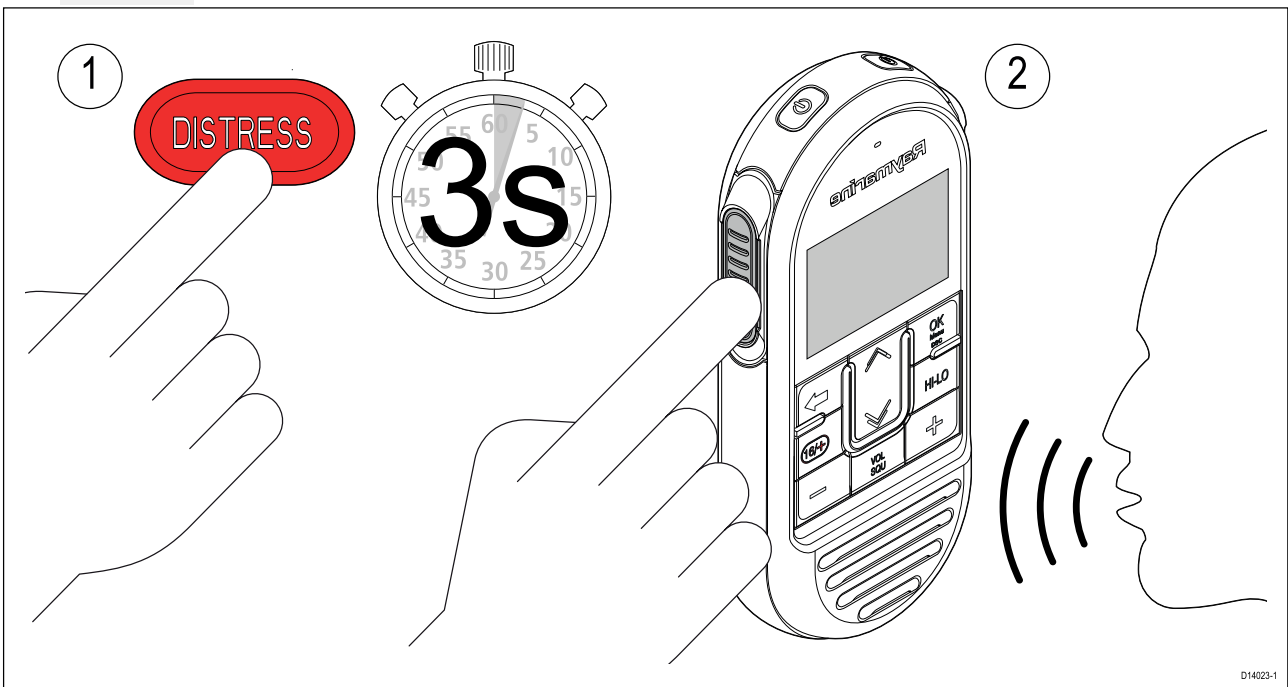

1. Open the **DISTRESS** button's cover and then press and hold the **DISTRESS** button for 3 seconds.

Once the button is pressed a 3 second count down will begin, when the count down reaches zero the DSC distress call is transmitted.

The Distress call is repeated automatically until it is acknowledged.

2. Press and hold the **PTT** button, then slowly and clearly speak the details of the distress in the following format:

MAYDAY, MAYDAY, MAYDAY

This is — state name of vessel 3 times

MAYDAY — state name of vessel 1 time

My position is — state latitude and longitude, or true bearing and distance from a known point

I am — state nature of distress e.g. sinking, on fire etc.

I have — state number of persons on board and any other information — drifting, flares fired etc.

I REQUIRE IMMEDIATE ASSISTANCE

OVER

3. Release the **PTT** button.

Making a Mayday call

In an emergency you can also make a Mayday call following the instructions below.

1. Press the **16 PLUS** button.
2. Press and hold the **PTT** button.
3. Slowly and clearly speak the details of the distress:

MAYDAY, MAYDAY, MAYDAY

This is — state name of vessel 3 times

MAYDAY — state name of vessel 1 time

My position is — state latitude and longitude, or true bearing and distance from a known point

I am — state nature of distress e.g. sinking, on fire etc.

I have — state number of persons on board and any other information — drifting, flares fired etc.

I REQUIRE IMMEDIATE ASSISTANCE

OVER

4. Release the **PTT** button.
5. If an acknowledgement is not received then repeat steps 2 to 4 above.

Cancelling a distress call before transmission

To cancel a distress call before it is transmitted follow the steps below:

1. Release the **DISTRESS** button before the countdown timer completes.
When the button is released you will be returned to normal operation.

Canceling a distress call after transmission

A distress call can be cancelled after it has been transmitted.

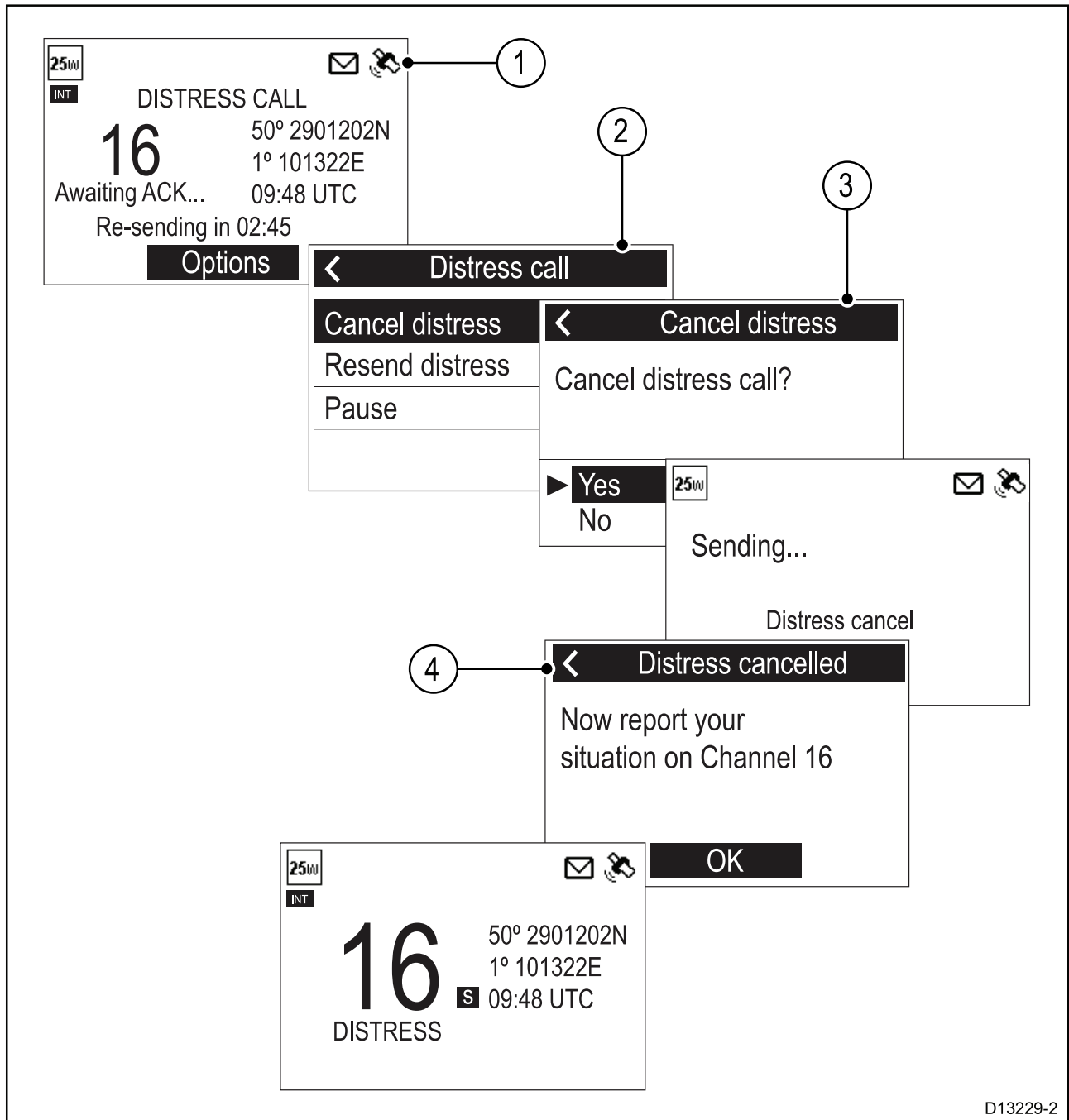

D13229-2

1. Select **Options**.
2. Select **Cancel distress**.
3. Select **Yes** to confirm cancellation.
4. Select **OK**.
5. Press and hold the **PTT** button and make a broadcast to all stations giving your vessel's name, call sign and MMSI number and cancel the false distress alert

Example: "All, Stations, All Stations, All Stations. This is: NAME, CALL SIGN, MMSI ID, POSITION.
Cancel my distress alert of: DATE, TIME, NAME, CALL SIGN"

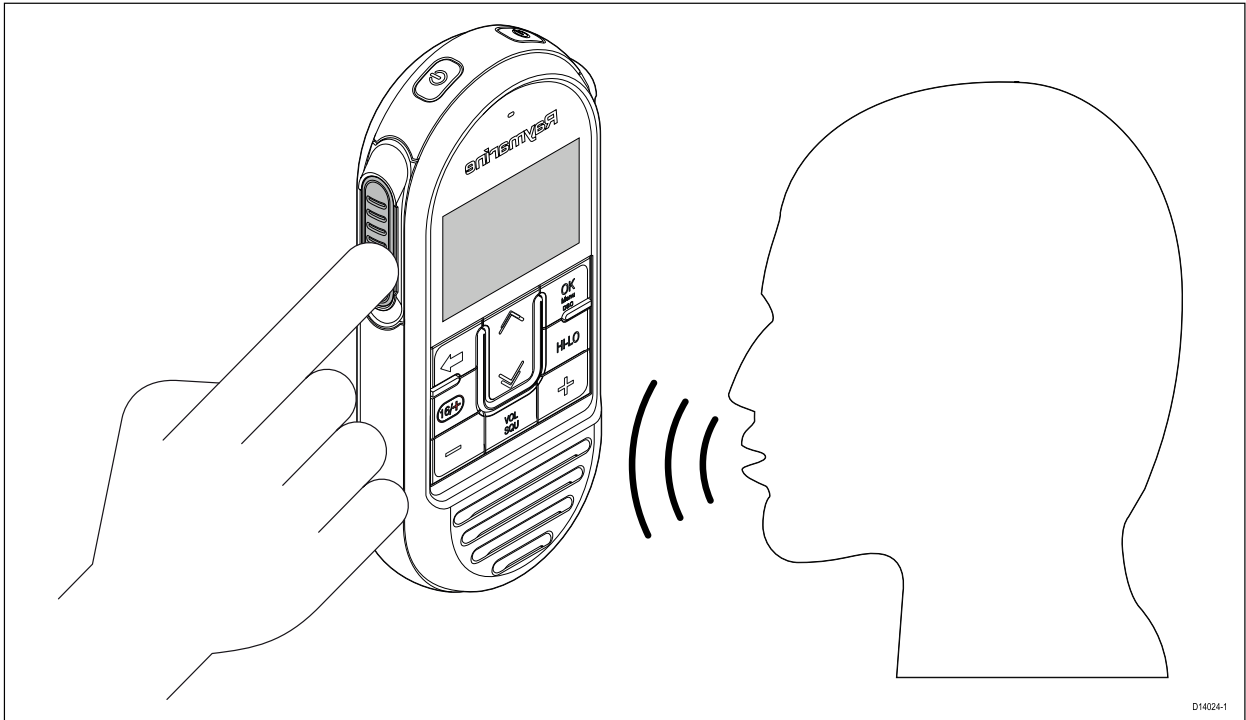

6. Repeat the broadcast described in step 5.

Receiving a distress call

It is expected that only a Coast Radio Station (CRS) will acknowledge DSC distress calls and will act as the coordinator for the rescue operation.

When a distress call is received an alarm is sounded at full volume and the LCD displays information relating to the distress.

25W

SAT

DISTRESS CALL 00:04

Sinking

MMSI 123456789

▶ **Accept - Ch16 [10]**

Show info

Battery level indicator

If the **Auto channel change** function is enabled; 10 seconds after receipt of a distress call the radio will automatically re-tune to channel 16. Otherwise the user is prompted to change channel manually. The details of the distress call are recorded in the distress log and the envelope icon will flash to let you know a message has been received. When connected to a **Raymarine**® multifunction display (**MFD**) the position data from the distress call can also be displayed in the Chart application. When the received distress call is acknowledged by the CRS or by another station the radio will resume normal operation.

Ignoring a distress call

You can ignore a distress call by muting the alarm and cancelling the distress call screen.

If your radio is already tuned to the priority channel then the **Ignore** option will not be available.

With an incoming distress call displayed.

1. Select **Ignore** from the options displayed.
Normal operation is resumed.

Acknowledging a distress call

Distress calls must only be acknowledged if the call continues without acknowledgement from a CRS, you are close enough to the distressed vessel to be of assistance and are prepared to relay the distress to a CRS by any means possible. Class D DSC radios are forbidden from automatically acknowledging distress calls. Acknowledgement must only be made by voice message on channel 16.

After receiving a distress call that has gone unanswered:

1. Switch to channel 16 to listen for the distress voice message.
2. Wait for the CRS to acknowledge the call.
3. If the distress call is not acknowledged by another station then acknowledge the call as follows:

MAYDAY

(MMSI of the vessel in distress)

Name of vessel in distress <repeated 3 times>

Call sign of the vessel in distress

This is <MMSI of your vessel>, <name of your vessel repeated 3 times> <call sign of your vessel>

RECEIVED MAYDAY

4. You **MUST** then notify the shore authorities by any means possible to relay the distress call.

Manually relaying a distress call

A distress relay should only be sent if: the person or vehicle in distress is unable to transmit the distress call itself, for example red flares sighted at night or the person or vehicle in distress is out of range of a CRS and you have already acknowledged the distress by voice message. You can also relay a received distress relay alert manually if it goes unanswered.

1. Switch to channel 16
2. Slowly and clearly speak the details of the distress:

MAYDAY RELAY, MAYDAY RELAY, MAYDAY RELAY

This is <MMSI of your vessel, name of your vessel repeated 3 times and your call sign>

Received the following MAYDAY from <MMSI of vessel in distress, name of vessel in distress, call sign of vessel in distress>

Message begins

Message received from vessel in distress or details of the distress

Message ends

OVER

Distress relays sent by other stations

When a Coast Station or another vessel, has received, and acknowledged a DSC distress alert it may transmit a distress alert relay to other vessels in the immediate area.

Distress relays sent from other stations can be received by the radio.

The radio cannot re-send a distress relay automatically. If required you can relay a distress relay message manually.

If a distress relay is sent specifically to the radio then it can be acknowledged, otherwise acknowledgement is not required.

Acknowledging a distress relay sent to your vessel

If a distress relay is specifically sent to your vessel this will be because the sender deems you to be in a position to assist in the rescue. The distress relay information is displayed onscreen.

When a distress relay is received:

1. Select **Show info** from the options to review the relevant details.
2. If the distress relay was sent individually to you, select **Accept** to send a distress relay acknowledgement.
3. Ensure the radio is tuned to channel 16.

Note: Distress relay calls can only be acknowledged automatically when sent individually to you.

7.3 Urgency calls

Making an urgency call

An urgency call should be used when there is danger to a vehicle or person that does not require immediate assistance. Urgency calls are transmitted to all stations.

From the **All ships call** menu: **Menu > DSC Calls > All ships call**.

1. Select **Urgency**.
2. Select the channel for subsequent communication.
The call is transmitted. Once the call has been successfully transmitted '**Sent**' is displayed onscreen and the channel is changed to the specified channel.
3. Press the **OK** button.
4. Press and hold the **PTT** button and speak the following message:

PAN PAN, PAN PAN, PAN PAN

ALL STATIONS, ALL STATIONS, ALL STATIONS

This is — MMSI of your vessel, name of your vessel repeated 3 times, call sign of your vessel.

Position — Your vessel's position.

Reason for call — State the reason for the call and include all information which will assist in the rescue.

OVER

Receiving an urgency call

When an urgency call is received:

1. Select **Show info** from the options to review relevant call details.
2. Select **Accept** at any time to accept the call.

If auto channel change is turned on then the channel will automatically change after 10 seconds.

The radio is re-tuned to the specified channel.

3. Listen for the urgency call message.

7.4 Safety calls

Making a safety call

Safety calls should be used when there is an important navigational warning or meteorological forecast/broadcast. Safety alerts can also be used for communications during search and rescue operations.

From the **All ships call** menu: **Menu > DSC Calls > All ships call**.

1. Select **Safety**.
2. Select the channel for subsequent communication.
The call is transmitted. Once the call has been successfully transmitted '**Sent**' is displayed onscreen and the channel is changed to the specified channel.
3. Press the **OK** button.
4. Press and hold the **PTT** button and speak the following message:

SECURITE, SECURITE, SECURITE

ALL STATIONS, ALL STATIONS, ALL STATIONS

This is — MMSI of your vessel, name of your vessel repeated 3 times, call sign of your vessel.

Position — Your vessel's position.

Reason for call — state the reason for the safety call.

OUT

Receiving a safety call

When a safety call is received:

1. Select **Show info** from the options to review relevant call details.
2. Select **Accept** at any time to accept the call.

If auto channel change is turned on then the channel will automatically change after 10 seconds.

The radio is re-tuned to the specified channel.

3. Listen for the safety call message.

7.5 Individual (routine) calls

Individual calls can be made to contacts saved in your Phonebook or to any station by manually entering an MMSI number.

Note:

When calling a coast station there is no need to select a channel for communication.

If a call cannot be accepted then a reason code is displayed.

No Reason	No reason given
Congestion	Congestion at maritime switching centre
Busy	Station Busy
Queue	Queue indication
Barred	Station barred
No operator	No operator available
Unavailable	Operator temporarily unavailable
Disable	Equipment disabled
Unable Ch	Unable to use proposed channel
Unable mode	Unable to use proposed mode

Making an Individual call

From the **Individual Call** menu: **Menu > DSC Calls > Individual Call**.

1. Select **Phonebook** to make a routine call to a contact saved in your Phonebook, or
2. Select **Recent Calls** to make a routine call to a contact that you have called recently, or
3. Select **Enter MMSI** to manually enter the MMSI number of the station you want to contact.
4. Select a contact or enter an MMSI manually and press the **OK** button.
5. Select the Channel you want to transmit the call on.

If the MMSI is a CSR then the radio will automatically tune to the correct Channel. The radio will wait for an acknowledgement to be received.

6. If an acknowledgement is received, press the **OK** button.
7. Press and hold the **PTT** button and speak your message.
8. Release the **PTT** button when you have completed your message.

Receiving an Individual call

With an incoming individual call displayed:

1. Select **Show info** from the options to review relevant call details.
2. Select **Reply on Ch ##** at any time to accept the call.

If auto channel change is turned on then the channel will automatically change after 10 seconds.

The radio is re-tuned to the specified channel.

3. To reject the call, select **Reject**.
4. If you rejected the call, select a reason for the rejection from the list.

Confirmation of the acceptance or rejection of the call is displayed. If you have accepted the call then the radio will re-tune to the requested channel.

7.6 Group calls

Group calls can be made to groups of vessels sharing the same Group MMSI numbers.

Group calls are made by selecting a saved group contact from the **Phonebook** or by entering the Group MMSI number for the group you want to call.

Making a group call

From the **Group Call** menu: **Menu > DSC Calls > Group Call**.

1. Select **Phonebook** to make a call to a group saved in your Phonebook, or
2. Select **Recent Calls** to make a call to a group that you have called recently, or
3. Select **Enter MMSI** to manually enter the MMSI number of the group you want to contact.
4. Select a group or enter an MMSI manually and press the **OK** button.
5. Select the Channel you want to transmit the call on.

The radio will wait for an acknowledgement to be received.

6. If an acknowledgement is received, press the **OK** button.
7. Press and hold the **PTT** button and speak your message.
8. Release the **PTT** button when you have completed your message.

Receiving a group call

Note:

To receive a call made to a Group, the Group's MMSI number must be saved in your Phonebook.

With an incoming group call displayed:

1. Select **Show info** from the options to review relevant call details.
2. Select **Reply on Ch ##** at any time to accept the call.

If auto channel change is turned on then the channel will automatically change after 10 seconds.

The radio is re-tuned to the specified channel.

3. To reject the call, select **Reject**.
4. If you rejected the call, select a reason for the rejection from the list.

Confirmation of the acceptance or rejection of the call is displayed. If you have accepted the call then the radio will re-tune to the requested channel.

7.7 Position requests

The radio can request position information from any station capable of responding to the request.

Position requests can be sent to any contact stored in the **Phonebook** or by manually inputting the station's MMSI number.

When connected to a Raymarine® multifunction display (MFD) the position data from the request can also be display in the Chart app.

Making a position request

You can request the position of another station.

From the **Position Request** menu: **Menu > DSC Calls > Position Request**.

1. Select **Phonebook** to request the position of a contact saved in your Phonebook, or
2. Select **Recent Calls** to request the position of a contact that you have called recently, or
3. Select **Enter MMSI** to manually enter the MMSI number of the station that you want to request the position of.
4. Select a contact or enter an MMSI manually and press the **OK** button.
The position request is sent. When a response is received the position of the contact is displayed.

Responding to a position request

With a Position request displayed:

1. Select **Send position** to respond with your current location, or
2. Select **Cancel** to ignore the request.
3. If the position reply is set to manual then select **SEND** to send the position report.
4. Select **OK** to resume normal operation.

If the **Position requests** setting, found in the **GPS set-up** menu is set to **Auto accept** then the response is sent automatically.

Setting automatic response to position requests

You can configure your radio to respond to incoming position requests automatically.

From the **DSC set-up** menu: **Menu > Set-up > DSC set-up**

1. Select **Position requests** to switch between Manual accept (default) and Auto accept.

7.8 Phonebook

The Phonebook can be used to save up to 100 contacts.

You can add, edit and delete contacts stored in the Phonebook.

Adding a Phonebook entry

You can save contacts in the Phonebook by entering their MMSI and assigning a name to the contact.

From the **DSC Calls** menu: **Menu > DSC Calls**.

1. Select **Phonebook**.
2. Select **Add new**.
3. Select the type of contact.
 - Vessel
 - Group
 - Coast station
4. Use the **Channel Up** and **Channel Down** buttons to cycle through the available numbers and press **OK** to confirm and move to the next digit.
5. Press the **OK** button to confirm the MMSI.
6. Use the **Channel Up** and **Channel Down** buttons to cycle through the available characters and press **OK** to confirm and move to the next character.

The maximum length for contact names is 10 characters.

7. If the Contact name is less than 10 characters, press and hold the **OK** button and select **Save**.
8. Press the **Back** button at any time to edit characters you have already entered.
9. Press and hold the **OK** button and select **Move cursor** to edit an existing character.
10. When complete press the **OK** button to return to the Phonebook.

Editing a Phonebook entry

From the **DSC Calls** menu: **Menu > DSC Calls**.

1. Select **Phonebook**.
2. Select the contact you want to edit.
3. Select **Edit name** or **Edit MMSI**
The contact's MMSI or name is displayed.
4. Use the **Channel Up** and **Channel Down** buttons to change a character.
5. Press the **OK** button to confirm each character and move to the next.
6. When you have completed your changes press the **OK** button again to save the changes.

Deleting a Phonebook entry

From the **DSC Calls** menu: **Menu > DSC Calls**.

1. Select **Phonebook**.
2. Select the contact you want to edit.
3. Select **Delete**.
4. Select **Yes**.

The contact is deleted.

7.9 Call logs

All DSC calls are logged.

The following call types are recorded in call logs:

- distress
- distress relay
- distress acknowledgements
- sent position requests
- received position requests
- group calls
- all ship calls
- individual (routine) calls

The details below are recorded for each call:

- MMSI number(s) (If a call is relayed up to 3 MMSI numbers can be recorded)
- type of call
- date and time of call
- latitude and longitude (if sent with the call)
- nature of distress (specified distress calls only)

If the call was received from a contact in the Phonebook then the contact name is displayed, otherwise the MMSI number is displayed.

Accessing the call logs

Follow the steps below to access the call logs.

From the **DSC Calls** menu: **Menu > DSC Calls**.

1. Select **Call logs**.
2. Select the log you want to view:
 - Unread
 - Distress calls
 - Non-distress calls
 - Outgoing calls
 - Position log
3. Select a call and press the **OK** button to view details.
4. Select **Options** to view available options.
 - **Call Back** — return a received call.
 - **Resend** — only available in the outgoing call log.
 - **Call** — available in the position log.
 - **Send position** — available in the position log.
 - **Request position** — available for individual and distress calls.
 - **Save to Phonebook** — available for received and outgoing calls to new contacts.
 - **Send ACK** — available for unacknowledged individual received calls.
 - **Delete** — deletes the log entry.

7.10 Test calls

A Test Call feature is available for the purposes of testing your DSC VHF radio for correct operation.

There are 2 types of test call:

- Test call to the US Coast Guard automated response test call service (MMSI: **003669999**). This type of test call will receive an automated response (acknowledgement).
- Test call to another vessel that has a radio that supports the test call feature. Your radio will automatically acknowledge test calls received from other radios.

For radios that do NOT support the test call feature, correct radio operation can be tested by making an Individual call on channel 70 to another DSC VHF radio.

It is recommended that once you've successfully placed a test call you add the test call MMSI to your radio's Phonebook for easy retrieval for future test calls. For information on how to add an MMSI to your radio's Phonebook, refer to the "Adding a Phonebook entry" section.

Note:

Individual calls (that is, NOT a test call) to the US Coast Guard 003669999 MMSI will NOT receive an automated response.

Note:

The US Coast Guard automated response test call service is only available in the United States and its coastal waters.

Making a Test call

From the **Test call** menu: **Menu > DSC Calls > Test call**.

1. Select **Phonebook** to make a test call to a contact saved in your Phonebook, or
2. Select **Recent Calls** to make a test call to a contact that you have called recently, or
3. Select **Enter MMSI** to manually enter the MMSI number of the station you want to send a test call.
4. Select a contact or enter an MMSI manually and press the **OK** button.

The test call is sent.

5. If you called the US Coast Guard automated response test call MMSI (003669999), wait for an acknowledgement. If you made a test call to another vessel with a test call capable radio, your radio will wait for a response.

When an acknowledgement is received, an audible alarm is sounded and the message (envelope) icon is displayed.

Receiving a test call

Your radio will automatically acknowledge received Test calls from other stations

When a Test call is received a notification is displayed to alert you that a test call has been received and automatically acknowledged.

7.11 DSC set-up menu options

The DSC set-up menu options can be accessed from the following menus:

- **Menu > DSC Calls > DSC set-up**
- **Menu > Set-up > DSC set-up**

Menu item	Description	Options
MMSI	To enable the DSC functions on your radio you must enter your unique MMSI number.	
Auto channel change	When automatic channel change is turned on the radio will automatically re-tune after 10 seconds to the requested channel when DSC calls are received.	<ul style="list-style-type: none">• On (default)• Off
Position requests	With Position requests set to Auto accept the radio will automatically send out position details when a position request is received.	<ul style="list-style-type: none">• Auto accept (default)• Manual accept

Chapter 8: VHF operations

Chapter contents

- 8.1 Watch modes on page 130
- 8.2 Scan Mode on page 131
- 8.3 Priority channels on page 132
- 8.4 Sensitivity on page 133
- 8.5 Private channels on page 134
- 8.6 Automatic Transmitter Identification System (ATIS) and Marcom-C mode on page 135
- 8.7 AIS receiver on page 136
- 8.8 Set-up menu options on page 137

8.1 Watch modes

Watch mode monitors priority channels and the currently selected channel.

There are 2 types of watch mode; **Dual watch** and **Triple watch** or **Tri watch**.

- **Dual watch** — This mode monitors priority channel 16 and the currently selected channel.
- **Triple watch** — This mode monitors priority channel 16, the second priority channel (Channel 09 (default)) and the currently selected channel. The second priority channel can also be set to a user defined channel.

When the radio detects a transmission, Watch mode is suspended until the transmission ends; watch mode will then recommence.

Setting Watch mode

From the **Watch Mode** menu: **Menu > Watch Mode**.

1. Select **Dual Watch** or **Triple Watch** as required.
The radio is now in Watch mode.
2. Select **2nd priority channel** to select a different second priority channel for Triple watch.
3. During Watch mode, press the **Back** button at any time to end the Watch mode and resume normal operation.

8.2 Scan Mode

Scan mode enables automatic searching for channels that are currently broadcasting.

Scan mode will search through available channels and stop when it finds a channel that is currently broadcasting. If the broadcast stops or is lost for more than 5 seconds then the scan will resume.

Channels can be temporarily removed from an active scan, and the direction of scan can also be changed. When the scan reaches the last channel in the band the scan cycle is repeated.

The following scans options are available:

- **All Channels** — All channels in the frequency band the radio is set to are scanned in sequence.
- **All Channels + 16** — All channels in the frequency band the radio is set to are scanned, after each channel is scanned priority channel 16 is scanned.
- **Saved Channels** — Only channels saved to the radio's memory are scanned in sequence.
- **Saved Channels + 16** — Only channels saved to the radio's memory are scanned, after each channel is scanned priority channel 16 is scanned.

Note:

If the weather alert function is activated, the weather alert channel is included in the scan.

Setting Scan mode

Scan mode is started from the main menu.

From the **Scan Mode** menu: **Menu > Scan Mode**.

1. Select the relevant Scan mode.
The radio is now in Scan mode.
2. Select **Edit Saved Channels** to select the channels that will be scanned when performing a Saved channel scan.
3. During Scan mode, press the **Back** button at any time to end the Scan mode and resume normal operation.

8.3 Priority channels

Channel 16 is the dedicated priority channel.

The default secondary priority channel is channel 09. The second priority channel can be changed if desired.

Switching between priority channels

1. Press the **16 / +** button to switch between priority channels.

Setting a second priority channel

You can select which channel you want to use as the second priority channel.

From the **Channel set-up** menu: **Menu > Set-up > Channel set-up**.

1. Select **2nd priority channel**.
2. Select the channel that you want to assign as the second priority channel.

8.4 Sensitivity

The sensitivity level of the radio can be set to Local mode or Distant mode.

Local mode decreases the receiver sensitivity in high traffic areas to reduce unwanted reception. When in Local mode the 'Loc' icon is displayed in the status bar.

Distant mode sets the receiver sensitivity to full.

Switching sensitivity modes

You can switch between Local and Distant modes at any time.

From the **Set-up** menu: **Menu > Set-up**.

1. Select **Sensitivity**.

Selecting Sensitivity will switch between Local mode and Distant mode (default).

8.5 Private channels

The radio may be able to receive additional Private channels depending on the country it is used in and whether the appropriate licenses are held.

The following Private channel sets can be selected:

- None
- Belgium
- Denmark (pleasure)
- Denmark (fishing)
- Finland (pleasure)
- Finland (fishing)
- Holland (Netherlands)
- Norway (pleasure)
- Norway (fishing)
- Sweden (pleasure)
- Sweden (fishing)
- UK

Selecting a private channel set

You can select the set of private channels you want to use.

From the **Channel set-up** menu: **Menu > Set-up > Channel set-up**.

1. Select **Private channels**.

The list of private channel sets is displayed:

2. Select the required private channel set.

8.6 Automatic Transmitter Identification System (ATIS) and Marcom-C mode

ATIS is a European system used on some inland waterways.

VHF radios operating in an ATIS region must be programmed with a unique ATIS number; this can be obtained from the relevant licensing authority. The ATIS number is attached as a digital signal at the end of each transmission and identifies you to the relevant authorities who monitor the system.

When operating in ATIS mode, some of the products features are not available:

- Use of DSC functions is not permitted in ATIS regions.
- Watch modes are not permitted in ATIS regions.
- Channel scanning is not permitted in ATIS regions.
- ATIS regulations restrict the transmit power to 1 watt for the following channels: 6, 8, 10, 11, 12, 13, 14, 71, 72, 74 and 77.

You can enable or disable ATIS using the menus (except on Marcom-C configured units).

Marcom-C mode

Marcom-C mode is a restricted radio configuration for VHF operators with a Marcom-C license. This is applicable to radios operated exclusively in European inland waterways using the ATIS system.

A Marcom-C VHF radio has the ATIS permanently enabled. You will not be able to disable ATIS operation. Marcom-C operation is set by the dealer at point of sale. If you wish to enable or disable Marcom-C mode, you must contact your Raymarine dealer.

For further information please contact Raymarine technical support.

Enabling and disabling ATIS mode

ATIS is a European system used on some inland waterways. A unique ATIS ID must be entered before ATIS mode can be enabled.

With ATIS mode enabled the radio's region will be fixed to the INT (international) frequency band and the following functions are disabled:

- DSC functions
- Watch Mode
- Scan Mode
- High/low power is restricted on certain channels

From the Main menu.

1. Select **Set-up**.
2. Select **ATIS set-up**.
3. Select **ATIS**.

If no ATIS ID has been set then you will be requested to enter one before ATIS mode is enabled.

4. If an ATIS ID has already been set then select **On** to enable ATIS mode or **Off** to disable ATIS mode.

8.7 AIS receiver

Depending on variant your radio may have a built-in AIS receiver.

With the built-in AIS receiver switched on AIS information can be sent to a connected Raymarine® MFD using either NMEA 0183 or SeaTalkng®.

Note: If using the built-in AIS receiver and outputting over NMEA 0183, ensure that the baud rate is set to **0183 High speed: Menu > Set-up > Network output** .

Switching AIS on and off

From the **Set-up** menu: **Menu > Set-up**.

1. Select **AIS**.

Selecting AIS will switch the internal AIS receiver On and Off.

8.8 Set-up menu options

The Set-up menu options can be accessed from the Main menu.

Menu	Description	Options
Display set-up	Provides access to the display settings menu.	<ul style="list-style-type: none"> • Backlight • Shared brightness • Contrast • Homescreen display
Language	Enables selection of the user interface language.	<ul style="list-style-type: none"> • English — English • Español — Spanish • Français — French • Deutsch — German • Italiano — Italian
Units	Provides access to units of measure selection settings.	<ul style="list-style-type: none"> • Time format • Time offset • Bearing mode • Speed unit
Power output	Switches the Power output of the radio.	<ul style="list-style-type: none"> • Distant (default) • Local
Sensitivity	Switches the Sensitivity of the radio.	<ul style="list-style-type: none"> • Low • High (default)
Noise cancelling (Tx)	Switches the transmission noise cancellation feature On and Off.	<ul style="list-style-type: none"> • On (default) • Off
Wireless set-up	Provides access to settings which apply to wireless devices. <div style="border: 1px solid black; padding: 5px; width: fit-content;"> <p>Note: Menu only available when a Wireless hub is connected.</p> </div>	<ul style="list-style-type: none"> • Wireless hub set-up • Wireless hub • Wireless speaker
Key Beep	Enables adjustment of the beep which is heard when pressing buttons.	<ul style="list-style-type: none"> • Off • Quiet (default) • Loud
Channel set-up	Provides access to the Channel set-up menu.	<ul style="list-style-type: none"> • Channel name • 2nd priority channel • Private channels • Frequency band
GPS set-up	Provides access to the GPS set-up menu.	<ul style="list-style-type: none"> • Internal GPS • Homescreen display • Bearing mode • Position requests • Set manual position
DSC set-up	Provides access to the DSC set-up menu.	<ul style="list-style-type: none"> • MMSI • Auto channel change • Position requests

Menu	Description	Options
AIS	Switches the internal AIS receiver on and off on. Note: Menu only available on Ray91.	<ul style="list-style-type: none"> • Off (default) • On
Network output	Enables you to select the network to be used to output and receive data.	<ul style="list-style-type: none"> • NMEA 2000 • 0183 High speed • 0183 Std speed
ATIS set-up	Enables you to switch ATIS mode on and off and enter your ATIS ID.	<ul style="list-style-type: none"> • ATIS • ATIS ID
Maintenance	Enables you to view system details and functions that may be required during maintenance and troubleshooting.	<ul style="list-style-type: none"> • About this unit • System reset • System test

Display Set-up menu

The following menu options are available form the Display Set-up menu.

Menu	Description	Options
Backlight	Increases and decreases the LCD and button backlight level.	<ul style="list-style-type: none"> • 0 to 9 • Off
Shared brightness	Enables set-up of Shared Brightness.	<ul style="list-style-type: none"> • Shared brightness • Group
Contrast	Increases and decreases the LCD Contrast level.	<ul style="list-style-type: none"> • 0 to 10
Homescreen display	Determines the details displayed onscreen.	<ul style="list-style-type: none"> • Location & Time • Location & COG/SOG

Shared Brightness menu

The following menu options are available form the Shared Brightness menu.

Menu	Description	Options
Shared brightness	Enables and disables Shared Brightness.	<ul style="list-style-type: none"> • On • Off
Group	Enables you to assign the radio to a Shared Brightness group.	<ul style="list-style-type: none"> • Helm 1 • Helm 2 • Cockpit • Flybridge • Mast • Group 1 to Group 5

Chapter 9: Hailer, Fog horn, and Intercom

Chapter contents

- [9.1 Hailer Fog Intercom menu on page 140](#)
- [9.2 Loud Hailer on page 141](#)
- [9.3 Fog horn on page 142](#)
- [9.4 Intercom on page 143](#)

9.1 Hailer Fog Intercom menu

The menu options available are determined by the accessories connected to your radio.

Menu name	Connected devices
Hail/Fog/Int	Loud hailer and second station connected.
Hailer/Fog	Loud hailer connected, no second station
Intercom	Second station connected, no loud hailer

Note:

For simplicity the procedures in this section all refer to the **Hail/Fog/Int** menu.

9.2 Loud Hailer

The Ray70, Ray90 and Ray91 can be connected to a Loud Hailer.

In Hailer mode anything spoken into the handset is amplified and broadcast from the hailer. The message is not transmitted over VHF/DSC.

When the hailer is active VHF calls cannot be sent or received.

Using the hailer

From the **Hail/Fog/Int** menu: **Menu > Hail/Fog/Int**.

1. Select **Hailer**.
Hailer mode is now active
2. Press and hold the **PTT** button.
3. Speak your message.
4. Release the **PTT** button.
5. Press the **Back** button to exit Hailer mode.
6. The hailer listening volume can be adjusted at any time in Listening mode using the **Volume Control**.
7. The hailer talking volume can be adjusted at any time, with the **PTT** button pressed using the **Volume Control**.

9.3 Fog horn

The fog horn function requires an optional loud hailer to be connected. Please check your product description to ensure a loud hailer can be connected.

The fog horn function can be set to manual or to predefined automatic modes.

In manual mode a continuous tone is sounded for as long as the **PTT** button is pressed.

In automatic mode the selected tone will repeat every 2 minutes until interrupted or cancelled. In automatic mode the radio can be used as normal between the fog horn patterns.

Fog mode	Description	Pattern
Underway	Vessel underway	1 long tone
Underway/Stopped	Vessel not underway	2 long tones
Sailing/Fishing	sailing vessel or any vessel fishing but not trolling	1 long tone and 2 short tones
Restrict/Tow	Restricted in ability to maneuver or towing another vessel	1 long tone and 2 short tones
Under tow	This vessel is being towed	1 long tone and 3 short tones
Pilot vessel	This vessel is a pilot vessel	4 short tones
At anchor	Vessel is at anchor	12 consecutive rings
Aground	Vessel is aground	3 short rings, 12 consecutive rings, 3 short rings

Using the fog horn in manual mode

From the **Hail/Fog/Int** menu: **Menu > Hail/Fog/Int**.

1. Select **Fog horn**.
2. Select **Manual mode**.
3. Press and hold the **PTT** button to sound a continuous fog horn tone.
4. Press the **Back** button to exit Fog horn mode.

Using automatic fog horn modes

From the **Hail/Fog/Int** menu: **Menu > Hail/Fog/Int**.

1. Select **Fog horn**.
2. Select **Automatic mode**.
3. Select an automatic pattern.
The selected pattern will play and repeat until interrupted.
4. Select **Stop fog horn** to exit the automatic fog horn mode, or
5. Select **Change pattern** to select a different fog horn pattern.
6. To continue using the radio whilst in automatic fog horn mode select **Back** 4 times to return to the Homescreen.

You can now continue to use the radio as normal. The fog horn pattern will continue to repeat every 2 minutes. If you are making a call when it is due to sound the fog horn will be suspended until you finish your call.

Switching off Fog Horn mode

Automatic Fog Horn mode will remain active until switched off.

From the **Hail/Fog/Int** menu: **Menu > Hail/Fog/Int**.

1. Select **Fog horn**.
2. Select **Stop fog horn** to switch off the automatic fog horn mode

9.4 Intercom

The Intercom function is available when more than 1 station is connected to your radio.

The intercom function allows voice communication between handset stations. Calls can be initiated from either station.

Using the intercom

From the **Hail/Fog/Int** menu: **Menu > Hail/Fog/Int**.

1. Select **Intercom**.
2. ⁽¹⁾Select the handset you want to call.
The selected handset will ring.
3. Wait for the handset station to acknowledge the call.
4. Press and hold the **PTT** button and speak your message.

Note:

⁽¹⁾Step not required when only 2 handsets are connected.

Responding to the intercom

1. Press the **PTT** button and acknowledge the call and to respond to subsequent voice messages.

Chapter 10: Maintenance

Chapter contents

- [10.1 Maintenance on page 146](#)

10.1 Maintenance

This product has no user serviceable parts or adjustments. Never remove the cover or attempt to service the product, doing so may invalidate your product warranty.

The following preventive measures should be followed:

- Although the product is waterproof, keep the unit as dry as possible.
- If you remove a connection ensure a dust cap is fitted to the connector.

Routine checks

The following periodic checks should be made:

- Examine cables for signs of damage, such as chafing, cuts or nicks.
- Check that the cable connectors are firmly attached and that their locking mechanisms are properly engaged.

Note: Cable checks should be carried out with the power supply switched off.

Caution: Product cleaning

When cleaning products:

- Lightly rinse or flush with clean, cool fresh water.
- If your product has a display screen, do NOT wipe the screen with a dry cloth, as this could scratch the screen coating.
- Do NOT use: abrasive, acidic, ammonia, solvent or chemical based cleaning products.
- Do NOT use a jet wash.

Unit cleaning instructions

The unit does not require regular cleaning. However, if you find it necessary to clean the unit, please follow the steps below:

1. Ensure power is switched off.
2. Wipe unit clean with a damp cloth.
3. If necessary, use a mild detergent solution to remove grease marks.

Chapter 11: Troubleshooting



Chapter contents

- [11.1 LED diagnostics — Base station on page 148](#)
- [11.2 LED diagnostics - Wireless \(Active\) speaker on page 149](#)
- [11.3 Troubleshooting on page 150](#)
- [11.4 Power up troubleshooting on page 151](#)
- [11.5 VHF Radio troubleshooting on page 153](#)
- [11.6 GNSS \(GPS\) troubleshooting on page 154](#)
- [11.7 Wireless troubleshooting on page 155](#)

11.1 LED diagnostics – Base station

Sequence	Color	Status
	Green	<ul style="list-style-type: none"> • SeaTalkng®Bus healthy, no communication faults. • All modules ready (GPS, VHF, AIS).
	Red	<ul style="list-style-type: none"> • SeaTalkng®Bus not connected. • NMEA 0183 connected.
	Red	<ul style="list-style-type: none"> • Connected but not receiving data.
	Green	<ul style="list-style-type: none"> • VHF transceiver module initializing / not ready.
	Green	<ul style="list-style-type: none"> • GNSS (GPS sensor initializing / not ready).
	Red	<ul style="list-style-type: none"> • Internal fault (No GNSS signal, No antenna, lost signal).

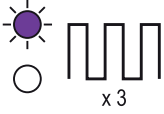
11.2 LED diagnostics - Wireless (Active) speaker

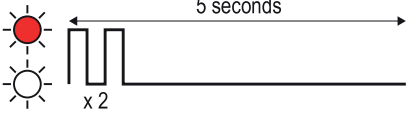
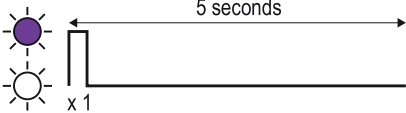
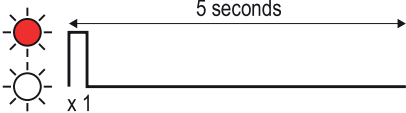
Sequence	Color	Status
	Purple	Powering on
	Red and Blue	Ready to pair/connect
	Red	Paired ok
	Red	Connected, no audio
	Purple	Connected, audio active
	Red	Powered on, not connected

11.3 Troubleshooting

The troubleshooting information provides possible causes and corrective action required for common problems associated with installation and operation of your product.

Before packing and shipping, all Raymarine products are subjected to comprehensive testing and quality assurance programs. If you do experience problems with your product this section will help you to diagnose and correct problems in order to restore normal operation.

If after referring to this section you are still having problems with your product, please refer to the Technical support section of this manual for useful links and Raymarine Product Support contact details.

Performing a system reset

Note: Performing a reset will not reset MMSI and ATIS ID number.

From the Maintenance menu: **Menu > Set-up > Maintenance.**

1. Select **System reset**.
2. Select **Yes**.

The system is now reset to factory defaults.

Note: Performing the reset will delete all contacts in your phonebook and reset all user options.

System test

The system test menu can be used to show the status of the system and connected devices.

The System test menu show the status of the following system components and connected devices:

- GPS
- DSC
- Battery
- Hailer
- Remote handset
- **OK** is displayed next to each item that is either connected or enabled
- **No** is displayed next to items that are either not connected or disabled.

11.4 Power up troubleshooting

Problems at power up and their possible causes and solutions are described here.

Product does not turn on or keeps turning off

Possible causes	Possible solutions
Blown fuse / tripped breaker	<ol style="list-style-type: none"> 1. Check condition of relevant fuses and breakers and connections, replace if necessary (Refer to Chapter 13 Technical specification for fuse ratings.) 2. If fuse keeps blowing check for cable damage, broken connector pins or incorrect wiring.
Poor / damaged / insecure power supply cable / connections	<ol style="list-style-type: none"> 1. Check that the power cable connector is fully inserted into the unit and locked in position. 2. Check the power supply cable and connectors for signs of damage or corrosion, replace if necessary. 3. With the unit turned on, try flexing the power cable near to the display connector to see if this causes the unit to re-boot/lose power, replace if necessary. 4. Check the vessel's battery voltage, the condition of the battery terminals and power supply cables, ensuring connections are secure, clean and free from corrosion, replace if necessary. 5. With the product under load, using a multi-meter, check for high voltage drop across all connectors/fuses etc, replace if necessary.
Incorrect power connection	The power supply may be wired incorrectly, ensure the installation instructions have been followed. (Refer to Chapter 4 Cables and connections for cable and connection requirements.)
Power source insufficient	With the product under load, using a multi-meter, check the power supply voltage as close to the unit as possible to establish actual voltage when the current is flowing. (Refer to Chapter 13 Technical specification for power supply requirements.)

Product will not boot up (re-boot loop)

Possible causes	Possible solutions
Power supply and connection	See possible solutions from 'Products does not turn on or keeps turning off' above.
Software corruption	In the unlikely event that the products software has become corrupted please try re-flashing the latest software from the Raymarine website.

Product does not turn on or keeps turning off

Possible causes	Possible solutions
Blown fuse / tripped breaker	<ol style="list-style-type: none"> 1. Check condition of relevant fuses and breakers and connections, replace if necessary (Refer to Chapter 13 Technical specification for fuse ratings.) 2. If fuse keeps blowing check for cable damage, broken connector pins or incorrect wiring.
Poor / damaged / insecure power supply cable / connections	<ol style="list-style-type: none"> 1. Check that the power cable connector is fully inserted into the unit and locked in position. 2. Check the power supply cable and connectors for signs of damage or corrosion, replace if necessary.

Possible causes	Possible solutions
	<ol style="list-style-type: none"> 3. With the unit turned on, try flexing the power cable near to the display connector to see if this causes the unit to re-boot/loose power, replace if necessary. 4. Check the vessel's battery voltage, the condition of the battery terminals and power supply cables, ensuring connections are secure, clean and free from corrosion, replace if necessary. 5. With the product under load, using a multi-meter, check for high voltage drop across all connectors/fuses etc, replace if necessary.
Incorrect power connection	The power supply may be wired incorrectly, ensure the installation instructions have been followed. (Refer to Chapter 4 Cables and connections for cable and connection requirements.)
Power source insufficient	With the product under load, using a multi-meter, check the power supply voltage as close to the unit as possible to establish actual voltage when the current is flowing. (Refer to Chapter 13 Technical specification for power supply requirements.)

Wired handset will not power up

Possible causes	Possible solutions
Handset not turned on	The Wired handset is compatible with the Ray60, Ray63, Ray70, Ray73, Ray90 and Ray91 radios. The Wired handset is supplied power from the Base station. Press the Power button located on the top of the Handset to power it on.
Software Base station / Handset mismatch	The Handset and Base station must both be running compatible software, refer to the ' <i>Software updates</i> ' section or the
Poor / damaged / insecure cables / connections	<ol style="list-style-type: none"> 1. Check that the Base station is correctly powered. 2. With the Handset turned on, try flexing the cable near to the connectors to see if this causes the Handset to re-boot/loose power, replace if necessary. 3. Check cable connections are secure, clean and free from corrosion, replace if necessary.

11.5 VHF Radio troubleshooting

Problems with your VHF radio and their possible causes and solutions are described below:

DSC functions are not available / working

Possible Causes	Possible Solutions
MMSI number not programmed.	Programme your MMSI number.
Radio is set to ATIS or Marcom-C mode.	Use of DSC is not permitted when in ATIS or Marcom-C mode. You will be unable to make DSC distress and other types of digital selective call. If you are not in an ATIS region switch off ATIS mode: Menu > Set-up > ATIS set-up > ATIS.
Sensitivity set to Local.	With the sensitivity set to Local your reception will be limited Set Sensitivity to Distant: Menu > Set-up > Sensitivity.

Passive speaker no alarm audio

Possible Causes	Possible Solutions
Passive speaker connected to second station connector.	Alarm audio is not available on passive speakers connected to the second station connector. Alarm audio should still be heard via the second station handset.

11.6 GNSS (GPS) troubleshooting

Problems with the GNSS (GPS) and their possible causes and solutions are described below. Before troubleshooting GNSS (GPS) problems, ensure your product has the latest software.

No fix

Possible causes	Possible solutions
No GNSS (GPS) receiver connected.	In order to obtain a position fix your product requires a GNSS (GPS) receiver. Your product may include an internal GNSS (GPS) receiver, if not then an external GNSS (GPS) receiver such as the RS150 is required.
No antenna connected to GNSS (GPS) receiver.	Depending on variant, your product may include an internal GNSS (GPS) receiver. The receiver may or may not include an internal antenna. If your product's internal GNSS (GPS) receiver does not include an internal antenna then you will need to connect an external passive antenna to the GNSS (GPS) / GA150 connection.
GNSS (GPS) Antenna location.	For optimum performance, external GNSS (GPS) antennas and GNSS (GPS) receivers that include an internal antenna should be mounted above decks and have a clear, unobstructed view of the sky, and not be in close proximity to any structural bulkheads or other electrical equipment or cables which may cause interference.
GNSS (GPS) switched off.	Ensure your internal GNSS (GPS) receiver is switched on in the relevant settings menu.
Geographic location or prevailing conditions preventing satellite fix.	Check periodically to see if a fix is obtained in better conditions or another geographic location.

No position data

Possible causes	Possible solutions
Internal receiver is switched off.	Ensure your external or internal receiver is switched on.
Wrong Network output selected.	Ensure the correct network type and speed is selected in the Network output menu: Menu > Set-up > Network output .
Poor / damaged / insecure cable / connection.	<ol style="list-style-type: none"> 1. Check that the connectors are fully inserted into the unit and locked in position. 2. Check the cables and connectors for signs of damage or corrosion, replace if necessary. 3. Check the vessel's battery voltage, the condition of the battery terminals and power supply cables, ensuring connections are secure, clean and free from corrosion, replace if necessary. 4. With the product under load, using a multi-meter, check for high voltage drop across all connectors/fuses etc, replace if necessary.

GNSS (GPS) data output

The Ray90 and Ray91 include an internal GNSS (GPS) receiver. However, these products do NOT output position data to external devices.

11.7 Wireless troubleshooting

Before troubleshooting problems with your wireless connection, ensure that you have followed the Wireless location requirements guidance provided in the relevant installation instructions and performed a power cycle/reboot of the devices you are experiencing problems with.

Wireless handset not powering up

Possible cause	Possible solutions
Wireless handset's battery is not charged.	<ol style="list-style-type: none"> 1. Ensure the handset's charging holster is correctly connected to a 12 V dc power supply. 2. Place the handset in the charging holster. 3. Ensure the battery symbol is displayed on the handset screen.

Cannot find network

Possible cause	Possible solutions
Devices not powered or connected.	Ensure the Wireless hub is connected to the Hub connection on the Ray90 / Ray91 Base station and that the Case station is powered on.
Devices out of range or signal being blocked.	Move devices closer together or, if possible remove the obstructions and then rescan available networks.

Cannot connect to hub

Possible cause	Possible solutions
Trying to connect to the wrong device.	Ensure you are trying to connect to the correct device, you can find your Wireless hub's name using a Wired handset and going to the Wireless hub set-up menu, and looking under Hub name (Menu > Set-up > Wireless set-up > Wireless hub set-up > Hub name) .
Incorrect password.	Ensure you are trying to connect using the correct password, you can find your Wireless hub's password using a Wired handset and going to the Wireless hub set-up menu, and looking under Password (Menu > Set-up > Wireless set-up > Wireless hub set-up > Password) .
Bulkheads, decks and other heavy structure can degrade and even block the wireless signal. Depending on the thickness and material used it may not always be possible to pass a wireless signal through certain structures	<ol style="list-style-type: none"> 1. Try repositioning the Wireless hub so that the structure is removed from the direct line of sight between the devices, or 2. Use the Wireless hub antenna extension accessory: A80541 to move the area covered by your wireless hub.

Connection extremely slow and or keeps dropping out

Possible cause	Possible solutions
Wireless performance degrades over distance so products farther away will receive less network bandwidth. Products installed close to their maximum wireless range will experience slow connection speeds, signal drop outs or not being able to connect at all.	Move devices closer together.
Interference being caused by other wireless enabled devices.	<ol style="list-style-type: none"> 1. Change the hub's wireless channel and retry the connection. You can use free wireless analyzer apps on your smartphone or tablet to help you choose a less congested channel. 2. Switch off each wireless device in turn until you have identified the device causing the interference.
Interference caused by other devices that use the 2.4GHz frequency See list below of some common devices that use the 2.4GHz frequency: <ul style="list-style-type: none"> • Microwave ovens • Fluorescent lighting • Cordless phones / baby monitors • Motion sensors 	Switch off each device in turn until you have identified the device causing the interference, then remove or reposition the offending device(s) or your wireless hub / handset..
Interference caused by electrical and electronic devices and associated cabling could generate an electromagnetic field which may interfere with the wireless signal.	Switch off each item in turn until you have identified the device causing the interference, then remove or reposition the offending device(s) or your wireless hub / handset.
Interference from devices on other vessels. When in close proximity to other vessels, for example, when moored up in a marina, many other wireless signals may be present.	<ol style="list-style-type: none"> 1. Change the hub's wireless channel and retry the connection. You can use free wireless analyzer apps on your smartphone or tablet to help you choose a less congested channel. 2. If possible, move your vessel to a location with less wireless traffic.

Network connection established but no data

Possible cause	Possible solutions
Connected to the wrong network.	Ensure that your handset is connected to the correct Wireless hub.
Device software incompatibility.	Ensure both devices are running the latest available software. You can check device software from the Maintenance menu: Menu > Set-up > Maintenance > About this unit.
It may be possible that the device has become defective.	<ol style="list-style-type: none"> 1. Try updating software to a later version, or try reinstalling the current software. 2. Contact technical support for further assistance.

Chapter 12: Technical support

Chapter contents

- [12.1 Raymarine product support and servicing on page 158](#)
- [12.2 Viewing product information on page 160](#)
- [12.3 Learning resources on page 161](#)

12.2 Viewing product information

Product information can be found on the Startup screen.

1. Power up the radio.

The startup screen is displayed which shows the model and software version of the product.

Alternatively product information can also be displayed by selecting **About this unit** from the **Maintenance** menu: **Menu > Set-up > Maintenance**.

Chapter 13: Technical specification

Chapter contents

- 13.1 Technical specification — Base station on page 164
- 13.2 Technical specification — Wired handset (Raymic) on page 166
- 13.3 Technical specification - Wired (Passive) speaker on page 167
- 13.4 Technical specification - Wireless hub on page 168
- 13.5 Technical specification - Wireless handset on page 169
- 13.6 Technical specification - Wireless handset charging holster on page 170
- 13.7 Technical specification - Wireless (Active) speaker on page 171
- 13.8 Radio usage on page 172

13.1 Technical specification — Base station

The following technical specification apply to the Ray90 and Ray91.

Power specification

Nominal supply voltage	12 V dc (with over voltage protection)
Operating voltage range	10.2 V dc to 16 V dc
Fuse requirements	<ul style="list-style-type: none"> • Inline fuse = 10 A • Thermal breaker = 7 A
Current consumption	<ul style="list-style-type: none"> • Less than 6 A at high power (13.6 V) • Standby: 600 mA • Receive: 2 A • Loud hailer: 3 A (8 Ω) / 6 A (4 Ω)
LEN	1

Environmental specification

Operating temperature	-25°C (-13°F) to +55°C (131°F)
Storage temperature	-25°C (-13°F) to +70°C (158°F)
Relative humidity	95%
Water proofing	IPx6 & IPx7

Connections

Wired handsets	x 2 via HS1 and HS2 connectors
Wireless hub	x 1 via Hub connector
GNSS (GPS) antenna	x 1 via GPS connector (TNC)(
VHF antenna / splitter	x 1 via VHF connector (50 Ohm SO239)
NMEA 0183 input	x 1 via bare ended wires on data cable
NMEA 0183 output	x 1 via bare ended wires on data cable
NMEA 2000 / SeaTalkng®	x 1 via N2K (DeviceNet) connector
Loud hailer	x 1 via bare ended wires on data cable.

VHF Transmitter

Channels	All available US, International and Canadian VHF marine bands
Frequency Range	156.025 MHz to 157.425 MHz / 155.500 MHz to 161.425 MHz (Private channels)
Frequency stability	+/- 1.5 ppm
Channel Spacing	12.5 kHz
Power Output	<ul style="list-style-type: none"> • Low power setting — 1 W • High power setting — 25 W
Spurious emissions	Better than -36 dBm at 25 W (Less than 0.25 μW)
Maximum deviation	+/- 5 KHz
Antenna impedance	50 Ohms (typical)

Receiver

Receiver type	Double conversion super heterodyne
Channels	All available US, International and Canadian VHF marine bands

Frequency range	156.050 MHz to 163.275 MHz / 155.500 MHz to 161.425 MHz (Private channels)
Sensitivity	Better than 1 microvolt EMF @ 20dB SINAD
Squelch sensitivity	Less than -2 dB μ EMF
Hum and noise	Better than -40 dB
Audio distortion	Less than 10%
Receiver sensitivity	<ul style="list-style-type: none"> Distance — 119dBm (0.25uV) @ 12dB SINAD (typical) Local — 110dBm (0.7uV) @ 12dB SINAD (typical)
Adjacent channel selectivity	More than 70 dB
Spurious response rejection	More than 70 dB
Inter modulation rejection	More than 68 dB

GNSS (GPS)

Channels	72
Cold start	29 seconds
Receiver IC Sensitivity	<ul style="list-style-type: none"> Tracking and navigation = -167 dBm Reacquisition = -160 dBm Cold start = -146 dBm Hot start = -156 dBm
GNSS compatibility	<ul style="list-style-type: none"> GPS GLONASS Beidou
SBAS compatibility	<ul style="list-style-type: none"> QZSS WAAS EGNOS MSAS GAGAN
Special features	Active Jamming and Interference Reduction
Operating frequency	<ul style="list-style-type: none"> GPS L1 C/A GLONASS L10F Beidou B1
Signal Acquisition	Automatic
Almanac Update	Automatic
Geodetic Datum	WGS-84 (alternatives available through Raymarine MFD)
Refresh Rate	20 Hz (20 times per second Concurrent GNSS)
Antenna	<ul style="list-style-type: none"> External — An external passive antenna is required
Horizontal Position Accuracy	<ul style="list-style-type: none"> Autonomous = 2.5m (8.2 ft) SBAS = 2m (6.56 ft)

AIS (Ray91 only)

Class type	Receiver only
------------	---------------

13.2 Technical specification – Wired handset (Raymic)

The following technical specifications apply to the Wired handset.

Operating temperature	-25°C (-13°F) to +55°C (131°F)
Storage temperature	-25°C (-13°F) to +70°C (158°F)
Relative humidity	95%
Water proofing	IPx6 & IPx7
Max speaker power output	1 W (16 Ω)
VHF radio compatibility	<ul style="list-style-type: none">• Ray60• Ray70• Ray90 / Ray91

13.3 Technical specification - Wired (Passive) speaker

Operating temperature	-25°C (-13°F) to +55°C (131°F)
Storage temperature	-25°C (-13°F) to +70°C (158°F)
Relative humidity	95%
Water proofing	IPx6 & IPx7
Max speaker power output	5 W (8 Ω)
Connection	RCA female connector, connects to Wired handset via adaptor cable (A80297)
VHF radio compatibility	<ul style="list-style-type: none">• Ray50 /Ray52• Ray60• Ray70• Ray90 / Ray91

13.4 Technical specification - Wireless hub

The following technical specification applies to the Wireless hub accessory.

Operating temperature	-25°C (-13°F) to +55°C (131°F)
Storage temperature	-25°C (-13°F) to +70°C (158°F)
Relative humidity	95%
Water proofing	IPx6 & IPx7
Wireless frequency	2.4 GHz
Connections	<ul style="list-style-type: none">• Connects to Base station via 12 pin connector.• Connects to up to 3 wireless handsets via 2.4GHz wireless connection.
VHF radio compatibility	<ul style="list-style-type: none">• Ray90 / Ray91

13.5 Technical specification - Wireless handset

Wireless handset

Operating temperature	-25°C (-13°F) to +55°C (131°F)
Storage temperature	-25°C (-13°F) to +70°C (158°F)
Relative humidity	95%
Water proofing	IPx6 & IPx7
Max speaker power output	1 W (16 Ω)
Wireless frequency	2.4 GHz
Connections	<ul style="list-style-type: none">• x 1 Wireless hub connection via 2.4GHz wireless connection• x 1 Wireless (Active) speaker via 2.4GHz wireless connection
VHF radio compatibility	<ul style="list-style-type: none">• Ray90 / Ray91

Battery

Battery type	Rechargeable Lithium ion
Replaceable	No
Capacity	2000 mAh
Talk time	8 hours
Standby	100 hours
Charge time	5 hours

13.6 Technical specification - Wireless handset charging holster

Power specification

Nominal supply voltage	12 V dc (with over voltage protection)
Operating voltage range	10.2 V dc to 16 V dc
Fuse requirements	<ul style="list-style-type: none">• Inline fuse = 2 A• Thermal breaker = 2 A
Current consumption	1 A nominal
Charge type	Wireless inductive charging
Power output	1 A

Environmental specification

Operating temperature	-25°C (-13°F) to +55°C (131°F)
Storage temperature	-25°C (-13°F) to +70°C (158°F)
Relative humidity	95%
Water proofing	IPx6 & IPx7

13.7 Technical specification - Wireless (Active) speaker

Power specification

Nominal supply voltage	12 V dc (with over voltage protection)
Operating voltage range	10.2 V dc to 16 V dc
Fuse requirements	<ul style="list-style-type: none">• Inline fuse = 2 A• Thermal breaker = 2 A
Current consumption	1 A nominal
Max speaker power output	5 W (8 Ω)

Environmental specification

Operating temperature	-25°C (-13°F) to +55°C (131°F)
Storage temperature	-25°C (-13°F) to +70°C (158°F)
Relative humidity	95%
Water proofing	IPx6 & IPx7

Connections

Connection	x 1 Wireless handset connection via 2.4GHz Wireless connection
VHF radio compatibility	<ul style="list-style-type: none">• Ray90 / Ray91

13.8 Radio usage

The radio can be used worldwide, including the following European countries:

AT	CZ	FI	IE	LU	PL	SK
BE	DE	FR	IS	LV	PT	TR
BG	DK	GB	IT	MT	RO	
CH	EE	GR	LI	NL	SE	
CY	ES	HU	LT	NO	SI	

Chapter 14: Spares and accessories

Chapter contents

- 14.1 Ray90 / Ray91 spares on page 174
- 14.2 Extension cables on page 175
- 14.3 Ray90 / Ray91 accessories on page 176
- 14.4 SeaTalkng[®] cables and accessories on page 177

14.1 Ray90 / Ray91 spares

The following spares are available for the Ray90 / Ray91:

R70624	Ray90 base station
R70625	Ray91 base station
R70616	Wireless handset
R70617	Wireless handset charging holster
R70618	Volume knob for the wireless active speaker
R70619	Bezel for passive and active speaker
R70492	Wired handset holster
R70438	Panel mount fixing kit
R70484	Handset hook plate (mounting clip)

14.2 Extension cables

The following extension cables are available:

Part number	Description
A80291	Wired handset extension cable 5 m (16.4 ft)
A80292	Wired handset extension cable 10 m (32.8 ft)
A80290	Wired handset extension cable 15 m (49.2 ft)
A80297	Wired handset adaptor cable with male RCA audio (400 mm 1.3 ft)

14.3 Ray90 / Ray91 accessories

The following accessories are available for the Ray90 / Ray91:

Part number	Description
A80288	Passive GNSS (GPS) antenna
A80540	Wireless hub
A80541	Wireless hub antenna extension 5m (16.4 ft)
A80542	Wired passive speaker
A80543	Wireless active speaker
A80544	Wireless handset including charging holster
A80289	Wired handset including mounting holster
A80291	Wired handset extension cable 5 m (16.4 ft)
A80292	Wired handset extension cable 10 m (32.8 ft)
A80290	Wired handset extension cable 15 m (49.2 ft)
A80297	Wired handset adaptor cable with male RCA audio (400 mm 1.3 ft)
M95435	Loud hailer / Fog horn

14.4 SeaTalkng[®] cables and accessories

SeaTalkng[®] cables and accessories for use with compatible products.

Part No	Description	Notes
T70134	Starter kit	Includes: <ul style="list-style-type: none"> • 1 x 5 Way connector (A06064) • 2 x Backbone terminator (A06031) • 1 x 3 m (9.8 ft) spur cable (A06040) • 1 x Power cable (A06049)
A25062	Backbone Kit	Includes: <ul style="list-style-type: none"> • 2 x 5 m (16.4 ft) Backbone cable (A06036) • 1 x 20 m (65.6 ft) Backbone cable (A06037) • 4 x T-piece (A06028) • 2 x Backbone terminator (A06031) • 1 x Power cable (A06049)
A06038	Spur cable 0.4 m (1.3 ft)	
A06039	Spur cable 1 m (3.3 ft)	
A06040	Spur cable 3 m (9.8 ft)	
A06041	Spur cable 5 m (16.4 ft)	
A06042	Elbow spur cable 0.4 m (1.3 ft)	
A06033	Backbone cable 0.4 m (1.3 ft)	
A06034	Backbone cable 1 m (3.3 ft)	
A06035	Backbone cable 3 m (9.8 ft)	
A06036	Backbone cable 5 m (16.4 ft)	
A06068	Backbone cable 9 m (29.5 ft)	
A06037	Backbone cable 20 m (65.6 ft)	
A06043	SeaTalkng [®] to bare wire spur cable 1 m (3.3 ft)	
A06044	SeaTalkng [®] to bare wire spur cable 3 m (9.8 ft)	
A06049	Power cable 1 m (3.3 ft)	
A06077	Right angled connector	90° right angle spur connector.
A06031	Terminator	
A06028	T-piece	Provides 1 x spur connection
A06064	5-way connector block	Provides 3 x spur connections
A06030	Backbone extender	
E22158	SeaTalk to SeaTalkng [®] converter kit	Allows the connection of SeaTalk devices to a SeaTalkng [®] system.
A80001	Inline terminator	Provides direct connection of a spur cable to the end of a backbone cable. No T-piece required.
A06032	Spur blanking plug	
R12112	ACU / SPX SeaTalkng [®] spur cable 0.3 m (1.0 ft)	Connects an SPX course computer or an ACU to a SeaTalkng [®] backbone.
A06047	SeaTalk (3 pin) to SeaTalkng [®] adaptor cable 0.4 m (1.3 ft)	

Part No	Description	Notes
A22164	SeaTalk to SeaTalkng [®] spur cable 1 m (3.3 ft)	
A06048	SeaTalk2 (5 pin) to SeaTalkng [®] adaptor cable 0.4 m (1.3 ft)	
A06045	SeaTalkng [®] to DeviceNet (Female) adaptor cable 0.4 m (1.3 ft)	Allows the connection of NMEA 2000 devices to a SeaTalkng [®] system.
A06075	SeaTalkng [®] to DeviceNet (Female) adaptor cable 1 m (3.3 ft)	Allows the connection of NMEA 2000 devices to a SeaTalkng [®] system.
A06046	SeaTalkng [®] to DeviceNet (Male) adaptor cable 1.5 m (4.92 ft)	Allows the connection of NMEA 2000 devices to a SeaTalkng [®] system.
A06076	SeaTalkng [®] to DeviceNet (Male) adaptor cable 1 m (3.3 ft)	Allows the connection of NMEA 2000 devices to a SeaTalkng [®] system.
A06078	SeaTalkng [®] to DeviceNet (Male) adaptor cable 0.1 m (0.33 ft)	Allows the connection of NMEA 2000 devices to a SeaTalkng [®] system.
E05026	DeviceNet (Female) to bare wires adaptor cable (0.4 m (1.3 ft)	Allows the connection of NMEA 2000 devices to a SeaTalkng [®] system.
E05027	DeviceNet (Male) to bare wires adaptor cable (0.4 m (1.3 ft)	Allows the connection of NMEA 2000 devices to a SeaTalkng [®] system.

Appendix A NMEA 0183 sentences

The radio supports the following **NMEA 0183** sentences.

Sentence	Description	Ray90		Ray91	
		Receive	Transmit	Receive	Transmit
DSC	Digital Selective Calling		●		●
DSE	Expanded Digital Selective Calling		●		●
VDM	AIS VHF Data Link Message				●
GGA	Global Positioning System Fix Data	●		●	
GLL	Geographic Position — Lat/Long	●		●	
GNS	GNSS Fix Data	●		●	
RMA	Recommended Minimum Specific Loran-C Data	●		●	
RMC	Recommended Minimum Specific GNSS Data	●		●	
DTM	Datum	●		●	

Appendix B NMEA 2000 PGN list

The radio supports the following **NMEA 2000** PGNs. These are applicable to **NMEA 2000** and **SeaTalkng®** protocols.

PGN	Description	Ray90		Ray91	
		Receive	Transmit	Receive	Transmit
59392	ISO Request	●	●	●	●
59904	ISO Acknowledgement	●	●	●	●
60928	ISO Address Claim	●	●	●	●
126208	NMEA — Group Function	●	●	●	●
126464	PGN List		●		●
126996	Product Information		●		●
127258	Magnetic variation	●		●	
129026	COG / SOG Rapid Update	●		●	
129029	GNSS Position Data	●		●	
129038	AIS Class A Position Report				●
129039	AIS Class B Position Report				●
129040	AIS Class B Extended Position Report				●
129041	AIS Aids to Navigation (AtONs)				●
129044	Datum	●		●	
129793	AIS UTC and Date Report				●
129794	AIS Class A Static and Voyage Related data				●
129798	AIS SAR Aircraft Position Report				●
129801	AIS Addressed Safety Related Message				●
129802	AIS Safety Related Broadcast Message				●
129808	DSC Call Information		●		●
129809	AIS Class B “CS” Static Data Report, Part A				●
129810	AIS Class B “CS” Static Data Report, Part B				●

Appendix D VHF Channels

International Marine VHF Channels and Frequencies

CH No.	TX Freq	RX Freq (MHz)	Single Freq (MHz)	Use
01	156.050	160.650		Public correspondence, Port operations and Ship movement.
02	156.100	160.700		Public correspondence, Port operations and Ship movement.
03	156.150	160.750		Public correspondence, Port operations and Ship movement.
04	156.200	156.800		Public correspondence, Port operations and Ship movement.
05	156.250	156.850		Public correspondence, Port operations and Ship movement.
06	156.300	156.300	x	Intership. Coordinated search and rescue and ship stations working frequency
07	156.350	160.950		Public correspondence, Port operations and Ship movement.
08	156.400	156.400	x	Intership. Preferred intership channel
09	156.450	156.450	x	Intership, Port operations and Ship movement.
10	156.500	156.500	x	Intership, Port operations and Ship movement. SAR, Pollution incidents, MSI broadcasts coordinated with HMCG.
11	156.550	156.550	x	Port operations and Ship movement.
12	156.600	156.600	x	Port operations and Ship movement.
13	156.650	156.650	x	Intership navigation safety (Bridge-to-bridge). International navigation safety channel. May also be used for ship movement, port operations and limited coast stations.
14	156.700	156.700	x	Port operations and Ship movement.
15	156.750	156.750	x	On-board communications. 1 watt maximum power.
16	156.800	156.800	x	International Distress, Safety and Calling.
17	156.850	156.850	x	On-board communications. 1 watt maximum power.
18	156.900	161.500		Public correspondence, Port operations and Ship movement.
19	156.950	161.550		Public correspondence, Port operations and Ship movement.
1019	156.950	156.950	x	Port operations and Ship movement.
2019	161.550	161.550	x	Port operations and Ship movement. Channel is limited to coast stations only unless otherwise permitted by UK regulation.
20	157.000	161.600		Public correspondence, Port operations and Ship movement.
1020	157.000	157.000	x	Public correspondence, Port operations and Ship movement.
2020	161.600	161.600	x	Public correspondence, Port operations and Ship movement. Channel is limited to coast stations only unless otherwise permitted by UK regulation.
21	157.050	161.650		Public correspondence, Port operations and Ship movement. Available for VDSMS
22	157.100	161.700		Public correspondence, Port operations and Ship movement. Available for VDSMS
23	157.150	161.750		Safety. HNCG – SAR and MSI broadcasts.
24	157.200	161.800		Public correspondence, Port operations and Ship movement. Available for VDSMS

CH No.	TX Freq	RX Freq (MHz)	Single Freq (MHz)	Use
1024	157.200	157.200	x	For future use
2024	161.800	161.800	x	For future use
25	157.250	161.850		Public correspondence, Port operations and Ship movement. Available for VDSMS
1025	157.250	157.250	x	For future use
2025	161.850	161.850	x	For future use
26	157.300	161.900		Public correspondence, Port operations and Ship movement. Available for VDSMS
1026	157.300	157.300	x	For future use
2026	161.900	161.900	x	For future use
27	157.350	161.950		Public correspondence, Port operations and Ship movement. Available for testing of new AIS applications.
1027	157.350	157.350	x	Port operations and Ship movement.
2027	161.950	161.950	x	Application specific message (ASM1)
28	157.400	162.000		Public correspondence, Port operations and Ship movement. Available for testing of new AIS applications.
1028	157.400	157.400	x	Port operations and Ship movement.
2028	162.00	162.00	x	Application specific message (ASM2)
60	156.025	160.625		Public correspondence, Port operations and Ship movement.
61	156.075	160.675		Public correspondence, Port operations and Ship movement.
62	156.125	160.725		Public correspondence, Port operations and Ship movement.
63	156.175	160.775		Public correspondence, Port operations and Ship movement.
64	156.225	160.825		Public correspondence, Port operations and Ship movement.
65	156.275	160.875		UK National Coastwatch.
66	156.325	160.925		Public correspondence, Port operations and Ship movement.
67	156.375	156.375	x	Intership, Port operations and Ship movement. HMCG — SAR and Safety.
68	156.425	156.425	x	Port operations and Ship movement.
69	156.475	156.475	x	Intership, Port operations and Ship movement.
71	156.575	156.575	x	Port operations and Ship movement.
72	156.625	156.625	x	Intership. Preferred intership channel.
73	156.675	156.675	x	Intership, Port operations and Ship movement. HMCG — SAR and MSI broadcasts.
74	156.725	156.725	x	Port operations and Ship movement.
75	156.775	156.775	x	Intership Navigation related communications only with 1 watt maximum power.
76	156.825	156.825	x	Intership Navigation related communications only with 1 watt maximum power.
77	156.875	156.875	x	Intership. Preferred intership channel.
78	156.925	161.525		Public correspondence, Port operations and Ship movement.
1078	156.925	156.925	x	Port operations and Ship movement.

CH No.	TX Freq	RX Freq (MHz)	Single Freq (MHz)	Use
2078	161.525	161.525	x	Port operations and Ship movement. Channel is limited to coast stations only unless otherwise permitted by UK regulation.
79	156.975	161.575		Public correspondence, Port operations and Ship movement.
1079	156.975	156.975	x	Port operations and Ship movement.
2079	161.575	161.575	x	Port operations and Ship movement. Channel is limited to coast stations only unless otherwise permitted by UK regulation.
80	157.025	161.625		Public correspondence, Port operations and Ship movement. Also marinas and yacht clubs UK only. Available for VDSMS.
81	157.075	161.675		Public correspondence, Port operations and Ship movement. Available for VDSMS
82	157.125	161.725		Public correspondence, Port operations and Ship movement. Available for VDSMS
83	157.175	161.775		Public correspondence, Port operations and Ship movement. Available for VDSMS
84	157.225	161.825		Port operations and Ship movement. HMCG — SAR and MSI broadcasts.
1084	157.225	157.225	x	For future use
2084	161.825	161.825	x	For future use
85	157.275	161.875		Public correspondence, Port operations and Ship movement. Available for VDSMS
1085	157.275	157.275	x	For future use
2085	161.875	161.875	x	For future use
86	157.325	161.925		Port operations and Ship movement. HMCG — SAR and MSI broadcasts.
1086	157.325	157.325	x	For future use
2086	161.925	161.925	x	For future use
87	157.375	157.375	x	Port operations and Ship movement. Available for testing of new AIS applications.
88	157.425	157.425	x	Port operations and Ship movement. Available for testing of new AIS applications.

Please be aware that:

- Intership channels are for communications between ship stations. Intership communications should be restricted to channels 6, 8, 72 and 77. If these are not available, the other channels marked for Intership may be used.
- Channel 70 is used exclusively for Digital Selective Calling (DSC) and is not available for regular voice communications.

Note:

1. Channel 06 may also be used for communications between ship stations and aircraft engaged in coordinated search and rescue operations. Ship stations should avoid harmful interference to such communications on channel 06 as well as to communications between aircraft stations, ice breakers and assisted ships during ice seasons.
2. Within the European Maritime Area and in Canada, channels 10, 67 and 73 may also be used by the individual administrations concerned for communication between ship stations, aircraft stations and participating land stations engaged in coordinated search and rescue and anti-pollution operations in local areas. Channel 10 or 73 (depending on location) are also used for the broadcast of Marine Safety Information by the Maritime and Coast Guard Agency in the UK only.
3. Channel 13 is designated for use on a worldwide basis as a navigation safety communication channel, primarily for intership navigation safety communications.

4. Channels 15 and 17 may also be used for on-board communications provided the effective radiated power does not exceed 1 Watt.
5. The use of channels 75 and 76 should be restricted to navigation related communications only and all precautions should be taken to avoid harmful interference to channel 16. Transmit power is limited to 1 Watt.

Private Channels (Europe only)

Country	Channel Designations	TX Freq	RX Freq	Channel Use
Belgium	96	162.425	162.425	Marina
Denmark	L1	155.500	155.500	Pleasure
	L2	155.525	155.525	Pleasure
Finland, Norway & Sweden	L1	155.500	155.500	Pleasure
	L2	155.525	155.525	Pleasure
	L3	155.650	155.650	Pleasure
Holland (Netherlands)	31	157.550	162.150	Marina
	37	157.850	157.850	Leisure
Denmark, Finland, Norway & Sweden	F1	155.625	155.625	Fishing
	F2	155.775	155.775	Fishing
	F3	155.825	155.825	Fishing
United Kingdom	M1	157.850	157.850	Marina
	M2	161.425	161.425	Marina

The national channels listed above have been allocated for the specific use within the countries listed. To use these channels you must have the appropriate license.

US Marine VHF Channels and Frequencies

Note:

Some of the channel numbers have recently changed. For completeness, both old and new numbers are shown in the table below.

(New) CH No.	(Old) CH No.	TX Freq (MHz)	RX Freq (MHz)	Single Freq	Use
1001	01A	156.050	156.050	x	Port operations and commercial, VTS. Available only in New Orleans / Lower Mississippi area.
1005	05A	156.250	156.250	x	Port operations or VTS in the Houston, New Orleans and Seattle areas.
06	06	156.300	156.300	x	Intership Safety.
1007	07A	156.350	156.350	x	Commercial. VDSMS.
08	08	156.400	156.400	x	Commercial (Intership only). VDSMS.
09	09	156.450	156.450	x	Boater calling. Commercial and Non-commercial. VDSMS.
10	10	156.500	156.500	x	Commercial. VDSMS.

(New) CH No.	(Old) CH No.	TX Freq (MHz)	RX Freq (MHz)	Single Freq	Use
11	11	156.550	156.55 0	x	Commercial. VTS in selected areas. VDSMS.
12	12	156.600	156.60 0	x	Port operations. VTS in selected areas.
13	13	156.650	156.65 0	x	Intership navigation safety (Bridge-to-bridge). Ships >20 metres in length maintain a listening watch on this channel in US waters.
14	14	156.700	156.700	x	Port operations. VTS in selected areas.
15	15	-	156.750	x	Environmental (Receive only). Used by Class 'C' EPIRBs.
16	16	156.800	156.80 0	x	International Distress, Safety and Calling. Ships required to carry radio, USCG, and most coast stations maintain a listening watch on this channel.
17	17	156.850	156.85 0	x	State Control.
1018	18A	156.900	156.90 0	x	Commercial. VDSMS.
1019	19A	156.950	156.95 0	x	Commercial. VDSMS.
20	20	157.000	161.600		Port operations (duplex).
1020	20A	157.000	157.00 0	x	Port operations.
1021	21A	157.050	157.050	x	US Coast Guard only.
1022	22A	157.100	157.100	x	Coast Guard Liaison and Maritime Safety Information Broadcasts. Broadcasts announced on channel 16.
1023	23A	157.150	157.150	x	US Coast Guard only.
24	24	157.200	161.800		Public correspondence (Marine operator).
25	25	157.250	161.850		Public correspondence (Marine operator).
26	26	157.300	161.900		Public correspondence (Marine operator).
27	27	157.350	161.950		Public correspondence (Marine operator).
28	28	157.400	162.00 0		Public correspondence (Marine operator).
1063	63A	156.175	156.175	x	Port operations and commercial VTS, Available only in New Orleans / Lower Mississippi area.
1065	65A	156.275	156.275	x	Port operations.
1066	66A	156.325	156.325	x	Port operations.
67	67	156.375	156.375	x	Commercial. Used for bridge-to-bridge communications in lower Mississippi river (Intership only).
68	68	156.425	156.425	x	Non-commercial. VDSMS.
69	69	156.475	156.475	x	Non-commercial. VDSMS.
71	71	156.575	156.575	x	Non-commercial. VDSMS.
72	72	156.625	156.62 5	x	Non-commercial (Intership only). VDSMS.

(New) CH No.	(Old) CH No.	TX Freq (MHz)	RX Freq (MHz)	Single Freq	Use
73	73	156.675	156.675	x	Port operations.
74	74	156.725	156.725	x	Port operations.
77	77	156.875	156.875	x	Port operations (Intership only).
1078	78A	156.925	156.925	x	Non-commercial. VDSMS.
1079	79A	156.975	156.975	x	Commercial. Non-commercial in Great Lakes only. VDSMS.
1080	80A	157.025	157.025	x	Commercial. Non-commercial in Great Lakes only. VDSMS.
1081	81A	157.075	157.075	x	US Government only – Environmental protection operations.
1082	82A	157.125	157.125	x	US Government only.
1083	83A	157.175	157.175	x	US Coast Guard only.
84	84	157.225	161.825		Public correspondence (Marine operator). VDSMS.
85	85	157.275	161.875		Public correspondence (Marine operator). VDSMS.
86	86	157.325	161.925		Public correspondence (Marine operator). VDSMS.
87	87	157.375	161.975		Public correspondence (Marine operator). VDSMS.
88	88	157.425	157.425		Commercial, Intership only. VDSMS.

Please be aware that:

- Recreational boaters normally use channels listed as Non-commercial: 68, 69, 71, 72 1078.
- Channel 70 is used exclusively for DSC and is not available for regular voice communications.
- Channels 75 and 76 are reserved as guards bands for channel 16 and are not available for regular voice communications.

Note:

1. Four digit channels indicate simplex use of the ship station transmit side of an international semi-duplex channel. Operations are different from that of international operations on that channel.
2. Channel 13 should be used to contact a ship when there is danger of collision. All ships of length 20 metres or greater are required to guard VHF channel 13, in addition to VHF channel 16, when operating within US territorial waters.
3. Channel 15 is receive only.
4. Channel 16 is used for calling other stations or for distress calls.
5. Channel 17 and channel 77 have a fixed power output of 1 watt.
6. Channel 13 and channel 67 have an initial power output of 1 watt. User can temporarily override this restrictions to transmit at high power.
7. VDSMS (VHF Digital Small Message Services). Transmissions of short digital messages in accordance with RTCM Standard 12301.1 is allowed.

WX Channels (North America only)

Weather Channel	Frequency in MHz
WX1	162.550
WX2	162.400

Weather Channel	Frequency in MHz
WX3	162.475
WX4	162.425
WX5	162.450
WX6	162.500
WX7	162.525
WX8	161.650
WX9	161.775
WX10	163.275

Canadian Marine VHF Channels and Frequencies

Note:

Some of the channel numbers have recently changed. For completeness, both old and new numbers are shown in the table below.

(New) CH No.	(Old) CH No.	TX Freq (MHz)	RX Freq (MHz)	Single Freq	Areas of operation	Use
01	01	156.050	160.650		BCC	Public correspondence.
02	02	156.100	160.700		BCC	Public correspondence.
03	03	156.150	160.750		BCC	Public correspondence.
1004	04A	156.200	156.200	x	BCC, EC	Intership, Ship/Shore, Commercial and Safety DFO / Canadian Coast Guard only in BCC area. Commercial fishing in EC area.
1005	05A	156.250	156.250	x	AC, BCC, EC, GL, NL, INLD BC, WC	Ship movement.
06	06	156.300	156.300	x	All areas	Intership, Commercial, Non-Commercial and Safety Maybe used for search and rescue communications between ships and aircraft.
1007	07A	156.350	156.350	x	AC, BCC, EC, GL, NL, INLD BC, WC	Intership, Ship/Shore and Commercial.
08	08	156.400	156.400	x	EC, INLD BC, WC	Intership, Commercial and Safety. Also assigned for Intership in the Lake Winnipeg area.
09	09	156.450	156.450	x	AC, INLD PRA, BCC	Intership, Ship/Shore, Commercial, Non-commercial, Safety and Ship movement. Commercial — BCC area. May be used to communicate with aircraft and helicopters in predominantly maritime support operations.

(New) CH No.	(Old) CH No.	TX Freq (MHz)	RX Freq (MHz)	Single Freq	Areas of op- eration	Use
10	10	156.50 0	156.50 0	x	AC, BCC, GL	Intership, Ship/Shore, Commercial, Non-commercial, Safety and Ship movement. Commercial — BCC area. May also be used for communications with aircraft engaged in coordinated search and rescue and antipollution operations.
11	11	156.55 0	156.55 0	x	AC, BCC, GL	Intership, Ship/Shore, Commercial, Non-commercial and Ship movement. VTS — BCC area. Also used for pilotage purposes.
12	12	156.60 0	156.60 0	x	AC, BCC, GL, WC	Intership, Ship/Shore, Commercial, Non-commercial and Ship movement. VTS — BCC area. Port operations and pilot information and messages.
13	13	156.65 0	156.65 0	x	AC, BCC, EC, GL, NL, INLD BC, WC	Intership, Commercial, Non-commercial and Ship movement. VTS — BCC area. Bridge-to-bridge navigational traffic.
14	14	156.70 0	156.70 0	x	AC, BCC, GL	Intership, Ship/Shore, Commercial, Non-commercial and Ship movement. VTS — BCC area. Port operations and pilot information and messages.
15	15	156.75 0	156.75 0	x	AC, BCC, EC, GL, NL, INLD BC, WC	Intership, Ship/Shore, Commercial, Non-commercial and Ship movement. Port operations and Ship movement — BCC area. All operations limited to 1 watt maximum power. May also be used for on-board communications.
16	16	156.80 0	156.80 0	x	All areas	International distress, safety and calling.
17	17	156.85 0	156.85 0	x	AC, BCC, EC, GL, NL, INLD BC, WC	Intership, Ship/Shore, Commercial, Non-commercial and Ship movement. Port operations and Ship movement — BCC area. All operations limited to 1 watt maximum power. May also be used for on-board communications.
1018	18A	156.90 0	156.90 0	x	AC, BCC, EC, GL, NL, INLD BC, WC	Intership, Ship/Shore and Commercial. Towing — BCC area.
1019	19A	156.95 0	156.95 0	x	All areas	Intership and Ship/Shore. DFO / Canadian Coast Guard. Pacific Pilots — BCC area.
20	20	157.00	161.60 0		AC, BCC, EC, GL, NL, INLD BC, WC	Ship/Shore, Safety and Ship movement. Port operations only with 1 watt maximum power.
1021	21A	157.05 0	157.05 0	x	All areas	Intership and Ship/Shore. DFO / Canadian Coast Guard only.
2021	21B	-	161.65 0	x	All areas	Safety Continuous Marine Broadcast (CMB) service.

(New) CH No.	(Old) CH No.	TX Freq (MHz)	RX Freq (MHz)	Single Freq	Areas of op- eration	Use
1022	22A	157.100	157.10 0	x	All areas	Intership, Ship/Shore, Commercial and Non-commercial. For communications between Canadian Coast Guard and non-Canadian Coast Guard stations only.
23	23	157.150	161.75 0		BCC, INLD BC	Ship/Shore and Public correspondence.
2023	-	-	161.75 0	x	GL	Safety Continuous Marine Broadcast (CMB) service.
24	24	157.20 0	161.80 0		All areas	Ship/Shore and Public correspondence.
25	25	157.25 0	161.85 0		BCC	Ship/Shore and Public correspondence.
2025	25B	-	161.85 0	x	AC	Safety Continuous Marine Broadcast (CMB) service.
26	26	157.30 0	161.90 0		All areas	Safety and Public correspondence.
27	27	157.35 0	161.95 0		AC, BCC, GL	Ship/Shore and Public correspondence.
28	28	157.40 0	162.00		BCC	Ship/Shore, Safety and Public correspondence.
2028	28B	-	162.00 0	x	AC, GL	Safety Continuous Marine Broadcast (CMB) service.
60	60	156.02 5	160.62 5		BCC	Ship/Shore and Public correspondence.
1061	61A	156.07 5	156.07 5	x	BCC	Intership, Ship/Shore and Commercial DFO / Canadian Coast Guard only in BCC area. Commercial fishing only in EC area.
1062	62A	156.125	156.12 5	x	BCC, EC	Intership, Ship/Shore and Commercial DFO / Canadian Coast Guard only in BCC area. Commercial fishing only in EC area.
1063		156.175	156.17 5	x	BCC	Intership, Ship/Shore and Commercial. Tow boats — BCC area.
64	64	156.22 5	160.82 5		BCC	Ship/Shore and Public correspondence.
1064	64A	156.22 5	156.22 5	x	EC	Intership, Ship/Shore and Commercial Commercial fishing only.
1065	65A	156.27 5	156.27 5	x	All areas	Intership, Ship/Shore, Safety, Commercial and Non-commercial. Search and rescue and antipollution operations on the Great Lakes. Towing on the Pacific coast. Port operations only in the St. Lawrence river area with 1 watt maximum power. Intership in INLD PRA area.
1066	66A	156.32 5	156.32 5	x	AC, BCC, EC, GL, NL, INLD BC, WC	Intership, Ship/Shore, Safety, Commercial and Non-commercial. Port operations only in the St. Lawrence river / Great Lakes areas with 1 watt maximum power. 1 watt marine channel in BCC area.

(New) CH No.	(Old) CH No.	TX Freq (MHz)	RX Freq (MHz)	Single Freq	Areas of op- eration	Use
67	67	156.37 5	156.37 5	x	All areas	Intership Ship/Shore, Safety, Commercial and Non-commercial. May also be used for communications with aircraft engaged in coordinated search and rescue and antipollution operations. Commercial fishing only in EC and INLD PRA areas. Pleasure craft — BCC area.
68	68	156.42 5	156.42 5	x	All areas	Intership, Ship/Shore and Non-commercial. For marinas, yacht clubs and pleasure craft.
69	69	156.47 5	156.47 5	x	AC, BCC, EC, GL, NL, INLD BC, WC	Intership, Ship/Shore, Commercial and Non-commercial. Commercial fishing only — EC area. Pleasure craft — BCC area.
71	71	156.57 5	156.57 5	x	AC, BCC, EC, GL, NL, INLD BC, WC	Intership, Ship/Shore, Safety, Commercial,, Non-commercial and Ship movement. Ship movement — BCC area. Marinas and yacht clubs — EC area and on Lake Winnipeg.
72	72	156.62 5	156.62 5	x	BCC, EC	Intership, Commercial and Non-commercial May be used to communicate with aircraft and helicopters in predominantly maritime support operations. Pleasure craft — BCC area.
73	73	156.67 5	156.67 5	x	All areas	Intership, Ship/Shore, Safety, Commercial and Non-commercial. May also be used for communications with aircraft engaged in coordinated search and rescue and antipollution operations. Commercial fishing only in EC and INLD PRA areas.
74	74	156.72 5	156.72 5	x	BCC, EC	Intership, Ship/Shore, Commercial, Non-commercial and Ship movement. VTS and Ship movement — BCC area.
75		156.77 5	156.77 5	x	All areas	Intership, Ship/Shore, Commercial and Ship movement. Simplex port operation, ship movement and navigation related communication only. 1 watt maximum power.
76		156.82 5	156.82 5	x	All areas	Intership, Ship/Shore, Commercial and Ship movement. Simplex port operation, ship movement and navigation related communication only. 1 watt maximum power.
77	77	156.87 5	156.87 5	x	AC, BCC, EC, GL, NL, INLD BC, WC	Intership, Ship/Shore, Safety and Ship movement. Pilotage BCC area, 25 watts. Port operations only in the St. Lawrence River/Great Lakes areas with 1 watt maximum power.
1078	78A	156.92 5	156.92 5	x	BCC, EC	Intership, Ship/Shore and Commercial. Fishing industry — BCC area.
1079	79A	156.97 5	156.97 5	x	BCC, EC	Intership, Ship/Shore and Commercial. Fishing industry — BCC area.
1080	80A	157.02 5	157.02 5	x	BCC, EC	Intership, Ship/Shore and Non-commercial. Whale watching — BCC area.

(New) CH No.	(Old) CH No.	TX Freq (MHz)	RX Freq (MHz)	Single Freq	Areas of op- eration	Use
1081	81A	157.07 5	157.07 5	x	AC, BCC, EC, GL, NL, INLD BC, WC	Intership, Ship/Shore and Safety. DFO / Canadian Coast Guard use only.
1082	82A	157.125	157.12 5	x	AC, BCC, EC, GL, NL, INLD BC, WC	Intership and Ship/Shore. DFO / Canadian Coast Guard use only.
1083	83A	157.175	157.17 5	x	BCC, EC	Intership and Ship/Shore DFO / Canadian Coast Guard and other government agencies.
2083	83B	-	161.77 5	x	AC, BCC, GL	Safety Continuous Marine Broadcast (CMB) service.
84	84	157.22 5	161.82 5		BCC	Ship/Shore and Public correspondence.
85	85	157.27 5	161.87 5		AC, BCC, GL ,NL	Ship/Shore and Public correspondence.
86	86	157.32 5	161.92 5		BCC	Ship/Shore and Public correspondence.
87	87	157.37 5	157.37 5	x	AC, BCC, GL, NL	Intership, Non-commercial and Ship movement. Port operation and ship movement — EC area. Pleasure craft — BCC area.
88	88	157.42 5	157.42 5	x	AC, BCC, GL, NL	Intership, Commercial and Ship movement. Port operation and ship movement — BCC area.

Area of operation:

- **AC** — Atlantic Coast, Gulf and St. Lawrence River up to and including Montreal.
- **BCC** — British Columbia Coast (Pacific Coast).
- **EC** — East Coast: includes NL, AC, GL and Eastern Arctic areas.
- **GL** — Great Lakes: includes St. Lawrence above Montreal.
- **NL** — Newfoundland and Labrador.
- **WC** — West Coast: includes BCC, Western Arctic and Athabasca-Mackenzie Watershed areas.
- **INLD BC** — Inland waters of BC and the Yukon
- **INLD PRA** — Inland waters of MB, SK and AB

Note:

1. Four digit channels indicate simplex use of the ship station transmit side of an international semi-duplex channel. Operations are different from that of international operations on that channel.
2. Channel 16 is used for calling other stations or for distress calls.
3. Channel 70 is used exclusively for Digital Selective Calling and is not available for regular voice communications.

Appendix E Phonetic alphabet

To help make call letters more clearly understood, and to assist in spelling out similar sounding or unfamiliar word, radiotelephone users employ the international phonetic alphabet.

A	ALPHA	N	NOVEMBER
B	BRAVO	O	OSCAR
C	CHARLIE	P	PAPA
D	DELTA	Q	QUEBEC
E	ECHO	R	ROMEO
F	FOXTROT	S	SIERRA
G	GOLF	T	TANGO
H	HOTEL	U	UNIFORM
I	INDIA	V	VICTOR
J	JULIET	W	WHISKEY
K	KILO	X	X-RAY
L	LIMA	Y	YANKEE
M	MIKE	Z	ZULU

Appendix F Prowords

Prowords can be used to simplify and speed up radio communications.

Proword	Meaning
ACKNOWLEDGE	Have you received and understood?
CONFIRM	Is that correct?
CORRECTION	An error has been made?
I SAY AGAIN	I repeat (e.g. important information).
I SPELL	Phonetically spelling of the word.
OUT	End of communication.
OVER	I have completed this part of the message and am inviting you to reply.
RECEIVED	Receipt acknowledgement.
SAY AGAIN	Repeat your message.
STATION CALLING	Used when a station is uncertain of the identity of a station which is calling.

Index

A

Accessories	176
AIS receiver	136
Applicable products	21
ATIS	
Enabling/Disabling	97, 135
Entering ID	96
ATIS ID	29

B

Backlight adjustment	87
Base station	
Power	78
Brightness	
Adjustment	87
Shared	88

C

Cable bend radius	54
Cable protection	54
Cable routing	34, 54
Call log	126
Details	126
Types	126
Checking password	107
Cleaning	146
Compass safe distance	34
Compatible MFDs	22
Connecting SeaTalkng® cables	65
Connections	57
Bare wires	55
Battery	58
DeviceNet	64
Distribution panel	59
General cabling guidance	54
GNSS antenna	68
GPS antenna	68
Loud hailer	67
NMEA 0183	66
NMEA 2000	64
Overview	56
Raymic handset	62
SeaTalkng	64
VHF antenna	68
Wire	55
Wired speaker	63
Wireless handset	72
Wireless hub	106
Wireless speaker	73, 108
Contact details	158
Contrast adjustment	87
Controls	
Raymic	76
Wired handset	76
Wireless handset	76

D

Dealer set-up	85
---------------------	----

DeviceNet cables	178
Diagnostics	
Base station	148
Wireless speaker	149
Digital Selective Calling, <i>See</i> DSC	
Dimensions	
Active speaker	40
Base station	39
Passive speaker	40
Raymic	41
Wired handset	41
Wireless hub	42
Display set-up	138
Distress call	112, 114
Cancelling	115–116
Making	114
Documentation	18
DSC set-up	128

E

Electromagnetic Compatibility	35
EMC	35

F

FCC ID	26
Fuse rating, Wireless speaker	71, 73

G

GNSS	
Antenna	21
Data output	154
Displayed data	100
Enabling/Disabling	100
Integrated	100
Internal	100
No position data	100
Position information	100
set-up	100
GPS, <i>See</i> GNSS	
Group call	123
Making	123
Receiving	123

H

Handset	
Power	78
Homescreen	79

I

IC ID	26
Individual call	113
Making	122
Reason codes	122
Receiving	122
Installation	
Best practice	61
EMC guidelines	35
surface requirements	34

Ventilation.....	34
VHF antenna requirements.....	35
Intercom	143
Interference	
Compass.....	34
Electrical	34
RF.....	34
ISED ID	26

L

LED	
Base station	148
Wireless speaker	149
Licensing	
Additional information.....	26
Europe and ROW Requirement	26
ISED Requirement.....	26
Requirement	26
USA Requirement	26
Location requirements	
GNSS	36
GPS.....	36
Wireless	37
Loud hailer.....	141

M

Maintenance.....	146
Making designated call	114
Manual position	100
Mayday call.....	115
Menus	
Dealer set-up	85
Display set-up	138
DSC set-up.....	128
Fog.....	140
Hailer	140
Intercom.....	140
Main menu	82
Set-up	137
Wireless set-up	109
MMSI.....	28
Entry.....	94
Where to apply	181
Mounting	
Base station	45
Pass-through panel kit.....	48
Raymic	47
Wired handset.....	47
Wired speaker	46
Wireless handset	51
Wireless hub	49
Wireless speaker	46
MPE	35
Multiple station operation.....	86

N

Network	
Selection.....	93
NMEA	
Settings	
Baud rate.....	93

NMEA 0183	
Sentences.....	179
NMEA 2000	
PGNs.....	180

P

Parts supplied.....	24
Phonebook.....	125
Adding entry	125
Deleting entry	125
Editing entry.....	125
Position request.....	124
Automatic response.....	124
Making	124
Responding.....	124
Power	57
Battery connection.....	58
Distribution	58
Distribution panel.....	59
Grounding.....	60
Sharing a breaker	59
Power cable extension	60
Product	
Documentation	18
Overview.....	20
Product support.....	158

R

Radio Frequency (RF) interference.....	34
Routine call, <i>See</i> Individual call	

S

Safety call	112
Making	121
Receiving	121
Scan mode	131
Setting.....	131
SeaTalkng cables.....	177
SeaTalkng documentation	18
SeaTalkng®	
Connecting cables.....	65
Securing cables.....	54
Service Center.....	158
Servicing.....	146
Set-up menu	137
Shared brightness	88
Software update	30
Raymic handset	31
Wired handset.....	31
Software version.....	30
Spares	174
Specification	
AIS Receiver	165
Battery	169
Charger.....	170
Connections.....	164
Environmental.....	164
GNSS (GPS).....	165
Power.....	164
Receiver.....	164
VHF Transmitter	164

Wired (Passive) speaker.....	167	Wireless menu.....	109
Wired handset (Raymic).....	166	Wireless set-up.....	109
Wireless (Active) speaker.....	171	Wireless speaker	
Wireless handset.....	169	Disconnecting.....	108
Wireless handset charging holster.....	170	Pairing.....	108
Wireless hub.....	168	WirelessPre-installation	
Status bar.....	80	Analyzer.....	38
Strain relief, <i>See</i> Cable protection		Site survey.....	38
Switching power output.....	99		

T

Technical specification.....	163
Base station.....	164
Technical support.....	158
Test call.....	127
Making.....	127
Receiving.....	127
Thermal breaker rating, Wireless	
speaker.....	71, 73
Transmit power.....	99
Troubleshooting.....	150
GNSS.....	154
GPS.....	154
Power.....	151

U

Urgency call.....	112
Making.....	120
Receiving.....	120

V

VHF antenna.....	21
VHF channels	
Canada.....	188
International.....	182
Private (Europe).....	185
United States.....	185
Weather (North America).....	187

W

Warranty.....	158
Watch mode.....	130
Dual watch.....	130
Setting.....	130
Triple watch.....	130
WEEE Directive.....	15
Wired components.....	21
Wireless	
Channel.....	38
Channel changing.....	107
Interference.....	37
Password changing.....	107
Wireless components.....	21
Wireless handset stations.....	104
Wireless hub.....	107
Antenna extension.....	50
Pairing.....	106
Password.....	106
Wireless hub settings.....	109