



Instruction Guide

Models 401C, 403C, 405C, 401STC, 403STC, 405STC, 401FC, 403FC, 405FC

Replacement motors 45DR, 46DR, 47DR

Tournament Series Livewell/Baitwell Pumps

Description

Powerful and long lasting, Rule Tournament Series Cartridge Pumps offer outstanding performance as well as the versatility of replacing the motor cartridge if the motor expires. The cartridge feature also allows complete access to the impeller for easy cleaning and maintenance. Replacing the motor cartridge only allows the fittings and hose to remain totally intact.

To Change Motor Cartridge

1. Block off the thru-hull before removing the motor cartridge
2. Disconnect wiring
3. Press cartridge button, twist counterclockwise and pull motor cartridge straight up
4. Reconnect wire to new motor cartridge
5. Align the arrows and press the new motor cartridge down firmly. Twist motor housing clockwise until cartridge locks in place

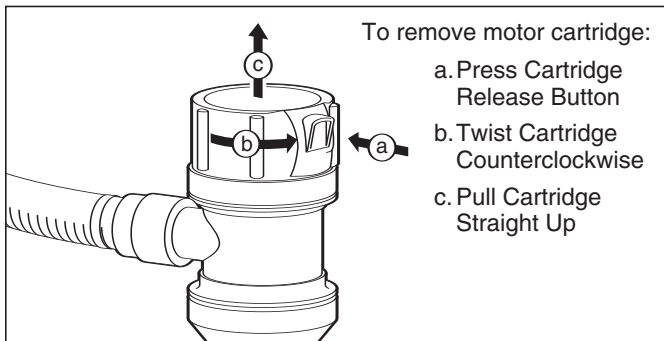

Dimensions in inches (mm)

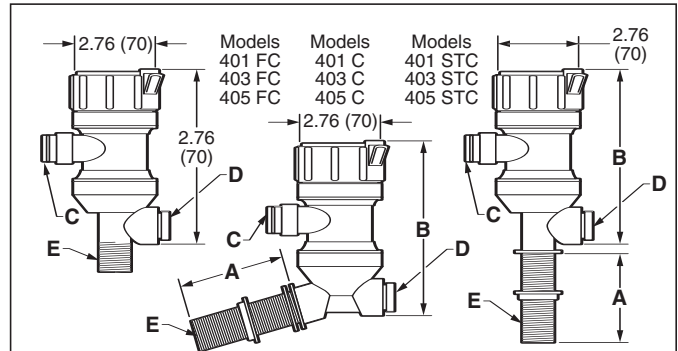

Model	A	B	C	D	E
401C	4.0 (102)	5.87 (149)	3/4-14NPSM	1/2-14NPT	3/4-14NPSM
403C	4.0 (102)	5.87 (149)	3/4-14NPSM	1/2-14NPT	3/4-14NPSM
405C	4.0 (102)	5.87 (149)	1-11.5NPSM	1/2-14NPT	3/4-14NPSM
401STC	4.33 (110)	5.84 (148)	3/4-14NPSM	1/2-14NPT	3/4-14NPSM
403STC	4.33 (110)	5.84 (148)	3/4-14NPSM	1/2-14NPT	3/4-14NPSM
405STC	4.33 (110)	5.84 (148)	1-11.5NPSM	1/2-14NPT	3/4-14NPSM
401FC		5.87 (149)	3/4-14NPSM	1/2-14NPT	3/4-14NPT
403FC		5.87 (149)	3/4-14NPSM	1/2-14NPT	3/4-14NPT
405FC		5.87 (149)	1-11.5NPSM	1/2-14NPT	3/4-14NPT

! WARNING This pump is designed for use with fresh and salt water. Use with any other medium, including particularly hazardous, caustic or corrosive substance, could result in damage to the pump, the surrounding environment and injury to persons or property, including possible exposure to hazardous substances. This pump is for water applications only.

Models

Model #	Description	Required Fuse Size (A)	GPH at Open Flow	GPH at 3.35 ft.
401 C	500 GPH Livewell Pump with Angled Pickup Tube	2.5	500	340
403 C	800 GPH Livewell Pump with Angled Pickup Tube	5	800	490
405 C	1000 GPH Livewell Pump with Angled Pickup Tube	6	1000	710
401STC	500 GPH Livewell Pump with Straight Pickup Tube	2.5	500	340
403STC	800 GPH Livewell Pump with Straight Pickup Tube	5	800	490
405STC	1100 GPH Livewell Pump with Straight Pickup Tube	6	1100	790
401 FC	500 GPH Livewell Pump with 1" Straight Pickup Tube	2.5	500	340
403 FC	800 GPH Livewell Pump with 1" Straight Pickup Tube	5	800	490
405 FC	1100 GPH Livewell Pump with 1" Straight Pickup Tube	6	1100	790

Replacement Motors

45DR	500 GPH Replacement Motor	2.5	500	340
46DR	800 GPH Replacement Motor	5	800	490
47DR	1000 GPH Replacement Motor	6	1100	790

Mounting the Pump (Models 401C, 403C, 405C, 401STC, 403STC 405STC)

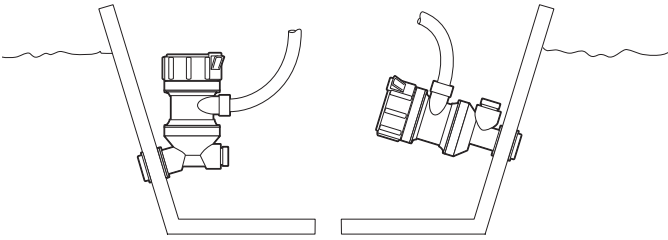

1. Drill a 1" diameter hole through the transom or hull bottom. If drilling through the transom, make sure the hole inside the boat is beneath the waterline outside the boat when the boat is standing still.
2. Place the pump into the hole with the gasket in place on the inside of the boat.
3. Tighten the nut on the outside of the hull until you are sure the gasket ring is tightly sealed. Be careful not to over-tighten. Make sure outlet is at least parallel with boat bottom. This helps prevent airlocks.
4. Saw off the excess length of the pickup tube so it is flush with the outside surface of the nut. In the event you are using a strainer (Rule Model 73), leave 1/2" beyond the nut. Make sure the cut is square and the threads deburred to allow the debris strainer to fit smoothly.

By lifting the locking ring, you can rotate the position of the discharge nozzle so that the discharge is facing toward the tank (see diagram below).

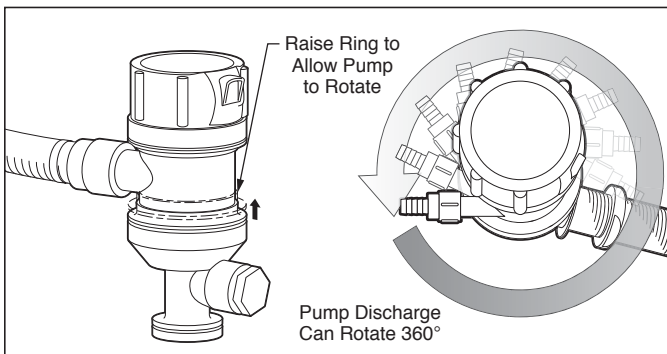

(Models 401FC, 403FC 405FC) Seacock applications

1. Drill a 1" diameter hole through the transom or hull bottom. If drilling through the transom, make sure the hole inside the boat is beneath the waterline outside the boat when the boat is standing still.

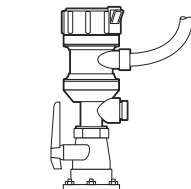

2. Install a thru-hull pickup tube with a filter grate to prevent debris from entering the seacock and the pump. Use a marine sealant on the flat surface of the thru-hull where it will be in contact with the outside surface of the boat and around the threaded tube on both sides of the hull. Install the seacock and pump using pipe tape or sealant on all threaded connections.
3. Screw the pump into the seacock until it is hand tight. Do not over-tighten.
4. If the pump is mounted horizontally, the output must be pointed upward to allow air to vent.

KEEP SEACOCK VALVE CLOSED WHEN LIVWELL IS NOT IN USE

Electrical

WIRE: Normal installations require 16 gauge wire.

POLARITY: Brown pump wire connects to the positive (+) side of the battery. Black pump wire connects to the negative (-) side of the battery.

FUSE: Install proper size fuse & holder in the positive (+) brown wire between the pump and the battery.

500 GPH pumps (Models 401C, 401STC, 401FC) -
INSTALL A 2.5 AMP FUSE

800 GPH pumps (Models 403C, 403STC, 403FC) -
INSTALL A 5.0 AMP FUSE

1100 GPH pumps (Models 405C, 405STC, 405FC) -
INSTALL A 6.0 AMP FUSE

IMPORTANT - THIS PRODUCT SHOULD BE INSTALLED WITH THE RECOMMENDED FUSE SIZE

NOTE: Keep all wire connections and joints above highest possible water level.

Seal wire connections with a marine sealant to prevent corrosion.

Hose Connection

Dual Port Option

Each pump is fitted with an additional 1/2" NPT female port and Hex Plug. This feature allows you to add your washdown pump without adding another thru-hull fitting.

- Use a marine ribbed hose that will not kink with bends and is rated for below water line use.
- Hose should run uphill evenly from pump to livewell tank. You may use a control valve to regulate the flow.
- Use hose clamps when making connections to pump and valve.

