





Tools Required		Hole Saw ø50-52mm (2")
		Power drill
		ø8.5mm (21/64") Drill Bit
		5mm Allen Key
		10mm Spanner

Parts Required		M8 Fasteners	x4
		- M8 x 25mm+ - 8mm Plain Washer	

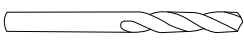

CAM-PT-150/300-02

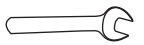
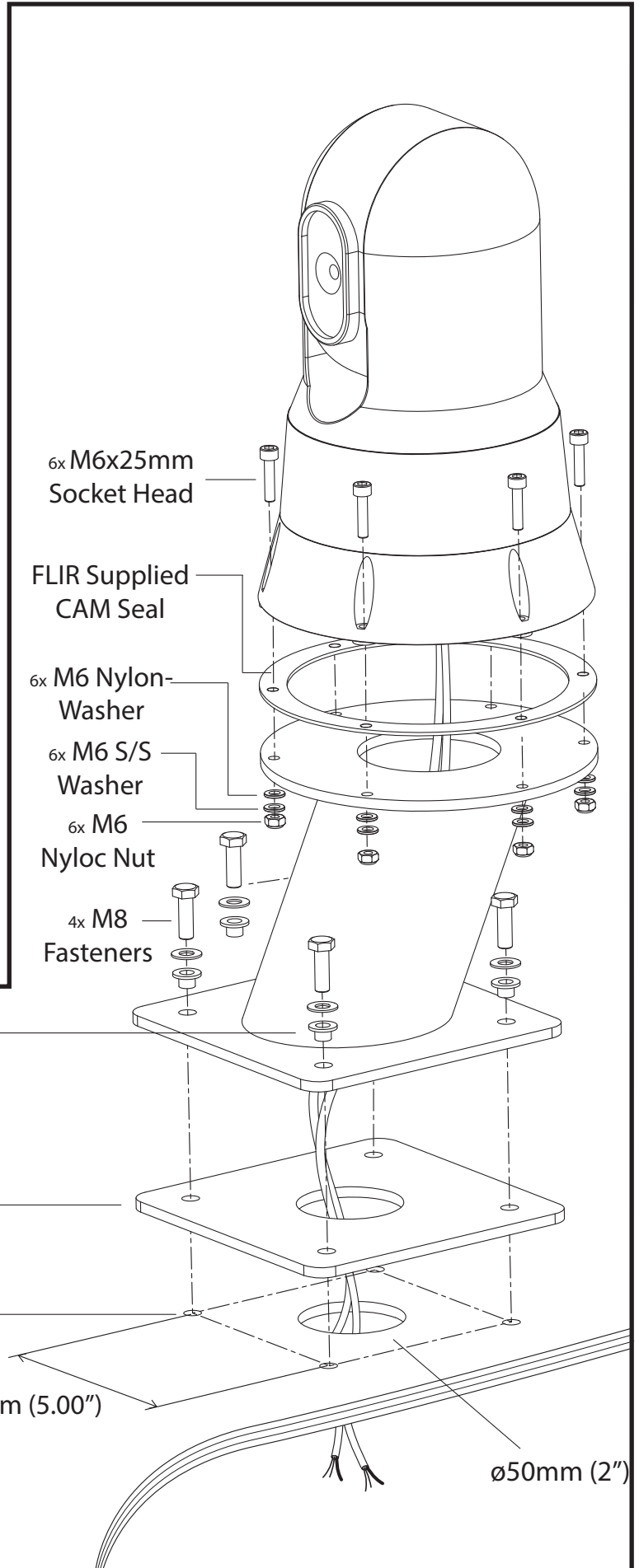
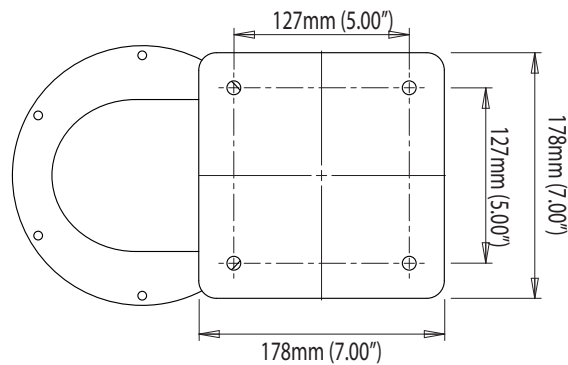
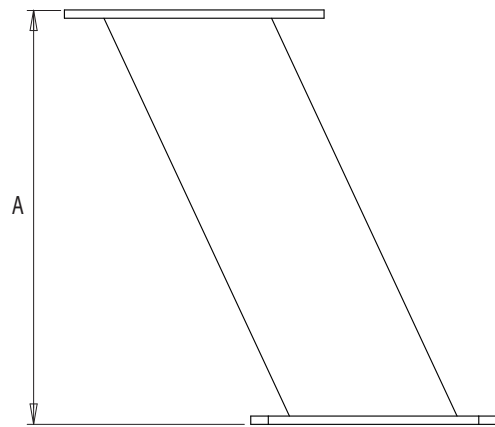
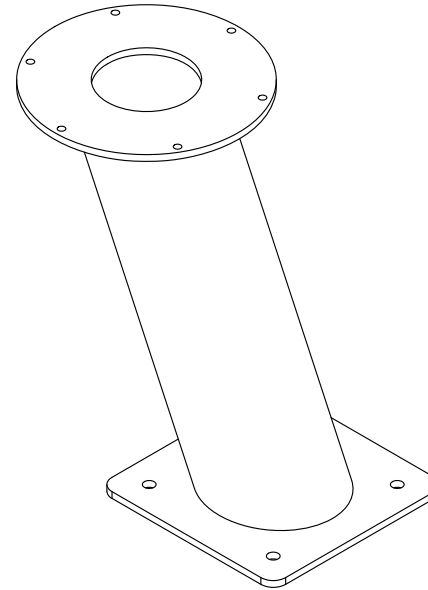
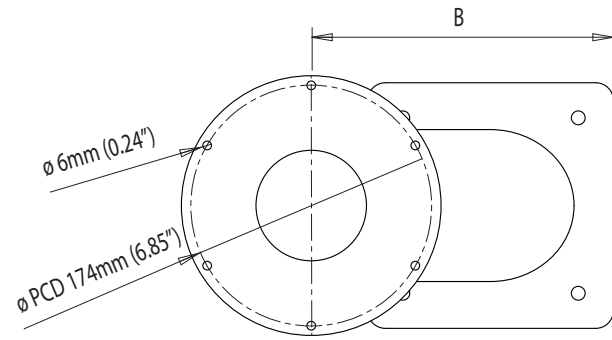

	A mm / inches	B mm / inches
CAM-PT-150-02	150/5.91	149/5.87
CAM-PT-300-02	300/11.81	219/8.62



SCANSTRUT