

HOURMETER INSTALLATION AND WIRING INSTRUCTIONS

1530/1531 /1532

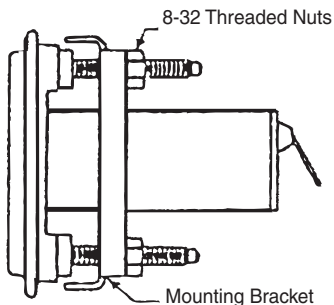

Figure 1

Warning: Do Not Allow Wiring Terminals To Touch Each Other

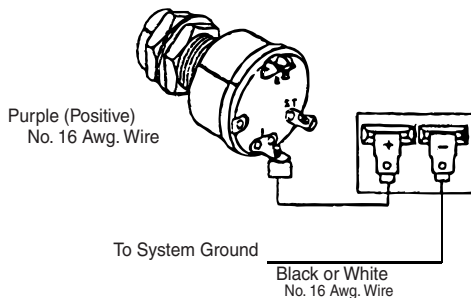

Figure 2

Installer: These instructions contain important information and must be forwarded to the boat owner SEACHOICE PRODUCTS.

CAUTION

Read these instructions before proceeding with installation.

Do not deviate from wiring instructions. Incorrect wiring could cause electrical short and possible fire. Always disconnect positive lead from battery before making any electrical connections.

INSTALLATION

Model 15301 and 15311

1. If no hole exists cut a 2" (5.08cm) diameter hole through panel.
2. Insert Gauge into mounting hole. Fit bracket over mounting studs on back of gauge (See Figure 1).
3. Install a nut and washer into mounting studs as shown in Figure 1.

CAUTION: Over torquing of nut may crack gauge housing or mounting panel.

Model 15321

1. If no hole exists, cut a 1-3/8" x 7/8" (3.49cm x 2.22 cm) hole through panel
2. Insert Gauge into mounting hole. Use 2 #8 screws to mount.

ADDITIONAL EQUIPMENT NEEDED TO COMPLETE INSTALLATION:

- No. 16 stranded insulated wire.
- Insulated terminal lugs as required.

CONNECTION OF WIRING

Connect Wire to Gauge Terminals

1. Using Purple wire, run a lead from '+' (ignition) terminal of gauge to 'IGN' terminal of ignition switch (See Figure 2).
2. Using either black or white wire, run a lead from '-' (ground) terminal of gauge to electrical system Ground.
3. When system wiring is complete, connect power and check gauge for proper operation. The hourmeter will advance the right hand digit every six minutes (1/10 Hour). Hourmeter should not advance when ignition switch is off.