

4" to 27" TANK DEPTH FUEL SENDER

SEACHOICE
PRODUCTS

The Quality
Choice

FOR MODELS 15421

Instructions for installation of a fuel level sending unit into fuel tanks designed to accept such units.

CAUTION

GASOLINE IS EXTREMELY FLAMMABLE. KEEP SPARKS AND FLAME AWAY FROM TANK AREA. PURGE TANK OF FUEL AND FUMES BEFORE PROCEEDING.

READ THESE INSTRUCTIONS THOROUGHLY BEFORE PROCEEDING WITH INSTALLATION. DO NOT DEVIATE FROM WIRING INSTRUCTIONS.

INCORRECT WIRING COULD CAUSE ELECTRICAL SHORT AND POSSIBLE FIRE. ALWAYS DISCONNECT BATTERY BEFORE MAKING ANY ELECTRICAL CONNECTIONS.

PREPARATION FOR INSTALLATION

1. If tank is equipped with a sender, remove it and note float arm position. Note that the screw hole patterns in the mounting plate and the top of the tank are not symmetrical. This allows repositioning of the float arm relative to the mounting holes every 90°.
2. If rotation of the sending unit is necessary for your installation, loosen brass nut at top of sending unit enough so the mounting plate can be raised approximately 1/8" (3mm) to clear the square.
3. Rotate the sending unit and brass screw assembly in 90° increments to insure clearance of the float arm with the tank or baffle wall.
4. Torque brass nut to 15 in. lb. (1.7 Nm) using torque wrench.

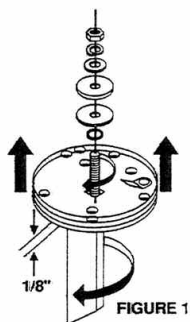

ADJUSTING FLOAT ARM LENGTH

1. Determine tank depth by measuring from inside bottom to outside top of tank, minus 1/2". Refer to Figure 2.
2. Assemble float arm to sending unit with float arm clamp. Refer to Figure 3.
3. Measure from underside of mounting plate to bottom of float. Adjust float arm clamp to desired tank depth, mark and cut excess rod length.

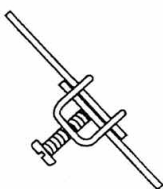
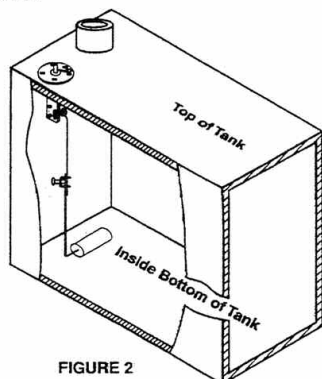

SENDING UNIT INSTALLATION INTO THE TANK

1. Carefully slide gasket over float arm and sending unit to fit flat against underside of mounting plate. Install completed unit into tank by carefully inserting float arm and then sender through the tank hole. Avoid bending float arm, as this may cause the sending unit to give improper readings.

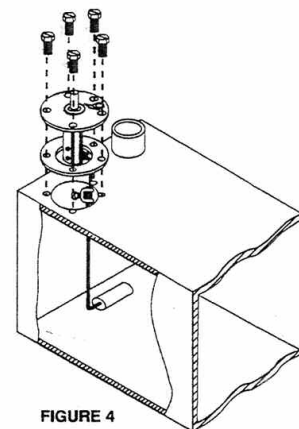

FIGURE 4

Make sure the gasket aligns properly with the mounting plate and the tank. The five hole screw pattern will only fit one way, as shown in Figure 4.

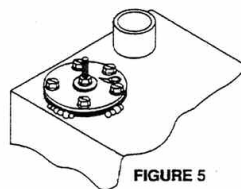

FIGURE 5

2. Screws should be hand tightened and a leak test (Figure 5) of this area should be performed to ensure no leaks. If uncertain how to perform any of the above procedures or are unsure of electrical wiring connections, seek the services of a qualified individual.

3. Using No. 18 wire and ring terminal, run a lead from screw on the top of sender to "S" terminal of fuel gauge (not included with this kit).

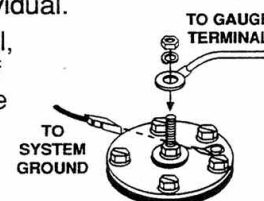

FIGURE 6

CAUTION

SENDING UNIT MUST BE GROUNDED USING NO. 16 WIRE AND 1/4 PUSH-ON TERMINAL. RUN A LEAD FROM THE TERMINAL ON THE MOUNTING PLATE TO ELECTRICAL SYSTEM GROUND. REFER TO FIGURE 6.

BEFORE RECONNECTING BATTERY TO ELECTRICAL SYSTEM, RECHECK WIRING TO ENSURE ALL CONNECTORS ARE PROPERLY MADE. INCORRECT CONNECTIONS OR ELECTRICAL SHORTS COULD CAUSE DAMAGE OR FIRE IN SYSTEM.

ELEMENTS OF ELECTRICAL SYSTEM SHOULD HAVE PROPER FUSES INSTALLED.