

English SEACHOICE SOLID STATE ELECTRONIC FUEL PUMP INSTALLATION INSTRUCTIONS

The SEACHOICE Solid State Electronic Fuel Pump is designed to replace the original equipment fuel pump on carburetor-equipped cars, trucks, agricultural equipment, marine pleasure craft, and generators. The solid-state design provides greater reliability, longer life, easy installation, freedom from hot weather vapor lock, and faster engine starting in cold weather. When properly installed, your fuel pump will provide a consistent, steady fuel supply to keep your vehicle running smoothly for many years to come even under severe driving conditions.

OPTIONAL ITEMS:

- 2 – 5/16-inch fuel line fittings
- 2 – 1/4-inch Hex self-tap screws
- 2 – 1/4-inch nuts
- 2 – 1/4-inch star washers

REQUIRED ITEMS:

- 1 – In-line fuel filter (74 micron) to be mounted on the pump's inlet port.
- 2 – Pump must be properly fused with a 3- to 5-Amp automotive-type fuse.

SUGGESTED TOOLS: Electric drill & 7/32-inch bit, tube cutter, hose clamp pliers, locking pliers,

7/16-inch wrench & fuel line plugs, hose clamps, wiring connectors, wire, 5/16-inch flex-hose.

PREPARATION

- 1 – Needed: (ABC) fire extinguisher within reach.
- 2 – Disconnect the vehicle battery, relieve fuel line pressure, then disconnect fuel line.
- 3 – Select mounting area where temperature won't exceed 140°F (60°C).
- 4 – Ensure the fuel pump electrical requirements match those of the vehicle electrical system.

OPTIONAL

Install an OIL PRESSURE SAFETY SWITCH during installation of this fuel pump and connect the **Red** power lead to the **P** contact. This stops pump operation if the engine stops and the ignition switch is **ON**. (Fig. 1)

INSTALLATION

NEGATIVE GROUND SYSTEM ONLY

- 1 – Select mounting location: a clean section of the frame away from an area susceptible to road hazard damage, exhaust systems, and must be within (12) vertical inches from the fuel tank (bottom).
- 2 – Position the pump in an upward direction at 45° away from the tank. Mark and drill (2)

- 3 – Place the pump over the holes and start the first 1/4-inch self-tap screw into the frame. Start the second screw capturing the black (neg) lead into the other hole. Tighten both screws.

NOTE: Some installations may require fastening the bracket to threaded studs with 1/4-inch nuts.

- 4 – Install the fuel filter (74 micron) on the inlet. Reconnect fuel line and clean up spilled fuel.
- 5 – Connect the RED (positive) power lead to the OIL PRESSURE SAFETY SWITCH OR TO A RELAY CONTROLLED BY IGNITION. If this pressure switch is not available, connect to the ignition switch voltage supply terminal.
- 6 – Reconnect the battery terminals.
- 7 – Turn ignition switch to ON, and start engine. Observe the pump is operating by hearing a vibrating sound from it. Ensure there are no leaks in the fuel system.

Solid State Electronic Fuel Pump

POS AND NEG GROUND SYSTEM

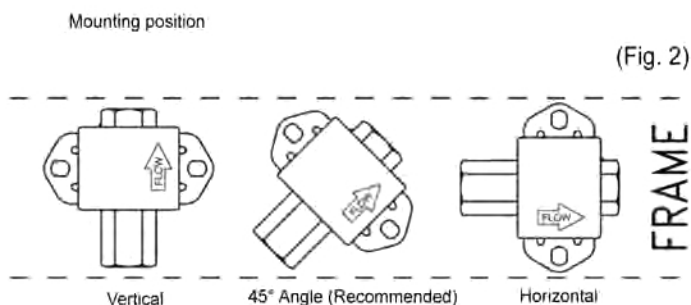
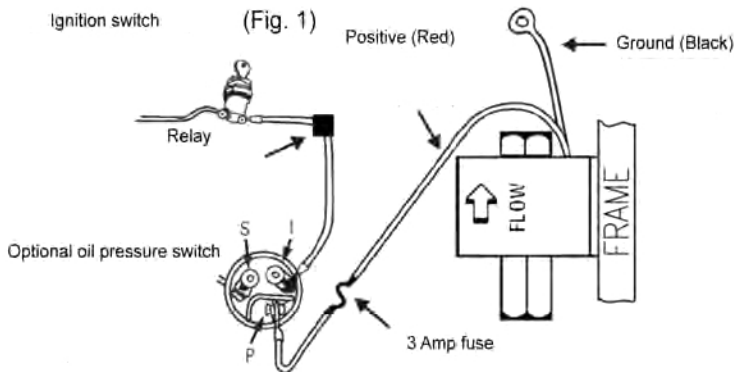

Note: Torque in-line fuel filter/ fitting to 10-15 ft. lbs.

