



SHERWOOD[®]

Maintenance & Repair Manual

2 0 0 9 - 2 0 1 0



A COMPLETE GUIDE TO RUBBER IMPELLER PUMP IDENTIFICATION & REPAIRS

The First 100 Years

The seawater pump is the heart of the marine engine, supplying a continuous flow of raw water to maintain temperatures consistent with the demanding engine performance. Over the years, Sherwood seawater pumps have developed a reputation of excellence in quality; and today are chosen for their performance and dependability by the most prestigious marine engine manufacturers.

In the beginning, dating back to 1903, William Sherwood and his friend and business partner David Buick (of General Motors fame) operated a copper brass plumbing business. They parted ways as Buick became more interested in the automobile. Sherwood then developed the plumbing accessories and beer equipment business into a foundry and machine shop, as Sherwood was sought out by Ford, the Dodge brothers, and others for the expanding auto-driven industries in Detroit, Michigan.

In the 1920s, Chris Smith helped create the inboard-powered pleasure boat industry by combining automobile engines and boat hulls to increase speed with greater detail, style and comfort. His company (Chris-Craft) incorporated William Sherwood's expertise of plumbing and custom manufacturing as they developed the first seawater pumps for marine inboard engines.

The commitment in the marine field continued with the next generation of Sherwood. World War II furthered this commitment, as Sherwood became a prime supplier of Marine Engine Coolant Pumps for the United States Navy. On June 6th, 1944, a Chris-Craft built personnel carrier with a Sherwood pump was the first allied Landing Craft to hit the Normandy beaches. During this time, Sherwood also supplied pumps to marine engines of Buda, Caterpillar, Cummins, Gray, Hercules and Packard.

With the advance of pleasure boating after WWII, activities were turned to accommodating the exacting cooling pump needs of this growing market. Sherwood kept pace with the new engines from GM, Chrysler and Ford by continuing, expanding and developing relationships with Chris-Craft, Chrysler Marine, Crusader, Escort Marine, OMC and Pleasurecraft Marine.

In the 1970s, Sherwood joined Hypro and continued its focus on pump and pump-related manufacturing. Today, the Sherwood brand has taken the history of quality designs and manufacturing to become the seawater pump of choice for new marine Diesel and Gasoline engines. Sherwood services customers throughout the world with the help of the marine industry's leading engine manufacturers, independent distributors, and dealers – as well as with direct manufacturing, regional sales, and distribution facilities in Minnesota, Illinois, California and the United Kingdom.

Table of Contents

	Page
Pumps	4
Engine Specified Pumps	
General Service Pumps	
Impellers	10
Performance	
Identification	
Kit Information	
Accessories	14
Strainers and Brackets	
Service Section	15
Pumps by Engine Manufacturer	
Other OEM and General Service Pumps	
Technical Guides	30
G Series	
R Series	
P Series	
17000 Series	
18000 Series	
22000 Series	
26000 Series	
Preventative Maintenance and Inspection	47

Engine Specified Pumps

Model G20, G21
(See pages 22-23, 30-32)



Model G30-2, G30-2B, G45-1
Chris Craft 350 & 454
(See pages 16-17, 30-32)



Model R991
Yamaha
(See pages 24-25)



Model G9901
OMC/Volvo 4.3-8.2
(See pages 22-25, 30-32)



Model G9903
Volvo/OMC 3.0-8.2
(See pages 22-25, 30-32)



Model D55, D60, D65, D75
Chrysler M225-M440
(See pages 18-19)



Model N10360GX
Chris Craft 283
(See pages 16-17)



Model E35
(See pages 18-19, 33-34)



Model G5, G7, G7B, G50
Chrysler 318-340
(See pages 18-19, 30-32)



The #1 Reason for Premature Engine Wear Is Overheating. To Maintain...

Model P101, P1012, P1014
 (See pages 28-29, 35-36)

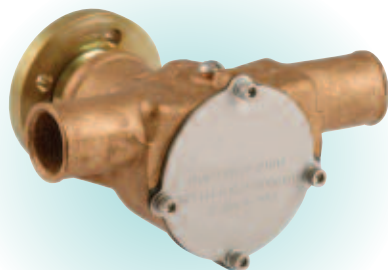

Model P105
 (See pages 28-29)



Model P109, P110
 (See pages 28-29)

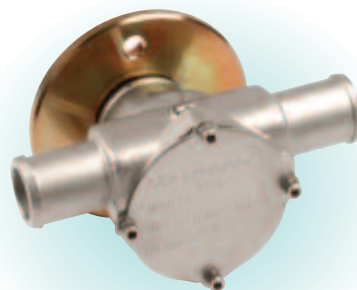

Model G55-2
 (See pages 22-23, 30-32)



Model G155
 Marine Corp/Star Power
 (See pages 22-23, 30-32)



Model G151
 Marine Corp/Star Power
 (See pages 20-23, 30-32)



Model G8001
 (See pages 26-27)

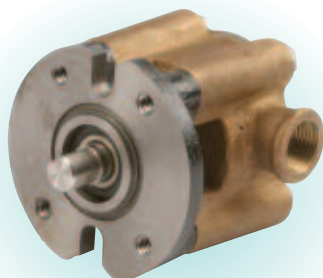

Model G8002
 (See pages 26-27)



Model R30G, R30G-1
 (See pages 24-29, 33-34)



...Engine Performance, Insist Upon Original Engine Specified Sherwood Products.

Engine Specified Pumps

Model G701, G702
(See pages 26-27)



Model G906, G907
(See pages 20-21)



Model G907P
(See pages 26-27)



Model G903, G908
(See pages 24-25)



Model K75B, L10B
(See pages 20-21, 30-32)



Model G1006, G1008
(See pages 26-27)



Model R50G, R10870G
(See pages 24-29, 33-34)

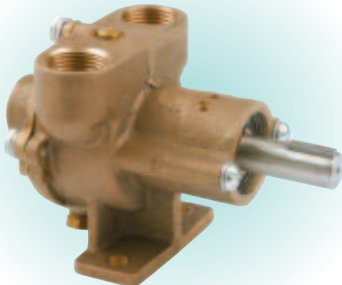

Model H5
Perkins
(See pages 22-23)



Model G65
Perkins
(See pages 22-23)



The #1 Reason for Premature Engine Wear Is Overheating. To Maintain...

Model M71
(See pages 28-29, 30-32)

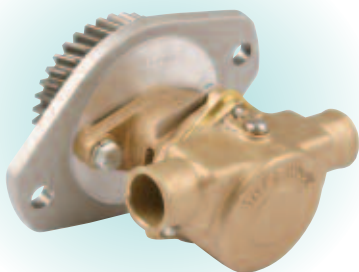

Model P1016
(See pages 28-29, 35-36)



Model RPBC
Perkins
(See pages 22-23)



Model GC1, GC4, GC5
(See pages 26-29, 30-32)

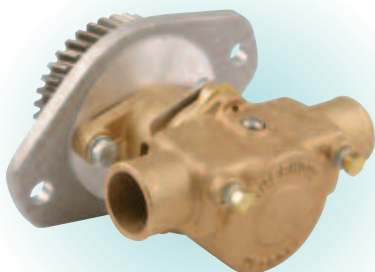

Model P176
(See pages 28-29, 37-38)



Model P1710, P1726, P1732
(See pages 28-29, 37-38)



Model P1711, P1719, P1733
(See pages 28-29, 37-38)

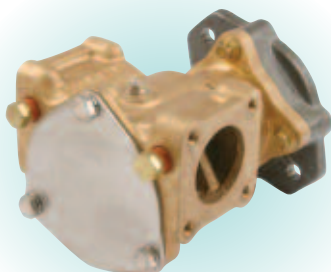

Model P1716, P1722, P173
(See pages 28-29, 37-38)



Model P1727, P1730, P1731
(See pages 28-29, 37-38)



...Engine Performance, Insist Upon Original Engine Specified Sherwood Products.

**Model P2701, P2702, P2704,
P2705, P2706, P2701X**
(See pages 28-29, 37-38)

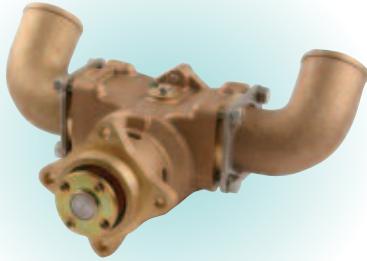

**Model G2601, G2601X,
G2603, G2605**
(See pages 26-27, 44-46)



Model G2602
(See pages 26-27, 44-46)



Model G1801, G1805
(See pages 26-27, 39-41)

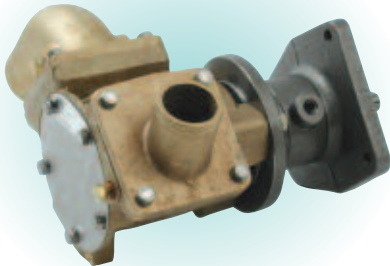

Model G1806, G18061
(See pages 26-27, 39-41)



**Model G1807,
G18071, G18072, G18071X**
(See pages 26-27, 39-41)



**Model G1808,
G18081, G18082, G18082X**
(See pages 26-27, 39-41)



**Model G1810, G1811,
G1814, G1814X, G1810X**
(See pages 26-27, 39-41)



**Model G22012X,
G22011, G22012**
(See pages 26-27, 42-43)

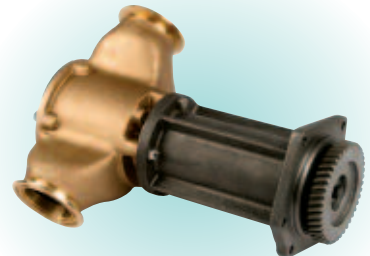

General Service Pumps



Horizontal Porting G1 & G3



Vertical Porting G2, G4, & G11

G Series

- Mechanical Seal
- Bronze Housing
- Stainless Steel Shaft
- Sealed Ball Bearing
- Excellent for Engine Cooling, Either as Replacement for Obsolete Pump or New Installation

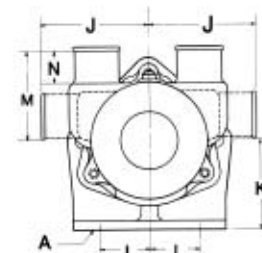
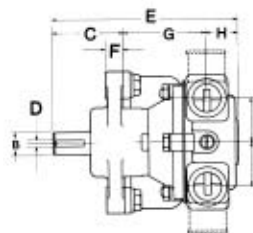
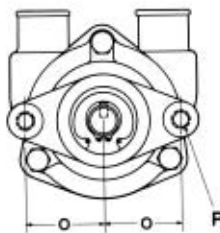

Model No.	Impeller	Port Size	Dimensions (Inches)															
			A	B	C	D	E	F	G	H	I	J	K	L	M	N	O	P
G1	09959	1" Hose	13/32	5/8	2-1/64	3/16	5-1/4	1/2	2-25/64	27/32	1-1/4	2-5/8	2-1/8	1-3/8	-	7/8	1-5/8	3/8
G2	09959	1" Hose	13/32	5/8	2-1/64	3/16	5-1/4	1/2	2-25/64	27/32	1-1/4	-	2-1/8	1-3/8	2-1/4	7/8	1-5/8	3/8
G3	10615	1-1/4" Hose	13/32	5/8	2-1/64	3/16	5-5/8	1/2	2-37/64	1-1/32	1-1/2	2-5/8	2-1/8	1-3/8	-	7/8	1-5/8	3/8
G4	10615	1-1/4" Hose	13/32	5/8	2-1/64	3/16	5-5/8	1/2	2-37/64	1-1/32	1-1/2	-	2-1/8	1-3/8	2-5/16	7/8	1-5/8	3/8
G11	09000	1/2" NPT	13/32	5/8	2-1/64	3/16	5-1/4	1/2	2-25/64	27/32	1-1/4	-	2-1/8	1-3/8	2-1/4	7/8	1-5/8	3/8

• See Impeller Flow Curves on Page 10 for Performance.



R Series

- Heavy Duty Design for Pulley Drive or Long Couple
- Mechanical Seal for Extended Seal Life
- Rear Support Bushing for Load Absorption
- Ball Bearing Supported Drive Shaft
- Corrosion Resistant Bronze Constructed
- Neoprene Impeller and Buna Seal - Standard
- Stainless Steel Shaft

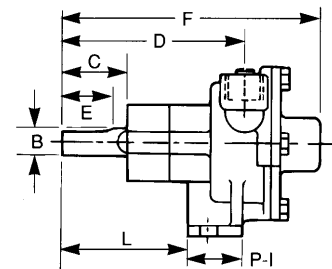
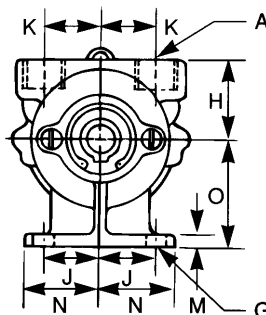

Model No.	Impeller	Port Size	Dimensions (Inches)															
			B	C	D	E	F	G	H	I	J	K	L	M	N	O	P	
R30G	10077	1/2" NPT	.50	1.50	3.56	1.0	5.28	.34	1.47	.75	1.06	1.12	3.09	.25	1.44	1.38	.44	
R50G	09959	3/4" NPT	.63	1.50	4.06	1.0	5.28	.41	1.63	.75	1.12	1.25	3.34	.25	1.50	2.12	.50	
R102	10615	1" NPT	.63	1.50	4.53	1.0	6.66	.41	2.12	.88	1.38	1.50	3.97	.25	1.81	2.12	.56	

• Recommended Horsepower: R30G - 1/2, R50G - 3/4, R102 - 2. See Impeller Flow Curves on page 10 for Performance.

Impeller Performance

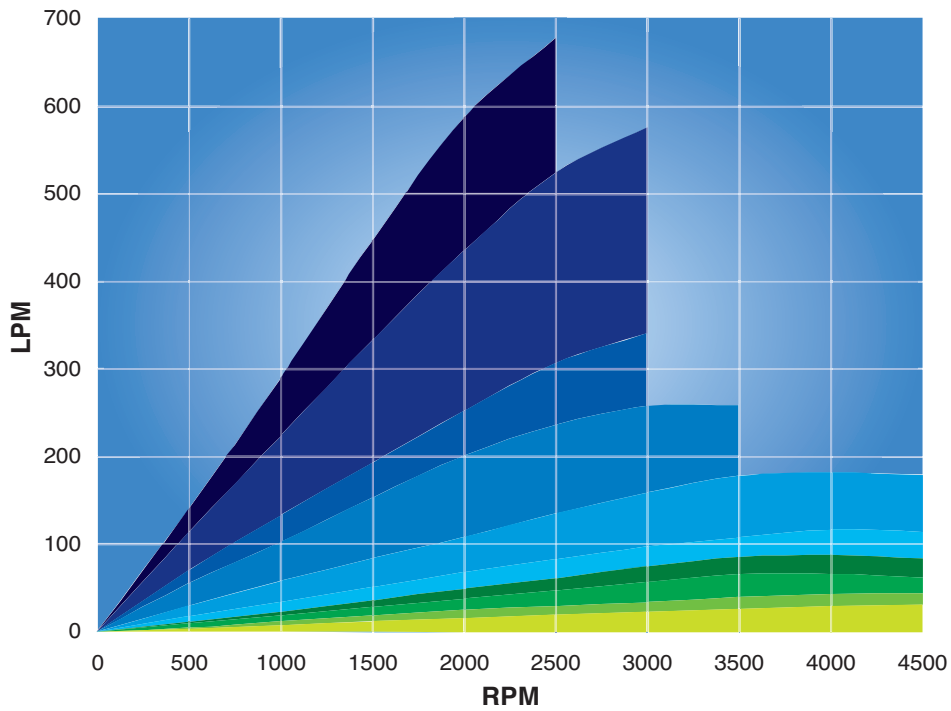

- 08000 Impeller
- 10077 Impeller
- 09000 Impeller
- 09959 Impeller
- 10615 Impeller
- 15000 Impeller
- 17000 Impeller
- 26000 Impeller
- 18000 Impeller
- 22000 Impeller

Genuine Sherwood Impellers & Impeller Kits

Patented Impeller Puller

17000A, 18000, 22000, 26000, 27000 impellers contain a patented threaded insert design. Patent No. 6,116,855. (Additional patent pending for the 17000A)

23631 Puller used for:

17000A, 18000, 22000, 26000

24412 Puller used for:

27000

Impeller Kits Include:

All Gaskets, O-rings, new Technical Service Guide and Engine Specified Impeller for up to 50 Sherwood pumps.

Impeller Kits Available:

- | | |
|--------|--------|
| 08000K | 17000K |
| 09000K | 18000K |
| 10077K | 22000K |
| 09959K | 26000K |
| 10615K | 27000K |
| 15000K | |

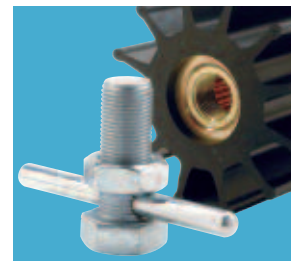

Impeller Removal and Installation

Threaded Impellers

(17000A*, 18000, 22000, 26000, and 27000). Patent No. 6,116,855.

*17000A standard impeller in 17000K is threaded/thru-key design (**Patent Pending**).

Removal

- Remove the cover.
- Insert the Sherwood puller into the threaded insert.
- Screw the puller against the shaft, lifting the impeller out of the housing or until loose.
- Twist and pull the impeller out of the pump.

Installation

- Apply a non-petroleum based lubricant to impeller (i.e. silicone or soapy water).
- Install the impeller with a twisting motion onto the shaft.
- Option: Use puller tool to push impeller into pump by loosening and lowering nut until tightens against impeller insert, then turning for installation.
- Then use a small amount of non-petroleum based lubricant to help hold the o-ring in place while replacing the cover.
- For the 17000K**, align key and keyway by rotating the impeller.

****Caution:** Replace impeller key and place the rubber cap over the key opening to prevent possible damage to the cover.

Thru-Key Design Impellers

(8000K, 10077K, 09000K, 09959K, 10615K, 15000K, 17000K*)

*17000A standard impeller in 17000K is threaded/thru-key design.

Removal

- Remove the cover.
- Twist and pull the impeller out of the pump.

Installation

- Apply a non-petroleum based lubricant to impeller (i.e. silicone or soapy water).
- For non-rock key version pumps, install the key into the shaft prior to installing the impeller.
- Install the impeller with a twisting motion onto the shaft.
- After the impeller is all the way on the shaft and into the housing, rotate the impeller to align the keyway of the shaft to the key slot on the shaft.
- Slide the impeller key into the keyway and if applicable place the rubber cap over the key opening.
- Then use a small amount of non-petroleum based lubricant to help hold the o-ring in place while replacing the cover.



Threaded Impellers



17000A Thru-Key Design



Thru-Key Impellers

*To maintain engine performance, insist upon genuine Sherwood impellers.
Keep it cool with the original!*

Impeller Specifications

10615K Width: 1-5/8" (41mm)
Diameter: 2-9/16" (65mm)

15000K Width: 2" (51mm)
Diameter: 2-9/16" (65mm)

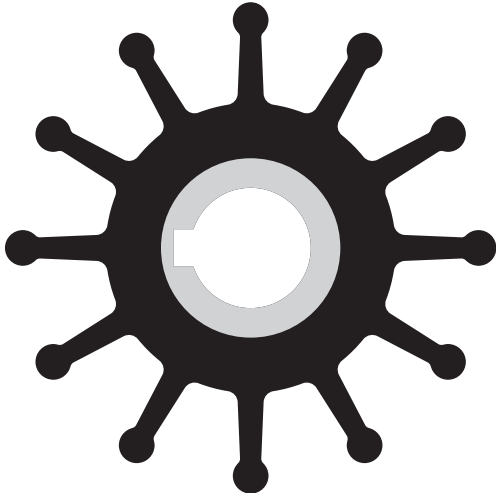

09959K Width: 1-1/4" (32mm)
Diameter: 2-7/16" (62.5mm)

09000K Width: 7/8" (22mm)
Diameter: 2-7/16" (62.5mm)

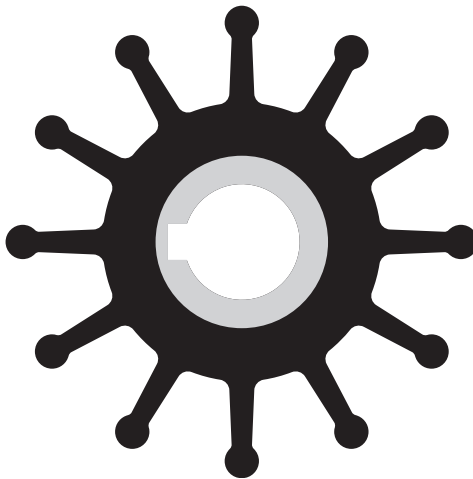

10077K Width: 25/32" (20mm)
Diameter: 2-1/4" (57mm)

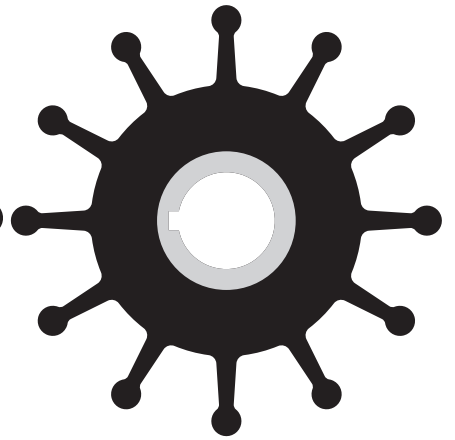

17000K Width: 2-7/8" (73mm)
Diameter: 3-5/16" (84mm)
Threaded/Thru-key
Insert

08000K Width: 3/4" (19mm)
Diameter: 1-9/16" (40mm)

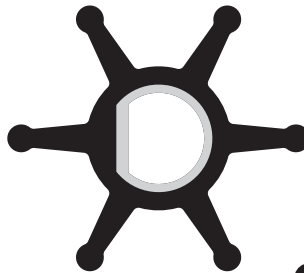

18000K Width: 4" (102mm)
Diameter: 3-3/4" (95mm)

Note: 18000S is an 18000 impeller with a stainless steel insert.

26000K Width: 3-1/8" (80mm)
Diameter: 3-3/4" (95mm)
Note: 26000 has a 45° Spline.

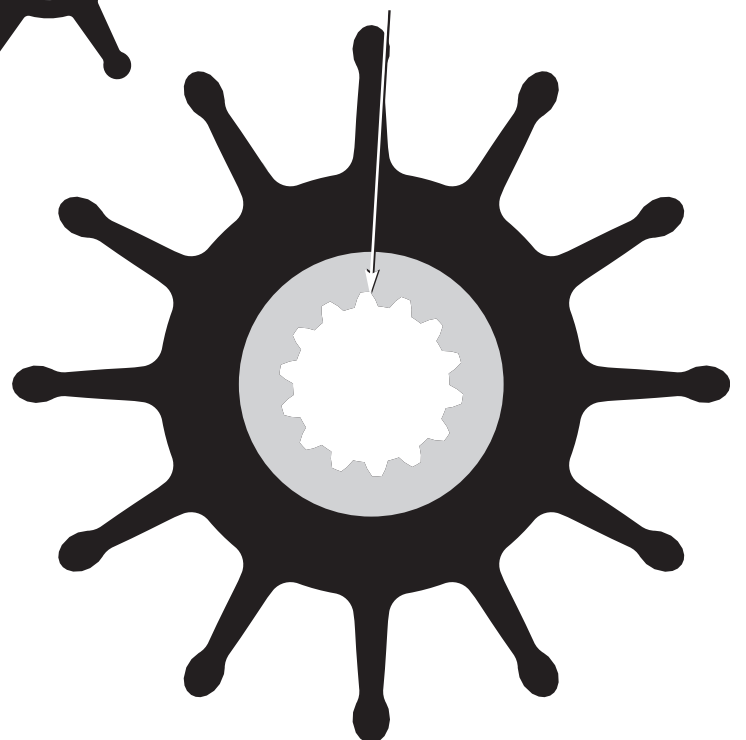
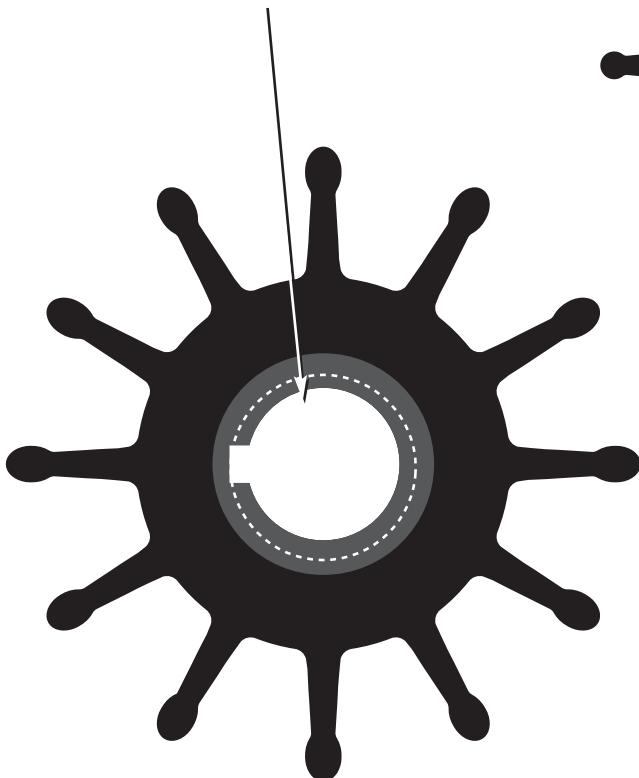

27000K Width: 2-7/8" (73mm)
 Diameter: 3-5/16" (84mm)
 Splined Impeller

22000K Width: 4-5/16" (110mm)
 Diameter: 4-1/2" (114mm)

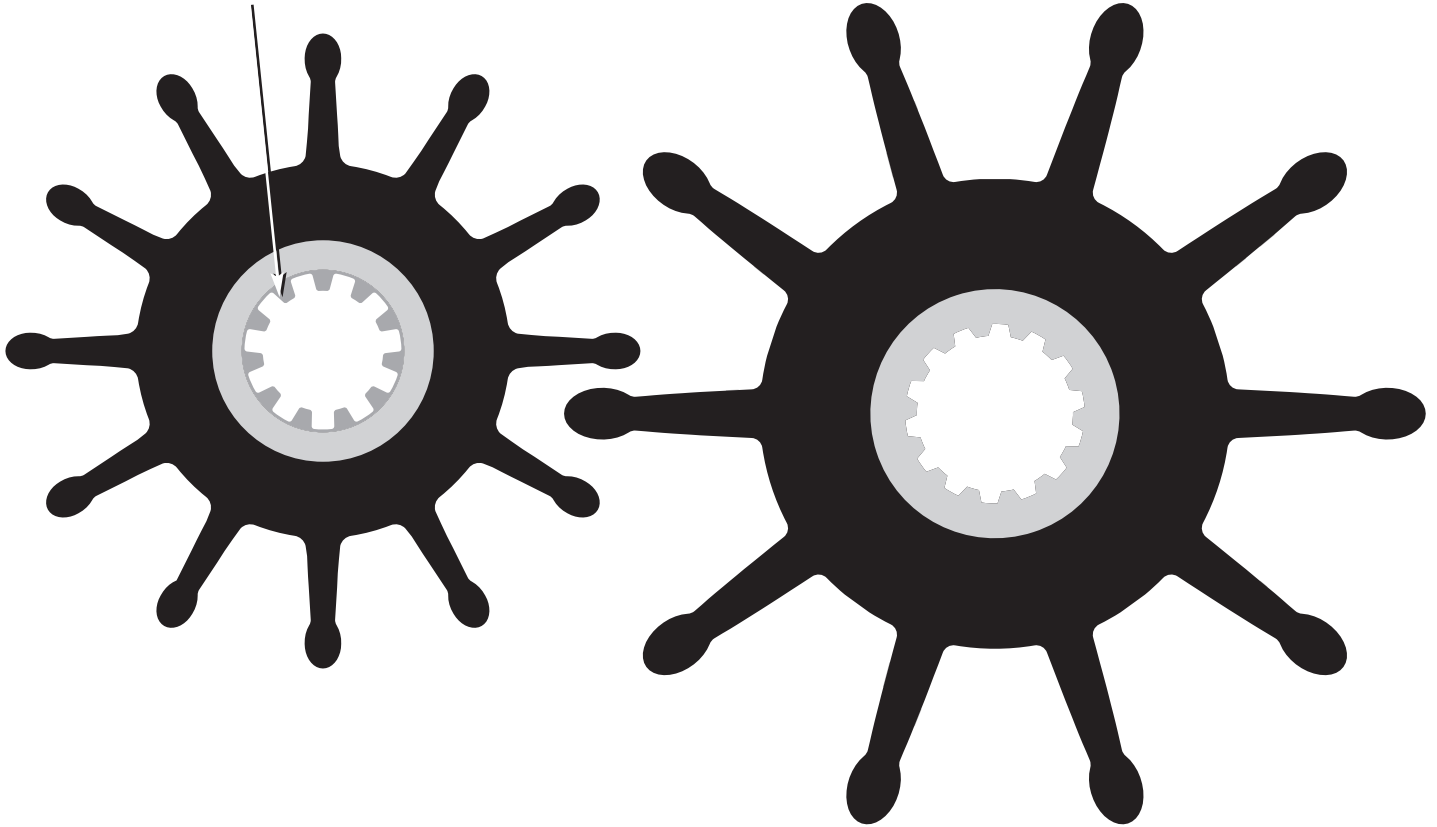

Additional Impellers

Part #	Diameter	Width	Shaft Diameter	Keyway	Number of Vanes
18200	2-9/16" (65mm)	2" (51mm)	5/8"	Spline	12
10187	2-19/32" (66mm)	1-31/32" (50mm)	5/8"	3/16"	9
10314	2-1/4" (57mm)	1-1/4" (32mm)	1/2"	1/8"	10

Vane Impellers

Vane Assembly Number	Vane Description	Number of Vanes Per Set	Vane Pumps
09731	1-1/4"L x 13/16"W x 1/8"H	7 (08888)	K9615G, K9635G, K9740G
09745	1-1/4"L x 13/16"W x 1/8"H	14 (08888)	K9529G, K9820G, L9841G, L9850G, L9870G, L9875G
09924	25/32"L x 11/16"W x 1/8"H	16 (09915)	L9910G, M10080G, N10160G

Impeller vanes were used for raw water pump applications prior to the design of the flexible rubber impeller. Vanes are packaged in sets and must be ordered by assembly number.

Seawater Strainer and Bracket



- Full-Flow Filtering with Ultra-Low Pressure Differential
- Easy In-Line Cleaning
- Durable Non-Corrosive Construction
- Quick Clear Bowl Examination
- Lightweight with Optional Mounting Bracket
- Stainless Steel Screens

Strainer Description

Strainer Number	Port Size (NPT)	Screen Mesh	Bracket No.
15935	1/2"	20 Mesh	N/A
18004	1/2"	50 Mesh	N/A
18001	3/4"	20 Mesh	14240
18005	1"	20 Mesh	14239
18016	1-1/4"	20 Mesh	14238
18029	1-1/2"	20 Mesh	21930

Strainer Components

Strainer Number	Screen No.	O-ring No.	Bowl No.
15935	11810	11805	14379
18004	11811	11805	14379
18001	11810	11805	14379
18005	11807	11803	14380
18016	14214	11803	14380
18029	16126	11803	14380

All Dimensions (In Inches):

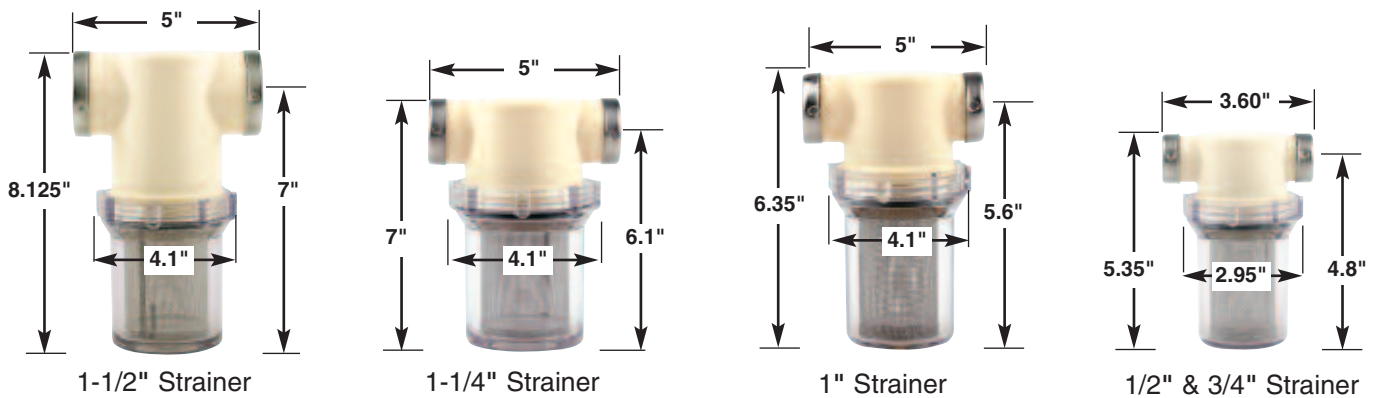

Pump Service Parts

Major Pump and Parts Service Section

The following parts list is made available for the identification of major components of raw water pumps currently active in marine engine applications. Although the pump may no longer be a unit in production, it may be a serviceable pump. This is intended to assist the distributors and their dealers with identification and ordering of parts.

Engine Manufacturer		Sherwood Number	Pump Avail	Replacement Pump	Ports		Impeller Kit	Minor Repair Kit	Major Repair Kit	Seal & Seat/Lip Seal
Engine Model	Engine Part Number				Inlet	Outlet				
Gov Life Boat	11658	B11	O	*	1/2" NPT	1/2" NPT	*		13369	11367
Gov Life Boat	11353	R10870G-01	S	R10870G	3/4" NPT	3/4" NPT	09959K	10997	12937	10927
Gov Life Boat	24143	H70	O	*	7/8"	7/8"	10077K	*	13366	11628C
Gov Life Boat	302648	G903	O	G908	1/2" NPT	1/2" NPT	09000K			12859/18806
Gov Life Boat	42175	G908-01	P	G908	1/2" NPT	1/2" NPT	09000K			12859/18806
Model 283	16.80-10003	N10360GX	S		1/2" NPT	1/2" NPT	(2) 10077K	10244	12301	10546
Model 307-327Q	16.80-28342	D10C	O	*	-	-	10635			10577
Model 307-327Q	16.80-28341	D15CC	O	*	-	-	10557			10577
M383X, M413E, M440X	E-7592-M	P10550G	O	D55	1 1/4"	1 1/4"	09959K & 10615K		*	10545
		P1730A	S		W/O Port Elbow	W/O Port Elbow	17000K			23799/24250

D10C	Centrifugal recirculating pump clockwise rotation from pulley end
D15CC	Centrifugal recirculating pump counterclockwise rotation from pulley end

O	Obsolete pump, no longer in production
P	Proprietary pump, must purchase through engine manufacturer or their distributor
S	Sherwood pump, purchase direct from Sherwood distributor

R10870G	Pump shown in this column is a direct replacement
*	Asterisk indicates no direct replacement available

NPT indicates threaded port (national pipe thread)	1/2" NPT	1/2" NPT
Dimension indicates outside diameter of port	1 1/4"	1 1/4"
Signifies that the pump is sold without any port elbows	W/O Port Elbow	W/O Port Elbow

For gear pumps, first item drive gear, second item is the idler	05237/05725
Rubber Impeller (2) per pump	(2) 10077K
Pump uses both a 09959 and 10615 impeller	09959K & 10615K

Complete Seal and Seat Assembly	10545
Mechanical Seal followed by the Lip Seal	23799/24250

GENERAL PARTS INFORMATION

*Asterisk indicates parts are obsolete.

Blank space indicates part not used in pump design.

ENGINE MANUFACTURER		SHERWOOD NUMBER	PUMP AVAIL	PREPLACEMENT PUMP	PORTS		IMPELLER KIT	MINOR REPAIR KIT	MAJOR REPAIR KIT	SEAL & SEAT/ LIP SEAL	BEARING ASSEMBLY
ENGINE MODEL	ENGINE PART NO.				INLET	OUTLET					
CHRIS CRAFT											
Model A		G8456	O	*						*	
Model A		A16	O	*	1"	1"	09959K			10927	4257
Model B		D7704	O	*	3/8"	3/8"				*	*
Model B		D7730	O	*	3/8"	3/8"				*	*
Model B		G8450	O	*	3/8"	3/8"				*	4306
Model B		K9750G	O	*	3/8"	3/8"				10546	4306
Model B		M10261G	O	*	3/8" NPT	3/8" NPT	10077K			10546	4306
Model K		D7669	O	*	1/2"	1/2"				*	*
Model K		D7729	O	*	1/2"	1/2"				*	*
Model K		G8451	O	*	1/2"	1/2"				10522	4306
Model K		K9710G	O	*	1/2"	1/2"				10546	4306
Model K	16.80-10007	M10262G	O	*	1/2" NPT	1/2" NPT	10314			10546	4306
Model M		D7710	O	*	3/4"	3/4"				*	*
Model M		D7731	O	*	3/4"	3/4"				*	*
Model M		G8452	O	*	3/4"	3/4"				*	4306
Model M		K9635G	O	*	3/4"	3/4"				10546	4306
Model M	16.80-10008	M10263G	O	*	3/4" NPT	3/4" NPT	09959K	09959K	12246	10545	4306
Model W		G8453	O	*	1"	1"				*	*
Model W		K9740	O	*	1"	1"				10545	4257
Model W	16.80-10009	M10264G	O	*	1" NPT	1" NPT	09959K	09959K		10545	4257
Model 283		L9980G	O	N10360GX	1/2"	1/2"				10546	4306
Model 283		L9910G	O	N10360GX	1/2"	1/2"	09924			10546	4306
Model 283		N10160G	O	N10360GX	1/2"	1/2"	09924			10546	*
Model 283		M10095G	O	N10360GX	1/2"	1/2"	(2) 10077K	10244		10546	4306
Model 283	16.80-10003	N10360GX	S		1/2" NPT	1/2" NPT	(2) 10077K	10244	12301	10546	4306
Model 283M		L9980G	O	N10360GX	1/2"	1/2"				10546	4306
Model 283F		Q10780G	O	S11095G	1" NPT	1" NPT				10545	19988
Model 283F	16.80-27555	Q10825CC	O	*	-	-	*		12249	10577	14055
Model 283F	16.80-27554	Q10830C	O	*	-	-	10635		12249	10577	14055
Model 307-327Q	16.80-18340	D05	O		1"	1"	10615K	11430		10927	(2) 4257
Model 307-327Q	16.80-28342	D10C	O	*	-	-	10635			10577	14055
Model 307-327Q	16.80-28341	D15CC	O	*	-	-	*			10577	14055
Model 327F		Q10780G	O	S11095G	1" NPT	1" NPT				10545	19988
Model 327F		S11095G	S		1"	1"	10615K			10545	19988
Model 327F		Q10825CC	O	*	-	-	*		12249	10577	14055
Model 327F		Q10830C	O	*	-	-	10635		12249	10577	14055
Model 427	16.80-10010	S11095G	S		1"	1"	10615K	11102	12308	10545	19988
Model 427	16.80-07808	S11110C	O	*	-	-	10635			10577	14055
Model 427	16.80-11007	S11115CC	O	*	-	-	*			10577	14055
Model 430		N10450	O	N10360GX	-	-				10545	4257
Model 430		M10080G	O	N10360GX	-	-	09924			10546	4306
Model 430		N10200G	O	N10360GX	-	-	(2)10077			10546	4306
Model 430		N10370G	O	N10360GX	-	-	(2)10077			10546	4306
Model 430	16.80-10003	N10360GX	S		1/2" NPT	1/2" NPT	(2)10077	10244	12301	10546	4306
Model 431		P10670	O	N10360GX	-	-				10545	4257
Model 431		N10490CC	O	*	-	-	*			10577	14055
Model 431		N10580C	O	*	-	-	10635			10577	14055
Model 350	16.80-18344	G15	S		1"	1"	09959K	23979	12665	12859	(2) 23448
Model 350	16.80-18346	G30-2	O	G30-2B	1"	1"	09959K	23979	12665	12859	(2) 23448
Model 350	16.80-18346	G30-2B	S		1"	1"	09959K	23979	12665	12859	(2) 23448
Model 454	16.80-18347	G45-1	S		1 1/4"	1 1/4"	10615K	23976	23977	12859	(2) 23448

Pumps by Engine Manufacturer

SHAFT	CAM	GASKET / O-RING	BUSHING	BODY	CAM SCREW	COVER	HOUSING	WEAR PLATE	KEY	PIN	SLINGER	RETAINING RING	PULLEY / GEAR / HUB / ADAPTER
*				*		*	*		17658	*	7070		*
*	10072	10103	6333	*			*		4432	1311	1410-0056	(2) 4258/4259 (1)	*
*		(4) 5248		*	*	*	*		17658	*	7070		
*		(4) 5248	*	*	*	*	*		17658	*	7070		
*		(4) 5248	*	*	*	*	*	*	17658	*	7070		*
*	*	9484	2075	*		*		*		*	7070		
*	10285	10286	2075	*	12686	10279			10093	*	7070	4304	
*		(4) 5248	*	*	*	*	*	*	17658	*	7070		
*		(4) 5248	*	*	*	*	*	*	17658	*	7070		
*		(4) 5248	*	*	*	*	*	*	17658	*	7070		
*	*	9484	2075	*		*		*		*	7070		*
*	*	10286	2075	*	10195	10279		10079	17658	*	7070	4304	
*		(4) 5248	*	*	*	*	*	*	17658	*	7070		
*		(4) 5248	*	*	*	*	*	*	17658	*	7070		
*		(4) 5248	*	*	*	*	*	*	17658	*	7070		
*	*	9484	2075	*		*		*		*	7070		*
*	10072	10103	6333	*	9919	10094			4432	*	14990	4258	
*		*	*	*	*	*		*	17658	*	7070		
*	*	9484	6333	*		*		*		528	*		*
*	10072	10103	6333	*	9919	10094		12317	4432	528	14990	4258	
*		*	*	*	*	*	*	*	17658	528	7070	4304	
*	*	9917/9918	2075	9909	9919	9907	*	*		528			*
*	*	9917/9918	2075	9909	9919	9907	*	*		528			*
10078	10134	9917/9918	2075	9909	9919	9907	*	10079	10093	528		4304	
10078	10134	9917/9918	2075	9909	9919	9907	10416C	10079	10093	528		4304	
*		*	2075/*	*	12686	*	*	*	17658	528	7070	4304	
		*	6333/*	*	*		*	*	4432	9420		4258	10769
		10575				*	*				1410-0056	10574	
		10575				*	*				1410-0056	10574	
11429	10944	10931	6333	11428	10515		*		4432	1311		(2) 4258/4259 (1)	
		15945				*	*				1410-0056	10574	
		15945				*	11419				1410-0056	10574	
*		*	6333/*	*	*		*	*	4432	9420		(2) 4258	10769
14212	10944	10971	6333		10515	10182	10957		4432	9420		(2) 4258/8781 (1)	10769
		10575					*				1410-0056	10574	
		10575					*				1410-0056	10574	
14212	10944	10971	6333		10515	10182	10957		4432	9420		(2) 4258/8781 (1)	10769
							*				1410-0056	10574	
							*				1410-0056	10574	
*		*	6333/*	*	*	*	*	*	17658	528	*	4258	
*	10134	9917	2075	9909	9919	*	*	*		528			*
10078	10134	9917	2075	9909	9919	*	*	*	10093	528		4304	
10078	10134	9917	2075	9909	9919	*	*	*	10093	528		4304	
10078	10134	9917/9918	2075	9909	9919	9907	10416	10079	10093	528		4304	
*		*	6333/*	*	*	*	*	*	17658	528		4258	
		10575				*	*				1410-0056	*	*
		10575				*	*				1410-0056	*	*
12233	15883	12231/12855		12324	10515		12303	12856	4432/12622			"12305/(2), 4258/4259 (2)"	12323
12612	15883	12231/12855		12328	10515		12303	12856	4432	12791		(3) 4258/4259 (2)	12615
12612	15883	12231/12855		19784	10515		12303	12856	4432	12791		(3) 4258/4259 (2)	12615
12612	10944	12231/12855		12328	10515		12228	12856	4432	12791		(3) 4258/4259 (2)	12615

SERVICE

ENGINE MANUFACTURER		SHERWOOD NUMBER	PUMP AVAIL	PREPLACEMENT PUMP	PORTS		IMPELLER KIT	MINOR REPAIR KIT	MAJOR REPAIR KIT	SEAL & SEAT/ LIP SEAL	BEARING ASSEMBLY
ENGINE MODEL	ENGINE PART NO.				INLET	OUTLET					
CHRYSLER MARINE											
318 and 360	4142878	G7	O	G7B	1 1/4"	1 1/4"	10615K	23976	23977	12859	(2) 23448
318 and 360	4142878	G7B	S		1 1/4"	1 1/4"	10615K	23976	23977	12859	(2) 23448
M80 (CW)	E5913-M	P10560G	O	*	-	-	(2)09959K			10545	*
M80 (CCW)	E5839-M	P10710G	O	*	-	-	(2)09959K			10545	*
Slant 6	E-7783-M	P10610G	O	*	-	-	09959K	09959K	12252	10545	4257
Slant 6	2659553	A03	O	*	-	-	09959K		12792	10545	4257
M225X	E-8542-M	Q10855G	O	D60	1"	1"	(2) 09959K	09959K		10545	19988
M225X	2847632	D75	O	D60	1"	1"	(2) 09959K	10656		10927	4257
M273X, LM318X	E-9327-M	R10935G	O	D60	1"	1"	(2) 09959K	09959K	12814	10545	19988
M273X, LM318X	2847630	D60	S		1"	1"	(2) 09959K	10656	12300	10927	4257
M273X, LM318X	E-7584-M	N10390G	O	D60	1"	1"	(2) 09959K	09959K	12814	10545	19988
M273X, LM318X	2847631	D65	O	D60	1"	1"	(2) 09959K	10656	12300	10927	4257
M383X, M413E, M440X	E-7592-M	P10550G	O	D55	1 1/4"	1 1/4"	09959K & 10615K			10545	19988
M383X, M413E, M440X	2847629	D55	S		1 1/4"	1"	09959K & 10615K			10927	4257
LM318-X, LM340-X	2846428	C-03	O	G7B	-	-	10615K	10999	11068	10927	4257
LM318-X, LM340-X	3675763	G5	O	G7B	1 1/4"	1 1/4"	10615K	23976	23977	12859	(2) 23448
LM318-X, LM340-X	3745511	G5-1	O	G7B	1 1/4"	1 1/4"	10615K	23976	23977	12859	(2) 23448
LM318-X, LM340-X	3619030	F10	O	G50	1 1/4"	1 1/4"	10615K	10999	11068	10927	4257
LM318-X, LM340-X	3619212	G50	S		1 1/4"	1 1/4"	10615K	23976	23977	12859	(2) 23448
COMMANDER											
302 and 351	CM1-10-610	J70	S		1"	1"	09959K	23979	12665	12859	(2) 23448
302 and 351	C2-10-610	L80	S		1 1/4"	1 1/4"	10615K	23976	23977	12859	(2) 23448
CRUSADER (DEARBORN)											
Model 220,270,300,350	97179	E35	S		1" NPT	1" NPT	10615K	10999	11068	10927	4257
Chevy RH Rotation		L9820G	O	*	-	-	09745			10545	4257
Chevy RH Rotation		L9870G	O	*	-	-	09745			10545	4257
Chevy RH Rotation		M10270G	O	*	1" NPT	1 1/4"	(2)09959K			10545	4257
Chevy LH Rotation		L9841G	O	*	-	-	09745			10545	4257
Chevy LH Rotation		L9875G	O	*	-	-	09745			10545	4257
Chevy LH Rotation		M10280G	O	*	1" NPT	1 1/4"	(2)09959K			10545	4257
Chevy LH Rotation		Q10755G	O	*	-	-	09959K			10545	4257
Chevy LH Rotation	1000269	Q10775G	O	*	-	-	10187		12819	10758	4257
Chevy LH Rotation	1001984	S11085G	O	*	1 1/2"	1"	10187		12819	10758	4257
Chevy RH Rotation		Q10765G	O	*	-	-	09959K			10545	4257
Chevy RH Rotation	1000270	Q10785G	O	*	-	-	10187		12819	10758	4257
Chevy RH Rotation	1001985	S11090G	O	*	1 1/2"	1"	10187		12819	10758	4257
Interceptor		M10210G	O	P10700G	-	-	09959K	09959K	12252	10545	4257
Interceptor		N10410G	O	P10700G	-	-	09959K	09959K	12252	10545	4257
Interceptor		P10700G	S		3/4" NPT	3/4" NPT	09959K	09959K	12252	10545	4257
Interceptor		F15	O	R50G	3/4" NPT	3/4" NPT	09959K			10927	4257
Model 220,270,300,350		S11040G	O	E35	1" NPT	1" NPT	10615K	10999	11068	10927	4257
Model 220,270,300,350		B04	O	E35	1" NPT	1" NPT	10615K	10999	11068	10927	4257
Model 220,270,300,350	40070	P102	O	P105	1 1/4"	1 1/4"	10615K	10615K	19354	18652	8490
Model 220,270,300,350		R101	O		1" NPT	1" NPT	10615K		18653	10927	4257
Model 220,270,300,350	40050	P101	P	P1014	1 1/4"	1 1/4"	10615K	19301	19300	12859	(2) 23448
Chevy V6	97512	H10	O	*	1"	1"	09959K	23979	12665	12859	(2) 23448
ESCORT (SKILTEC)											
302 and 351		F75	O	*	1" NPT	1" NPT	10615K			10927	4257
302 and 351	D5MZ8502	G85	S		1 1/4"	1 1/4"	10615K	23976	23977	12859	(2) 23448

SHAFT	CAM	GASKET / O-RING	BUSHING	BODY	CAM SCREW	COVER	HOUSING	WEAR PLATE	KEY	PIN	SLINGER	RETAINING RING	PULLEY / GEAR / HUB / ADAPTER
13363	10929	12231/12855		12227	10515		12952	12856	4432			(3) 4258/4259 (2)	15055
13363	10929	12231/12855		19789	10515		12952	12856	4432			(3) 4258/4259 (2)	15055
*	(2) 10072	(2) 10103	6333	*	(2) 9919	10094	*	*	4432				
*	(2) 10072	(2) 10103	6333	*	(2) 9919	10094	*	*	4432				*
	10072	10103	6333	*	9919	10094	*		4432/*	1311		4258/4259	
*	10072	*	6333	*	9919				4432	1311	*	4258/4259	*
10501C	(2) 15883	(2) 10609	6333		(2) 10515	*	*	10625	(2) 4432	(2) 413	*	4258/8781	*
11459	(2) 15883	(2) 10609	6333	11454	(2) 10515	10611		10625	(2) 4432/11515	(2) 413		(3) 4258/4259 (1)	12326
10501C	(2) 15883	(2) 10609	6333	*	(2) 10515	10913	*	10625	(2) 4432	(2) 413	*	4258	*
11459	(2) 15883	(2) 10609	6333	11454	(2) 10515	10913		10625	(2) 4432/11515	(2) 413		(3) 4258/4259 (1)	12326
10501C	(2) 15883	(2) 10609	6333	*	(2) 10515	*	*	10625	(2) 4432/*	(2) 413	*	4258/8781	*
11459	(2) 15883	(2) 10609	6333	11454	(2) 10515	10611		10625	(2) 4432/11515	(2) 413		(3) 4258/4259 (1)	12326
*	15883/10944	10609/10612	6333	*	(2) 10515	*		10625	(2) 4432	(2) 413	*	4258/8781	*
11460	15883/10944	10609/10612	6333	11455	(2) 10515	10611		10625	(2) 4432/11515	(2) 413		(3) 4258/4259 (1)	12326
*	10944	10612	6333	*	10515	*			4432	1311		(2) 4258/4259	*
12233	10944	12231/12855		12227	10515		12228	12856	4432	11541		(2) 4258/4259 (2)	12326
12233	10929	12231/12855		12227	10515		12952	12856	4432	11541		(2) 4258/4259 (2)	*
*	10944	10612	6333	*	10515	*			4432	1311		(3) 4258/4259	*
12233	10944	12231/12855		12227	10515		12228	12856	4432	11541		“(3) 4258/4259, (2) 12305”	12323
13274	15883	12231/12855		12328	10515		12303	12856	4432/12622			(3) 4258/4259 (2)	13429
13274	10944	12231/12855		12328	10515		12228	12856	4432/12622			(3) 4258/4259 (2)	13429
11744	10944	10931	6333	11245	10515	10182			4432	(2) 1311		(2) 4258/4259 (1)	97176
*	*	9484	6333	*	*	*	*	*		413		4258/4259	*
*	*	9484	6333	*	*	*	*	*		413		4258/4259	*
*	*	(2) 10103	6333	*	9919	10094	*	*	(2) 4432	413		(2) 4258/4259	*
*	*	9484	6333	*	*	*	*	*		413		4258/5328	*
*	*	9484	6333	*	*	*	*	*		413		4258/5328	*
*	*	(2) 10103	6333	*	9919	10094	*	*	(2) 4432	413		(2) 4258/4259	*
*	15883	*	6333	*	10515	*	*		4432	1311		(2) 4258/4259	*
10748	*	10752	6333	*	10515	*	*		4432	1311		(2) 4258/4259	
10748	*	10752	6333	*	10515	*	*		4432	1311		(2) 4258/4259	
*	15883	*	6333	*	10515	*	*		4432	1311		(2) 4258/4259	
10748	*	10752	6333	*	10822	*	*		4432	1311		(2) 4258/4259	
10748	*	10752	6333	*	10822	*	*		4432	1311		(2) 4258/4259	
10256	10072	10103	6333	*	9919	10094		10254	4432	1311		4258/4259	
10256	10072	10103	6333	*	9919	10094		10254	4432	1311		4258/4259	
10256	10072	10103	6333	10662	9919	10094		10254	4432	1311		(2) 4258/4259	
10852	10072	10103	6333	10176	9919	10094	15104		(2) 4432	1311		(3) 4258/4259	
*	10944	10931	6333	*	10515	10182			4432	1311		4258/4259	97176
11744	10944	10931	6333	11245	10515	10182			4432	1311		4258/4259	97176
19308	10944	12231		21378	10515	21120			4432			5126/6837	19275
*	10944	12231	6333		10515	18468	18467		12841			(3) 4258/4259 (1)	
19293	10944	19251		19294	10515	23946		19295	4432			(2) 4258/4259 (1)	97176
12596	15883	12231/12855		12328	10515		12303	12856	4432			(2) 4258/4259 (2)	97176
12316	10944	10971	6333		10515	10182	*	*	4432	1311		(2) 4258/4259	10769
12596	10944	12231/12855		12328	10515		12228	12856	4432	9420		(3) 4258/4259 (2)	10769

ENGINE MANUFACTURER		SHERWOOD NUMBER	PUMP AVAIL	PREPLACEMENT PUMP	PORTS		IMPELLER KIT	MINOR REPAIR KIT	MAJOR REPAIR KIT	SEAL & SEAT/ LIP SEAL	BEARING ASSEMBLY
ENGINE MODEL	ENGINE PART NO.				INLET	OUTLET					
GLASTRON BOAT CO.											
121, 182, and 302 CI		G95-1	O		1"	1"	09959K	23979	12665	12859	(2) 23448
GRAY MARINE											
4 Cyl	G78478	N10510G	O	*	-	-	09959K			10545	4257
4 Cyl	G78972	P10650G	O	*	-	-	09959K		12242	10545	4257
4 Cyl	G77560	L9930G	O	*	3/4" NPT	3/4" NPT	09959K			10545	4257
6 Cyl	G77160	K9615G	O	*	-	-	09731			10545	4257
6 Cyl	G77475	M10065G	O	*	-	-	09959K			10545	4257
6 Cyl	G77560	L9930G	O	*	-	-	09959K			10545	4257
Fireball V8 (CW Rotation)	G75842	K9529G	O	*	-	-	09745			10545	4257
Fireball V8 (CW Rotation)	G77532	L9850G	O	*	-	-	09745			10545	4257
Fireball V8 (CW Rotation)	G80785	R10925G	O	*	-	-	09959K			10545	4257
Fireball V8 (CW Rotation)	G77586	M10180G	O	*	-	-	(2)09959K			10545	4257
Fireball V8 (CCW Rotation)	G80784	R10920G	O	*	-	-	09959K			10545	4257
Fireball V8 (CCW Rotation)	G77585	L9920G	O	*	-	-	(2)09959K			10545	4257
Compact V8 215,225 CCW	G80301	N10460	O	*	-	-	09959K			10513/10514	4257
Compact V8 215,225 CW	G80300	N10470	O	*	3/4" NPT	3/4"	09959K			10513/10514	4257
Gov Engine	G76647	Q10770G	O	*	-	-	09959K	09959K		10545	4257
Gov Engine	G80971	R10955G	O	*	-	-	09959K	09959K		10545	4257
Gov Engine	G85106	R10970G	O	*	-	-	10615K	10999		10927	4257
Gov Engine	G80561	Q10840	O	*	1/2" NPT	1/2" NPT	10077K			10859/11628C	(2) 4306
Gov Engine	G80953	R10945CC	O	*	1 1/2"	1 1/4"	*	12249		10577	
Gov Engine	G80954	R10950C	O	*	1 1/2"	1 1/4"	10635	12249		10577	
INTERCEPTOR											
		M10210G	O	P10700G	-	-	09959K	09959K	12252	10545	4257
		N10410G	O	P10700G	-	-	09959K	09959K	12252	10545	4257
		P10700G	S		3/4" NPT	3/4" NPT	09959K	09959K	12252	10545	4257
		F15	O	R50G	3/4" NPT	3/4" NPT	09959K			10927	4257
ISUZU											
4, 6 Cyl Diesel	X-26230-1023	K90	S		1 1/4"	1 1/4"	10615K	23976	23977	12859	(2) 23448
KOHLER											
4, 6 Cyl Diesel		G906P	O	**	3/8" NPT	3/8" NPT	09000K			18570	(2) 23448
Ford		G907P-01	S	G907P	3/8" NPT	3/8" NPT	09000K			22546	(2) 23448
4-6.5 KW Gas		G907-01	S	G907P	3/8" NPT	3/8" NPT	09000K			22546	(2) 23448
LENCO											
		L90	O	G7	1 1/4"	1 1/4"	10615K	23976	23977	12859	(2) 23448
MARINE CORP. OF AMER. (SEE STAR POWR)											
MARINE POWER											
		G157	S		1 1/2"	1 1/2"	15000K	23980	23981	12859	(2) 23448
		P105	S		1 1/4"	1 1/4"	10615K	10615K	19354	18652	8490
NORTH AMERICAN ENGINE											
6.2L Diesel		G56	S		1 1/4"	1 1/4"	10615K	23976	23977	12859	(2) 23448
ONAN											
12MDJC-15 MDJF		RPGC	O	*	3/4" NPT	3/4" NPT	09959K	09959K	12246	10545	4306
30MDEH-50MDEG		RPGC	O	*	3/4" NPT	3/4" NPT	09959K	09959K	12246	10545	4306
4Cyl Diesel		K75	O	K75B	1"	1"	09959K	23979	12665	12859	(2) 23448
4Cyl Diesel		K75B	S		1"	1"	09959K	23979	12665	12859	(2) 23448
5Cyl Diesel		L10	O	L10B	1 1/4"	1 1/4"	10615K	23976	23977	12859	(2) 23448
5Cyl Diesel		L10B	S		1 1/4"	1 1/4"	10615K	23976	23977	12859	(2) 23448
5Cyl Diesel		G905	O		1"	1"	09000K			12859/18570	(2) 23448
5Cyl Diesel		G1004	O	G1006	1"	1"	10615K	10615K	22014	21208/21209	(2) 23448
5Cyl Diesel		G1005	O	G1006	1"	1"	10615K	10615K	22014	21208/21209	(2) 23448

** Kohler Replacement for "G-906P with pulley" is G-907P; "without pulley", use G-906.

SHAFT	CAM	GASKET / O-RING	BUSHING	BODY	CAM SCREW	COVER	HOUSING	WEAR PLATE	KEY	PIN	SLINGER	RETAINING RING	PULLEY / GEAR / HUB / ADAPTER
*	15883	12231/12855		12328	10515		12303	12856	4432	11543		(3) 4258/4259 (2)	*
*	10072	10103	6333	*	9919	10094	*		4432	1311		4258/4259	
*	10072	10103	6333	*	9919	10094	*		4432	1311		4258/4259	*
*	10072	10103	6333	*	9919	10094			4432	1311		4258/4259	
*	*	9484	6333	*	*	*		*		1311		4258/4259	*
*	10072	9484	6333	*	9919	*		*	4432	1311		4258/4259	
*	10072	10103	6333	*	9919	10094			4432	1311		4258/4259	
*	*	9484	6333	*	*	*	*	*		*		4258/4259	
*	*	9484	6333	*	*	*	*	*		413		4258/4259	*
*	10072	(2) 10103	6333	*	9919	10094	*	*	4432	413		4258/4259	*
*	(2) 10072	(2) 10103	6333	*	9919	10094	*	*	4432	413		4258/4259	*
*	10072	(2) 10103	6333	*	9919	10094	*	*	4432	413		4258/4259	*
*	(2) 10072	(2) 10103	6333	*	9919	10094	*	*	4432	413		4258/4259	*
*	10072	10512		*	10515	*	*		4432	1311	*	5328/4259	*
*	10072	10512		*	10515	*	*		4432	1311	*	5328/4259	*
*	10072	10103	6333	*	10515	10094			4432	1311		(3) 4258/4259	
*	10072	10103	6333	*	10515	10094			4432	1311		(3) 4258/4259	*
*	10929	10931	6333	*	10515	10182			4432	1311	7070	4258/4259	*
10858	10285	10286		*	10195	10593			10093	*	*	4303/4304	*
14055		10575				*	*				*	10574	*
14055		10575				*	*				*	10574	*
10256	10072	10103	6333	*	9919	10094		10254	4432	1311		4258/4259	
10256	10072	10103	6333	*	9919	10094		10254	4432	1311		4258/4259	
10256	10072	10103	6333	10662	9919	10094		10254	4432	1311		(2) 4258/4259	
10852	10072	10103	6333	10176	9919	10094	15104		(2) 4432	1311		(3) 4258/4259	
12596	10944	12231/12855		12227	10515		12228	12856	4432			(3) 4258/4259 (2)	*
18569	18663	19964			10195	24125	19963		13777			4258/4259	19967
21861	18663	19964			10195	24125	21862		13777			(2) 4258/4259	21859
21861	18663	19964			10195	24125	21862		13777			(2) 4258/4259 (1)	
12233	10944	12231/12855		12227	10515		12228	12856	4432/12622	11541		12305 (2) 4258/4259	12326/12393
21231	18314	12231/12855		12227	10515		17684	12856	4432			(3) 4258/4259 (2)	
19308	10944	12231		21378	10515	21120			4432			5126/6837	19275
12596	10944	12855/12231		12328	10515		12907	12856	4432	9420		(2) 4258/4259 (3)	10769
*	10072	10103	6333	*	9919	10094			4432	1311	14990	4258/5484	
*	10072	10103	6333	*	9919	10094			4432	1311	14990	4258/5484	
13363	15883	12231/12855		*	10515		13793	12856	4432			(3) 4258/4259 (2)	13795
13363	15883	12231/12855		19948	10515		13793	12856	4432			(3) 4258/4259 (2)	13795
13363	10929	12231/12855		*	10515		13899	12856	4432			(3) 4258/4259 (2)	13795
13363	10929	12231/12855		19948	10515		13899	12856	4432			(3) 4258/4259 (2)	13795
*		(2)19964/19257		*		*	*	*				(3) 4258/4259	
21207	10929	12231		*	10515	21173	21150	21163	4432			4258/4259 (2)	
21207	10929	12231		*	10515	21173	21150	21163	4432			4258/4259 (2)	

ENGINE MANUFACTURER		SHERWOOD NUMBER	PUMP AVAIL	PREPLACEMENT PUMP	PORTS		IMPELLER KIT	MINOR REPAIR KIT	MAJOR REPAIR KIT	SEAL & SEAT/ LIP SEAL	BEARING ASSEMBLY
ENGINE MODEL	ENGINE PART NO.				INLET	OUTLET					
OSCO MOTORS		P105	S		1 1/4"	1 1/4"	10615K	10615K	19354	18652	8490
OWENS FLAGSHIP MARINE											
Model V8	6587	L9887	O	*	-	-				7269/10546	*
	M10230	O	*	-	-	-			7269/10546	*	*
	Q10750	O	*	-	-	-			10545	*	*
OMC											
In Board	981939	G45-2	O	G46	1 1/4"	1 1/4"	10615K	23976	23977	12859	(2) 23448
V8 Chevy	981937	H-85	O		1 1/4"	1 1/4"	10615K	23976	23977	12859	(2) 23448
V8 Chevy	985096	G46	S		1 1/4"	1 1/4"	10615K	23976	23977	12859	(2) 23448
6-8 Cyl	3852398	G9901	S		1 1/4"	1"	09959K	23979	12665	12859	(2) 23448
4Cyl	3852399	G9902	O	G9903	1 1/4"	1"	09959K	23979	12665	12859	(2) 23448
4Cyl	3855079	G9903	S		1 1/4"	1"	09959K	23979	12665	12859	(2) 23448
PALMER											
I.H. 60		E20	O	*	1/2" NPT	1/2" NPT	10077K			10859/11628	4306
PATHFINDER VOLKSWAGON ENG.											
4 Cyl		J90	O	*	1"	1"	09959K			12859	*
PERKINS ENGINE U.S.											
40-107 Diesel		B06	O	G65	3/4" NPT	3/4" NPT	09959K	09959K	11421	11237/10514	*
40-108 Diesel	NA003335	G65	S		3/4" NPT	3/4" NPT	09959K	09959K	12221	10514C	(2) 23448
4-154 Diesel	NA005576	H5	S		1"	1"	09959K		12980	10514/06602	(2) 4257
6-354 Diesel	NA001175	RPBC	S		1" NPT	1" NPT	10615K	10999	11068	10927	4257
PLEASURECRAFT MARINE											
Chevy 454		G55-2	S		1 1/4"	1 1/4"	10615K	23976	23977	12859	(2) 23448
302 and 351		G20	O	G21	1"	1"	09959K	23979	12665	12859	(2) 23448
302 and 351		G21-01	P	G21	1"	1"	09959K	23979	12665	12859	(2) 23448
Mitsubishi 4 Cyl		G22-01	P	G22	-	-	09959K	23979	12665	12859	(2) 23448
7.3L Diesel		G26-01	P	G26	1 1/4"	1 1/4"	10615K	23976	23977	12859	(2) 23448
STARPOWER											
Inboard		G151	S		1 1/2"	1 1/2"	15000K	23980	23981	12859	(2) 23448
Stern Drive	800790MI	G155	S		1 1/2"	1 1/2"	15000K	23980	23981	12859	(2) 23448
UNIVERSAL MEDALIST											
Atomic Four		L9960	O	T11165	-	-	09979			*	
Atomic Four		T11165	O	*	3/8"	3/8"	09979	12949		10514C	
Utilty Four		T11166	O	*	-	-	09979	12949		10514C	
Model OK-OL		L9790G	O	*	-	-	*			10546	4306
Model OK-OL		Q10805G	O	*	3/8"	3/8"	10077K			10546	4306
Sabre V6		R10930G	O	*	3/4"	3/4"	09959K	10997		10545	4257
Light Plants		E05	O	R30G	1/2"	1/2"	10077K	10996	24025	11367	4306
Light Plants		R10870G	S	R50G	3/4" NPT	3/4" NPT	09959K	10997	12937	10927	4257
Light Plants	299805	H80A	O	G908	3/8"	3/8"	12336	11876		(2) 10514C	
Light Plants	300986	M5	O	G908	3/8"	3/8"	12336	11876		(2) 10514C	
Light Plants	302648	G903	O	G908	1/2"	1/2"	09000K			12859/18806	(2) 23448
U.S. MARINE											
351 Ford		P151	O		1 1/4"	1 1/4"	15000K			18652	(2) 18662

SHAFT	CAM	GASKET / O-RING	BUSHING	BODY	CAM SCREW	COVER	HOUSING	WEAR PLATE	KEY	PIN	SLINGER	RETAINING RING	PULLEY / GEAR / HUB / ADAPTER
19308	10944	12231		21378	10515	21120			4432			5126/6837	19275
*		(2) 5248	2075/*	*	*	*	*	*	17658	1311		4304	*
	*	2075/*	*	*	*	*	*	17658	1311		4304	*	
	*	6333 (2)/*	*	*	*		*	17658	1311		4304	*	
12233	10929	12231/12855		12328	10515		12952	12856	4432/12622	11541		(2) 4258/4259 (2)	12326
12596	10929	12231/12855		12328	10515	*	12952	12856	4432			(3) 4258/4259 (2)	*
13363	10929	12231/12855		12328	10515		12952	12856	4432			(3) 4258/4259 (2)	15048
13363	15883	12231/12855		21153	10515		21151		4432			(3) 4258/4259	21154
13363	15883	12231/12855		21153	10515		21151		4432			(3) 4258/4259	21175
13363	15883	12231/12855		21759	10515		21151		4432			(3) 4258/4259	21175
11747	10285	10286		*	10195	10593			10093			4303/4304	
*	*	*	*		9919	*	*		4432	*		4258/12840	
*	10072	11360		*	10515	11389			4432				
12444	10072	11360		12440	10515	11389			4432				
13272	15883	12231		11794	10515	11795			4432/13271			4259/12582	
11374	10944	10931	6333	11370	10515	10182			4432/10093	(2) 1311	14990	(3) 4258/4259 (1)	
12596	10944	12231/12855		12328	10515		12907	12856	4432	9420		(3) 4258/4259 (2)	12926
12367	15883	12231/12855		12328	10515		12303	12856	4432/12622	11541		4259/4258/12305	*
13363	15883	12231/12855		12328	10515		12303	12856	4432			(3) 4258/4259 (2)	19729
13363	15883	12231/12855		17501	10515		12303	12856	4432			(3) 4258/4259 (2)	13362
13363	10944	12231/12855		17501	10515		12228	12856	4432			(3) 4258/4259 (2)	19729
19570	18314	12231/12855		12227	12857		17684	12856	4432			(3) 4258/4259 (2)	15055
19570	18314	12231/12855		12227	12857		19880	12856	4432			(3) 4258/4259 (2)	15055
*	*	*		*	*	*					*		
*	*	*		*	*	*							
*	*	*		*	*	*							
*	*	9484	2075	*	*	*		*		17657	7070		*
*	10285	10286	2075	*	10195	10279			10093	1311	7070	4304	
*	10162	10103	6333	*	*	10094	*		4432	1311		4258/4259	
10289	10285	10197/10286	2075	10596	10195	10279			10093	1311		4303/4304	
*	10072	10171/10103	6333	*	9919	10094	15104		4432/12622	1311		4258/4259	
11873	*	10286	11519	*	10822	10593			10093			12863	
13833	*	10286	11519	*	10822	10593			10093			12863	
*	18663	12231/12855		*	10195		18451	12856	18576		1410-0056	(3) 4258/4259 (1)	
18671	18398	12231			10515	18509	18660		4432		14990	6837/8781	*

ENGINE MANUFACTURER		SHERWOOD NUMBER	PUMP AVAIL	PREPLACEMENT PUMP	PORTS		IMPELLER KIT	MINOR REPAIR KIT	MAJOR REPAIR KIT	SEAL & SEAT/ LIP SEAL	BEARING ASSEMBLY
ENGINE MODEL	ENGINE PART NO.				INLET	OUTLET					
VOLVO PENTA											
		G30-2	O	G30-2B	1"	1"	09959K	23979	12665	12859	(2) 23448
		G85	S		1 1/4"	1 1/4"	10615K	23976	23977	12859	(2) 23448
		P105	S		1 1/4"	1 1/4"	10615K	10615K	19354	18652	8490
6-8 Cyl	3852398	G9901	S		1 1/4"	1"	09959K	23979	12665	12859	(2) 23448
4Cyl	3852399	G9902	O	G9903	1 1/4"	1"	09959K	23979	12665	12859	(2) 23448
4Cyl	3855079	G9903	S		1 1/4"	1"	09959K	23979	12665	12859	(2) 23448
J.H. WESTERBEKE CORP.											
Pilot 10-20		A20	O	F85	3/8" NPT	3/8" NPT	10077K			10927/11237	*
Pilot 10-20	16423	F85	S		1/2" NPT	1/2" NPT	09959K		12221	10514C	(2) 23448
Diesel 4/6 Cyl	16432	F95	O		3/4" NPT	3/4" NPT	10615K	10999	12333	10927	21972
Diesel 6 Cyl	24102	R30G-1-01	P	R30G-1	1/2" NPT	1/2" NPT	10077K	10996	24025	11367	4306
Gov Life Boat	11658	B11	O		1/2" NPT	1/2" NPT	*		*	11367	11365
Gov Life Boat	11353	R10870G-01	S	R10870G	3/4" NPT	3/4" NPT	09959K	10997	12937	10927	4257
Gov Life Boat	24143	H70	O	*	7/8"	7/8"	10077K	*	13366	11628C	
Gov Life Boat	302648	G903	O	G908	1/2" NPT	1/2" NPT	09000K			12859/18806	(2) 23448
Gov Life Boat	42175	G908-01	P	G908	1/2" NPT	1/2" NPT	09000K			12859/18806	(2) 23448
WHITTAKER CORP.											
		S4-1	S		1/2" NPT	1/2" NPT	(2) 00456			10927	4257
YAMAHA											
4.3 V6, 305/350 Chevy	10100000	R991	S		1 1/4"	1 1/4"	09959K	09959K	18655	10927	4257

SHAFT	CAM	GASKET / O-RING	BUSHING	BODY	CAM SCREW	COVER	HOUSING	WEAR PLATE	KEY	PIN	SLINGER	RETAINING RING	PULLEY / GEAR / HUB / ADAPTER
12612	15883	12231/12855		12328	10515	12856	12303	12856	4432	12791		(3) 4258/4259 (2)	12615
12596	10944	12231/12855		12328	10515		12228	12856	4432	9420		(3) 4258/4259 (2)	10769
19308	10944	12231		21378	10515	21120			4432			5126/6837	19275
13363	15883	12231/12855		21153	10515		21151		4432			(3) 4258/4259	21154
13363	15883	12231/12855		21153	10515		21151		4432			(3) 4258/4259	21175
13363	15883	12231/12855		21759	10515		21151		4432			(3) 4258/4259	21175
*	*	*		*	344	10593			10093			4258	
12444	10072	11360		12210	10515	12220			4432				
12226	10929	10931	6333	12225	10515	10182			4432	(2) 1311	7070	(3) 4258/4259 (1)	
11854	10285	10197/10286	2075	10596	10195	10279	15103		10093/13370	(2) 1311		4303/4304 (3)	
11363/*		(2) 5248	*	*	10195	8453	5249			(4) 1311	7269	4304	
10852	15883	10103/10171	6333	10176	9919	10094	15104		4432/12622	(2) 1311		(3) 4258/4259	
11882	10285	11885	11518	*	10195	*			10093		7070	(2) 12863	
*	18663	12231/12855		*	10195		18451	12856	18576		1410-0056	(3) 4258/4259 (1)	
22796	18663	12231/12855		22795	10195		18451	12856	18576		1410-0056	(3) 4258/4259 (1)	
5782/6394		4263/252	6333	6438		11485	11415		4432/12622			(3) 4258/4259 (1)	
18464	15883	12231	6333		10515	18428	18427		12841			(3) 4258/4259 (1)	24791

SERVICE

SHERWOOD NUMBER	PUMP AVAIL	REPLACEMENT PUMP	PORTS		IMPELLER KIT	MINOR REPAIR KIT	MAJOR REPAIR KIT	SEAL & SEAT/ LIP SEAL	BEARING ASSEMBLY	SHAFT
			INLET	OUTLET						
G1	S		1"	1"	09959K	23979	12665	12859	(2) 23448	11877
G1006	S		1"	1"	10615K	10615K	22276	22117/21208	23448	22143
G1006-01	P	G1006	1"	1"	10615K	10615K	22276	22117/21208	23448	22143
G1008-01	P		1"	1"	10615K	10615K	22276	22117/21208	8490	23801
G1009	S		1 1/4"	1 1/4"	10615K	23976	23977	12859/10514C	23448	24628
G1009-01	P	G1009	1 1/4"	1 1/4"	10615K	23976	23977	12859/10514C	23448	24628
G11	S		1/2" NPT	1/2" NPT	09000K			12859	(2) 23448	21578
G1502	O		1 1/2"	1 1/2"	15000K	23980	23256	12966/12966	(2) 23197	23200
G1503	O		1 1/2"	1 1/2"	15000K	23980	23256	12859/12966	(2) 23448	23228
G1503-01	O		1 1/2"	1 1/2"	15000K	23980	23256	12859/12966	(2) 23448	23228
G1503-02	O		1 1/2"	1 1/2"	15000K	23980	23256	12859/12966	(2) 23448	23228
G1503-03	P		1 1/2"	1 1/2"	15000K			24054/12966	(2) 23448	23228
G151	S		1 1/2"	1 1/2"	15000K	23980	23981	12859	(2) 23448	19570
G155	S		1 1/2"	1 1/2"	15000K	23980	23981	12859	(2) 23448	19570
G1801	O		2 1/2"	2"	18000K	21351	21352	19878/19869	24000 Shaft Bearing Assy*	
G1804	O		2 1/2"	2"	18000K	24004	24006	19878/19869	24001 Shaft Bearing Assy*	
G1805	P		2 1/2"	2"	18000K	24023	24024	19878/19869	24000 Shaft Bearing Assy*	
G1806	O		2 1/2"	2 1/2"	18000K	24004	24006	19878/19869	24001 Shaft Bearing Assy*	
G18061-01	P		2 1/2"	2 1/2"	18000K	24004	24006	23837/19869	24001 Shaft Bearing Assy*	
G1807	O	G18071X	2 1/2"	2"	18000K	24023	24024	19878/19869	24001 Shaft Bearing Assy*	
G18071-01	P	G18071X	2 1/2"	2"	18000K	24023	24024	23837/19869	24001 Shaft Bearing Assy*	
G18071X	S		W/O Port Elbow	W/O Port Elbow	18000K	24023	24024	23837/19869	24001 Shaft Bearing Assy*	
G1808	O		3 3/4"	3 3/4"	18000K	24004	24007	19878/23045	24002 Shaft Bearing Assy*	
G18081-01	P		3 3/4"	3 3/4"	18000K	24004	24007	23837/23045	24002 Shaft Bearing Assy*	
G18082-01	P	G18082X	3 3/4"	3 3/4"	18000K	24004	24007	23837/23045	24463 Shaft Bearing Assy*	
G18082X	S		3 3/4"	3 3/4"	18000K	24004	24007	23837/23045	24463 Shaft Bearing Assy*	
G1810-01	P	G1810X	2 1/2"	2"	18000K	24005	24008	23512/23045	24003 Shaft Bearing Assy*	
G1810X	S		W/O Port Elbow	W/O Port Elbow	18000K	24005	24008	23512/23045	24003 Shaft Bearing Assy*	
G1811-01	P	G1816X	2 1/2"	2"	18000K	24005	24008	23512/23045	24003 Shaft Bearing Assy*	
G1814-01	P	G1814X	2 1/2"	2"	24654		24655	24511/23045	24003 Shaft Bearing Assy*	
G1814X	S		W/O Port Elbow	W/O Port Elbow	24654		24655	24511/23045	24003 Shaft Bearing Assy*	
G1815-01	P	G1815X	2 1/2"	W/O Port Elbow	18000K	24753	24754	23512/19869	24003 Shaft Bearing Assy*	
G1815X	S		W/O Port Elbow	W/O Port Elbow	18000K	24753	24754	23512/19869	24003 Shaft Bearing Assy*	
G1816-01	P	G1816X	2 1/2"	W/O Port Elbow	18000K	24760	24761	23512/23045	24003 Shaft Bearing Assy*	
G1816X	S		W/O Port Elbow	W/O Port Elbow	18000K	24760	24761	23512/23045	24003 Shaft Bearing Assy*	
G2	S		1"	1"	09959K	23979	12665	12859	(2) 23448	11877
G2201-01	O		3 3/4"	3 3/4"	22000K	23234	23236	23087/23088	(2)23089	23058
G22011-01	P		3 3/4"	3 3/4"	22000K	23234	*	23906/23088	24464 Shaft Bearing Assy*	
G22012-01	P	G22012X	3 3/4"	3 3/4"	22000K	23234	*	23906/23088	24465 Shaft Bearing Assy*	
G22012X	S		3 3/4"	3 3/4"	22000K	23234	*	23906/23088	24465 Shaft Bearing Assy*	
G2601-01	P	G2603X	2 1/2"	W/O Port Elbow	26000K	24227	24228	23837/19869	24223 Shaft Bearing Assy*	
G2601X	O	G2603X	W/O Port Elbow	W/O Port Elbow	26000K	24227	24228	23837/19869	24223 Shaft Bearing Assy*	
G2602-01	P	G2603X	2 1/2"	W/O Port Elbow	26000K	24227	24228	23837/19869	24223 Shaft Bearing Assy*	
G2603-01	P	G2603X	2 1/2"	W/O Port Elbow	26000K	24841	24842	23837/19869	24223 Shaft Bearing Assy*	
G2603X	S	G2603X	W/O Port Elbow	W/O Port Elbow	26000K	24841	24842	23837/19869	24223 Shaft Bearing Assy*	
G2605-01	P	G2603X	2 1/2"	W/O Port Elbow	26000K	24841	24842	23837/19869	24223 Shaft Bearing Assy*	
G3	S		1-1/4"	1-1/4"	10615K	23976	23977	12859	(2) 23448	11877
G4	S		1-1/4"	1-1/4"	10615K	23976	23977	12859	(2) 23448	11877
G701-01	O	G702	1"	1"	10077K		22784	24934/21751	(2) 23448	22769
G702	S		1"	1"	10077K			24934/21751	(2) 23448	22769
G702-01	P	G702	1"	1"	10077K			24934/21751	(2) 23448	22769
G8	O		1-1/4"	1-1/4"	10615K	23976	23977	12859	(2) 23448	11877
G8001	S		3/8" NPT	3/8" NPT	8000K			23459	(2) 23323	23445
G8001-01	P	G8001	3/8" NPT	3/8" NPT	8000K			23459	(2) 23323	23445
G8002	S		3/8" NPT	3/8" NPT	8000K			23459	(2) 23448	23679
G8002-01	P	G8002	3/8" NPT	3/8" NPT	8000K			23459	(2) 23448	23679
G907	O	G907P	3/8" NPT	3/8" NPT	09000K			22546	(2) 23448	21861
G907P	S		3/8" NPT	3/8" NPT	09000K			22546	(2) 23448	24124
G909-01	P		3/8" NPT	3/8" NPT	09000K			22546	(2) 23448	24171
G910P	S		3/8" NPT	3/8" NPT	09000K			22546	(2) 23448	24569
G910P-01	P	G910P	3/8" NPT	3/8" NPT	09000K			22546	(2) 23448	24569
GC1	S		1 1/2"	1 1/2"	15000K	23980	23981	12859/10514C	(2) 23448	21069
GC1-01	P	GC1	1 1/2"	1 1/2"	15000K	23980	23981	12859/10514C	(2) 23448	21069
GC4	O	GC5	1 1/2"	1 1/2"	15000K	23980	23981	12859/10514C	(2) 23448	21069

* Assembly includes bearings pressed onto the shaft along with the appropriate spacers, washers and retaining rings.

Other OEM and General Service Pumps

CAM	GASKET / O-RING	BUSHING	BODY	CAM SCREW	COVER	HOUSING	WEAR PLATE	KEY	PIN	SLINGER	HUB/ ADAPT	RETAINING RING	PULLEY / GEAR
15883	12231/12855		12227	10515		12303	12856	04432/12622				(3) 4258/4259 (2)	
10929	(2) 12231	6333	22141	10515	22140	21150	22142	4432	(4) 21056			(3) 4258/4259 (2)	
10929	(2) 12231	6333	22141	10515	22140	21150	22142	4432	(4) 21056			(3) 4258/4259 (2)	
10929	(2) 12231	6333	23798	10515	22140	21150	22142	4432	(4) 21056			04258/05126/06837	
10944	12231/12855		24624	10515C		12228	12856	4432				(1)4258/(1)4259/(2)14161	
10944	12231/12855		24624	10515C		12228	12856	4432				(1)4258/(1)4259/(2)14161	
18663	12231/12855		12227	10195		18451	12856	12622/18576				(3) 4258/4259 (2)	
	12231		22635		21173	*	22836	4432				(2) 4258/4259 (1)	23870
	12231		23231		21173	23230	22836	4432				(2) 4258/4259 (1)	23870
	12231		23231		21173	23230	22836	4432				(2) 4258/4259 (1)	23870
	12231		23231		21173	23230	22836	4432				(2) 4258/4259 (1)	
	12231		23231		21173	23230	22836	4432				(2) 4258/4259 (1)	23870
18314	12231/12855		12227	12857		17684	12856	4432				(3) 4258/4259 (2)	
18314			12227	12857		19880	12856	4432				(2) 4258/4259 (3)	
19829	19879		19827		19837	19828	19836			19868		(2) 19762/19867 (1)	
(2) 21533	(2) 21561		*		19837	21565	19836		21566	19868		(2) 19762/19867 (1)	
(2) 21106	(2) 21561		22125		19837	21829	19836		21566	19868		(2) 19762/19867 (1)	
(2) 21533	(2) 21561		21986		19837	21829	19836		21566	19868		(2) 19762/19867 (1)	
(2) 21533	(2) 21561		21986		19837	21829	19836		21566	19868		(2) 19762/19867 (1)	
(2) 21106	(2) 21561		21827		19837	21829	19836		21566	19868		(2) 19762/19867 (1)	
(2) 21106	(2) 21561		21827		19837	21829	19836		21566	19868		(2) 19762/19867 (1)	
(2) 21533	(2) 21561		22412		19837	22762	19836	22791	21566	19868		(2) 19762/19867 (1)	22789
(2) 21533	(2) 21561		22412		19837	22762	19836	22791	21566	19868		(2) 19762/19867 (1)	22789
(2) 21533	(2) 21561		23916		19837	22762	19836	22791	21566	19868		(2) 19762/19867 (1)	22789
(2) 21533	(2) 21561		23916		19837	22762	19836	22791	21566	19868		(2) 19762/19867 (1)	22789
(2) 21106	1720-0212		23396		19837	23523	19836		21566	19868		(2) 19762/19867 (1)	
(2) 21106	1720-0212		23396		19837	23523	19836		21566	19868		(2) 19762/19867 (1)	
(2) 21106	1720-0212		24174		19837	23523	19836		21566	19868		(2) 19762/19867 (1)	
(2) 21106	1720-0212		23396		19837	23523	19836		21566	19868		(2) 19762/19867 (1)	
(2) 21106	1720-0212		23396		19837	23523	19836		21566	19868		(2) 19762/19867 (1)	
(2) 21533	1720-0212		24174		19837	23523	19836		21566	19868		(2) 19762/19867 (1)	
(2) 21533	1720-0212		24174		19837	23523	19836		21566	19868		(2) 19762/19867 (1)	
(2) 21533	1720-0212		24174		19837	23523	19836		21566	19868		(2) 19762/19867 (1)	
(2) 21533	1720-0212		24174		19837	23523	19836		21566	19868		(2) 19762/19867 (1)	
15883	12231/12855		12227	10515		11903	12856	04432/12622				(3) 4258/4259 (2)	
22453	23111		23056		23113	23057	23112		21566			1810-0012/23091/23115	23181
24160	23111		23056		23113	24229	23112		21566			1810-0012/23091/23115	23181
24160	23111		23919		23113	24159	23112		21566			1810-0012/23091/23115	23181
24160	23111		23919		23113	24159	23112		21566			1810-0012/23091/23115	23181
24075	19879		24102	19714	24074	24072	24073			24079		(2) 19762/19867 (1)	24083
24075	19879		24102	19714	24074	24072	24073			24079		(2) 19762/19867 (1)	24083
24075	19879		24102	19714	24074	24072	24073			24079		(2) 19762/19867 (1)	24083
24075	19879		24102	19714	24074	24072	24073			24079		(2) 19762/19867 (1)	24083
24075	19879		24102	19714	24074	24072	24073			24079		(2) 19762/19867 (1)	24083
24075	19879		24102	19714	24074	24072	24073			24079		(2) 19762/19867 (1)	24083
10944	12231/12855		12227	10515		12228	12856	04432/12622				(3) 4258/4259 (2)	
10944	12231/12855		12227	10515		12907	12856	04432/12622				(3) 4258/4259 (2)	
	21303/22770		22685		22767	22688	22768	10093				4258/4259	
	21303/22770		24525			24524	24526	10093				4258/4259	
	21303/22770		24525			24524	24526	10093				4258/4259	
10929	12231/12855		18075	10515		18154	12856	04432/12622				(3) 4258/4259 (2)	
	23447		23354		23366	24100						(1) 23325/23443 (1)	
	23447		23354		23366	24100						(1) 23325/23443 (1)	
	23447		23678		23366	24100						(1) 04258/04259 (1)	23680
	23447		23678		23366	24100						(1) 04258/04259 (1)	23680
18663	19964			10195	24125	24627		18576				(2) 4258/4259	
18663	19964			10195	24125	24627		18576				(2) 4258/4259	21859
18663	19964			10195	24125	21862		13777				(2) 4258/4259	
18663	19964			10195	24125	24627		18576				(2) 4258/4259	24589
18663	19964			10195	24125	24627		18576				(2) 4258/4259	24589
18398	12231/12855		14160	10515		17684	12856	4432		18681		4258/14161/4259 (2)	14184
18398	12231/12855		14160	10515		17684	12856	4432		18681		4258/14161/4259 (2)	14184
18398	12231/12855		14160	10515		17684	12856	4432		19387		4258/14161/4259 (2)	14184

SERVICE

SHERWOOD NUMBER	PUMP AVAIL	REPLACEMENT PUMP	PORTS		IMPELLER KIT	MINOR REPAIR KIT	MAJOR REPAIR KIT	SEAL & SEAT/ LIP SEAL	BEARING ASSEMBLY	SHAFT
			INLET	OUTLET						
GC5	S		1 1/2"	1 1/2"	15000K	23980	23981	12859/10514C	(2) 23448	19843
GC5-01	P	GC5	1 1/2"	1 1/2"	15000K	23980	23981	12859/10514C	(2) 23448	19843
GP8001-01	O	G8001	3/8" NPT	3/8" NPT	8000K			23459	(2) 23323	23445
GP8002-01	O	G8002	3/8" NPT	3/8" NPT	8000K			23459	(2) 23448	23679
M71	S		1 1/4"	1 1/4"	10615K	23976	23977	12859/10514C	(2) 23448	14159
M71-01	P	M71	1 1/4"	1 1/4"	10615K	23976	23977	12859/10514C	(2) 23448	14159
P105-01	P	P105	1 1/4"	1 1/4"	10615K	10615K	19354	18652	(2) 08490	19308
P105	S		1 1/4"	1 1/4"	10615K	10615K	19354	18652	(2) 08490	19308
P109-01	P	P110	1 1/4"	1 1/4"	10615K	10615K	19354	18652	(2) 08490	19308
P110	S		1 1/4"	1 1/4"	10615K	10615K	19354	18652	(2) 08490	19308
P1012-01	P	P1014	1 1/4"	1 1/4"	10615K	19301	19300	12859	(2) 23448	19293
P1014	S		1 1/4"	1 1/4"	10615K	19301	19300	12859	(2) 23448	19293
P1015-01	P	P1014	1 1/4"	1 1/4"	10615K	19301	19300	12859	(2) 23448	19293
P1016-01	P	P1016	1 1/2"	1 1/2"	10615K	23976	25009	12859	(2) 23448	24885
P1016	S		1 1/2"	1 1/2"	10615K	23976	25009	12859	(2) 23448	24885
P171	O	P176X	1 3/4"	1 3/4"	17000K	23973	23975	15955	(2) 15951	*
P1710-02	P	P1710A	W/O Port Elbow	W/O Port Elbow	17000K	23973	23975	23799/21776		24469 Shaft Bearing Assy
P1710A	S		W/O Port Elbow	W/O Port Elbow	17000K	24576	24577	23799/21776		24469 Shaft Bearing Assy
P1710X	O	P1710A	W/O Port Elbow	W/O Port Elbow	17000K	23973	23975	15955/21776		24469 Shaft Bearing Assy
P1711	O	P1719X	W/O Port Elbow	W/O Port Elbow	17000K	23972	23974	15955/19674	(2) 15951	19345
P1712	O	P1716A	1 3/4"	1 3/4"	17000K	23972	23974	15955/19674	(2) 15951	16046
P1716B-01	P	P1716A	2"	1 3/4"	17000K	23972	23974	15955/19674		24470 Shaft Bearing Assy
P1716B-02	P	P1716A	2"	1 3/4"	17000K	23972	23974	23799/19674		24470 Shaft Bearing Assy
P1716A	S		2"	1 3/4"	17000K	23972	23974	23799/24250		24470 Shaft Bearing Assy
P1716X	S	P1716A	2"	1 3/4"	17000K	23972	23974	15955/19674		24470 Shaft Bearing Assy
P1719-01	P	P1719X	W/O Port Elbow	W/O Port Elbow	17000K	23972	23974	15955/19674	(2) 15951	19345
P1719F-01	O	P1719X	2"	2"	17000K	23972	23974	15955/19674	(2) 15951	19345
P1719X	S		W/O Port Elbow	W/O Port Elbow	17000K	23972	23974	15955/19674	(2) 15951	19345
P172	O	P1710A	1 3/4"	1 3/4"	17000K	23973	23975	15955/15950	(2) 15951	19620
P1722B-01	P	P1722A	2"	1 3/4"	17000K	23972	23974	15955/19674		24470 Shaft Bearing Assy
P1722B-02	P	P1722A	2"	1 3/4"	17000K	23972	23974	23799/19674		24470 Shaft Bearing Assy
P1722A	S		2"	1 3/4"	17000K	23972	23974	23799/24250		24470 Shaft Bearing Assy
P1722X	S	P1722A	2"	1 3/4"	17000K	23972	23974	15955/19674		24470 Shaft Bearing Assy
P1726	P	P1732A	W/O Port Elbow	W/O Port Elbow	17000K	23973	23975	15955/21776		24469 Shaft Bearing Assy
P1726X	O	P1732A	W/O Port Elbow	W/O Port Elbow	17000K	23973	23975	15955/21776		24469 Shaft Bearing Assy
P1726TC-02	P		W/O Port Elbow	W/O Port Elbow	17000K			23799/21776		24469 Shaft Bearing Assy
P1727A	S		W/O Port Elbow	W/O Port Elbow	17000K	24578	24579	23799/24250		24470 Shaft Bearing Assy
P1727FB-01	P	P1727A	2"	1 3/4"	17000K	23972	23974	15955/19674		24470 Shaft Bearing Assy
P1727FB-02	P	P1727A	2"	1 3/4"	17000K	23972	23974	23799/19674		24470 Shaft Bearing Assy
P1727X	O	P1727A	W/O Port Elbow	W/O Port Elbow	17000K	23972	23974	15955/19674		24470 Shaft Bearing Assy
P173	O	P1722A	1 3/4"	1 3/4"	17000K	23972	23974	15955/19674	(2) 15951	16046
P1730A	S		W/O Port Elbow	W/O Port Elbow	17000K	24578	24579	23799/24250		24470 Shaft Bearing Assy
P1730-02	P	P1730A	W/O Port Elbow	W/O Port Elbow	17000K	23972	23974	23799/19674		24470 Shaft Bearing Assy
P1730F-01	P	P1730A	2"	1 3/4"	17000K	23972	23974	15955/19674		24470 Shaft Bearing Assy
P1730F-02	P	P1730A	2"	1 3/4"	17000K	23972	23974	23799/19674		24470 Shaft Bearing Assy
P1730X	O	P1730A	W/O Port Elbow	W/O Port Elbow	17000K	23972	23974	15955/19674		24470 Shaft Bearing Assy
P1731F-01	P	P1730A	2"	1 3/4"	17000K	23972	23974	15955/19674		24470 Shaft Bearing Assy
P1731F-02	P	P1730A	2"	1 3/4"	17000K	23972	23974	23799/19674		24470 Shaft Bearing Assy
P1732A	S		W/O Port Elbow	W/O Port Elbow	17000K	24576	24577	23799/21776		24469 Shaft Bearing Assy
P1732-02	P	P1732A	W/O Port Elbow	W/O Port Elbow	17000K	23973	23975	23799/21776		24469 Shaft Bearing Assy
P1732X	O	P1732A	W/O Port Elbow	W/O Port Elbow	17000K	23973	23975	23799/21776		24469 Shaft Bearing Assy
P1733F-01	P	P1733X	2"	2"	17000K	23972	25038	15955/24017	(2) 15951	24015
P1733X	S		W/O Port Elbow	W/O Port Elbow	17000K	23972	25038	15955/24017	(2) 15951	24015
P176-02	P	P176X	1 1/2" NPT	1 3/4"	17000K	23973	23975	23799	(2) 15951	19620
P176X	S		1 1/2" NPT	1 3/4"	17000K	23973	23975	15955	(2) 15951	19620
P2701-01	O	P2701X	2"	2"	27000K	24580	24581	23799		24306 Shaft Bearing Assy
P2701X	S		W/O Port Elbow	W/O Port Elbow	27000K	24580	24581	23799		24306 Shaft Bearing Assy
P2702-01	O	P2701X	W/O Port Elbow	W/O Port Elbow	27000K	24580	24581	23799		24306 Shaft Bearing Assy
P2704-01	P	P2701X	2"	2"	27000K	24580	24581	23799		24306 Shaft Bearing Assy
P2705-01	P	P2701X	2"	2"	27000K	24580	24581	23799		24306 Shaft Bearing Assy
P2706-01	P	P2701X	2"	2"	27000K	24580	24581	23799		24306 Shaft Bearing Assy
R102	S		1" NPT	1" NPT	10615K	10999	11068	10927	4257	18502
R30G	S		1/2" NPT	1/2" NPT	10077K	10996	24025	11367	4306	10289
R50G	S		3/4" NPT	3/4" NPT	09959K	10997	12937	10927	4257	10175

* Assembly includes bearing pressed onto the shaft along with the appropriate spacers, washers and retaining rings.

CAM	GASKET / O-RING	BUSHING	BODY	CAM SCREW	COVER	HOUSING	WEAR PLATE	KEY	PIN	SLINGER	HUB/ ADAPT	RETAINING RING	PULLEY / GEAR
18398	12231/12855		19907	10515		17684	12856	4432			21700	(2) 4258/4259	19884
18398	12231/12855		19907	10515		17684	12856	4432			21700	(2) 4258/4259	19884
	23447		23354		23366	23352						23325/23443	
	23447		23678		23366	23352						04258/04259	23680
10944	12231/12855		14160	10515		12228	12856	4432			18681	4258/14161/4259 (2)	14184
10944	12231/12855		14160	10515		12228	12856	4432			18681	4258/14161/4259 (2)	14184
10944	12231			10515	23912	21378		4432				5126/6837	
10944	12231			10515	21120	21378		4432				5126/6837	
10944	12231			10515	23912	23791		4432			23770	05126/06837	
10944	12231			10515	21120	23791		4432			23770	05126/06837	
10944	19251		19294	10515	23946		19295	4432			97176	(2) 4258/4259 (1)	
10944	12231			10515	21120	24107	19295	4432			97176	(2) 4258/4259 (1)	
10944	12231			10515	23912	24107	19295	4432			97176	(2) 4258/4259 (1)	
10929	12231			24884	24887	24882	19295	4432		24930	24883	(2) 4258/4259 (1)	
10929	12231			24884	24887	24882	19295	4432		24930	24883	(2) 4258/4259 (1)	
18271	15945			19673	18742	*	18441	15948				(3) 15952/15942(1)	
18271	15945			19714	18742	19683	18441	19667			19699	(3) 15952/15942 (1)	
18271	15945			19714	18742	24161	24162	19667		24156	19699	(3) 15952/15942 (1)	
18271	15945			19714	18742	19683	18441	19667			19699	(3) 15952/15942 (1)	
18271	15945			19714	18742	*	18441	19209			*	(3) 15952	
18271	15945			19673	18742	18385	18441	19209			*	(3) 15952/15942 (1)	14184
18271	21570/15945			19714	18742	19630	18441	19667			19727	(3) 15952	19885
18271	21570/15945			19714	18742	19630	18441	19667			19727	(3) 15952	19885
18271	21570/15945			19714	18742	19630	18441	19667		24156	19727	(3) 15952	19885
18271	21570/15945			19714	18742	19630	18441	19667			19727	(3) 15952	19885
18271	15945			19714	18742	19732	18441	19667		19712	19700	(3) 15952	
18271	15945			19714	18742	19732	18441	19667		19712	19700	(3) 15952	
18271	15945			19673	18742	*	18441	15948				(3) 15952/15942 (1)	
18271	21570/15945			19714	18742	19630	18441	19667			19955	(3) 15952	19885
18271	21570/15945			19714	18742	19630	18441	19667			19955	(3) 15952	19885
18271	21570/15945			19714	18742	19630	18441	19667		24156	19955	(3) 15952	19885
18271	21570/15945			19714	18742	19630	18441	19667			19955	(3) 15952	19885
21318	15945			19714	18742	19683	18441	19667			19699	(3) 15952/15942 (1)	
21318	15945			19714	18742	19683	18441	19667			19699	(3) 15952/15942 (1)	
22821	15945			19714	22819	22820	22818	19667			19699	(3) 15952/15942 (1)	
18271	21570/15945			19714	18742	24176	24162	19667		24156	21205	(3) 15952	19885
18271	21570/15945			19714	18742	24176	18441	19667			21205	(3) 15952	19885
18271	21570/15945			19714	18742	24176	18441	19667			21205	(3) 15952	19885
18271	21570/15945			19714	18742	24176	18441	19667			21205	(3) 15952	19885
18271	15945			10515	18742	18385	18441	19209			*	(3) 15952/15942 (1)	14184
18271	21570/15945			19714	18742	24176	24162	19667		24156	21985	(3) 15952	22495
18271	21570/15945			19714	18742	24176	18441	19667			21985	(3) 15952	22495
18271	21570/15945			19714	18742	24176	18441	19667			21985	(3) 15952	22495
18271	21570/15945			19714	18742	24176	18441	19667			21985	(3) 15952	22495
18271	21570/15945			19714	18742	24176	18441	19667			21985	(3) 15952	22495
18271	21570/15945			19714	18742	24176	18441	19667			21985	(3) 15952	22495
21318	15945			19714	18742	24161	24162	19667		24156	19699	(3) 15952/15942 (1)	
21318	15945			19714	18742	19683	18441	19667			19699	(3) 15952/15942 (1)	
21318	15945			19714	18742	19683	18441	19667			19699	(3) 15952/15942 (1)	
18271	15945			19714	18742	19732	18441	19667			24016	(3) 15952	
18271	15945			19714	18742	19732	18441	19667			24016	(3) 15952	
18271	15945			10515	18742	19015	18441	19667				(3) 15952/15942(1)	
18271	15945			10515	18742	19015	18441	19667				(3) 15952/15942(1)	
18271	15945			19714	18742	24161	24162				24144	(2) 15952/15942 (1)	
18271	15945			19714	18742	24161	24162				24879	(2) 15952/15942 (1)	
18271	15945			19714	18742	24161	24162				24144	(2) 15952/15942 (1)	
18271	15945			19714	18742	24161	24162				24879	(2) 15952/15942 (1)	
18271	15945			19714	18742	24161	24162				24879	(2) 15952/15942 (1)	
18271	15945			19714	18742	24161	24162				24879	(2) 15952/15942 (1)	
10929	10931	6333	18501	10515	10182			(2)4432	(2) 1311			(3) 4258/4259	
10285	10197/10286	2075	10596	10195	10279	15103		10093	(2) 1311			4303/4304 (3)	
15883	10103/10171	6333	10176	9919	10094	15104		4432	(2) 1311			(3) 4258/4259	

09959, 10615, and 15000 G Series Technical Guide

Assembly/Disassembly Instructions

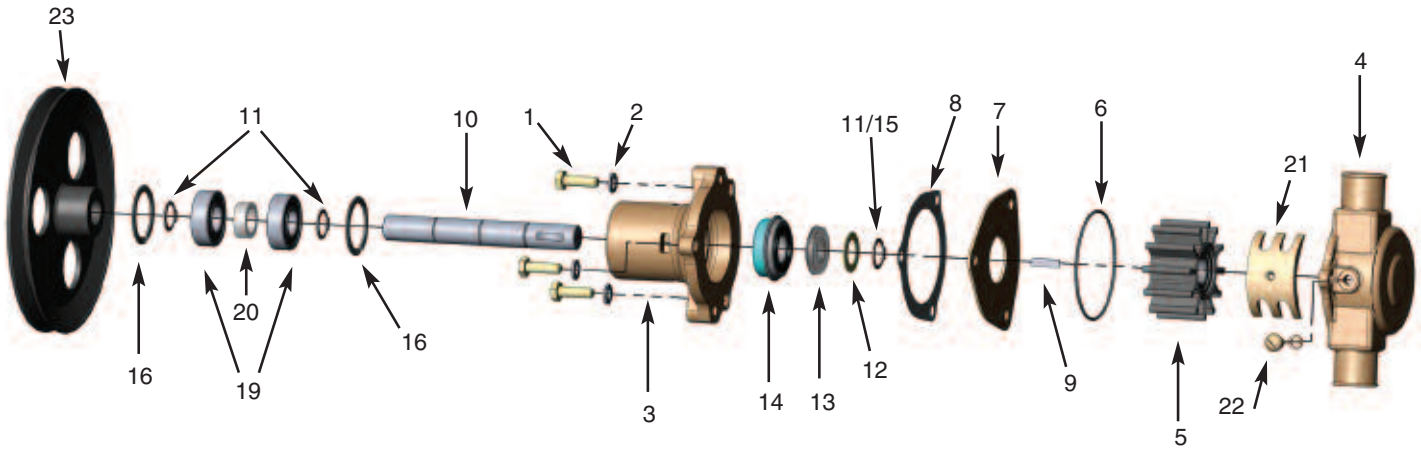

The following assembly/disassembly procedures apply to all G Series pumps. Deviations from pump to pump are primarily a result of different methods of drive and mounting.

Disassembly:

- A. Remove the screws (1) and lockwashers (2) that hold the body (3) and housing (4) together.
- B. The housing assembly including the impeller (5) can be removed from the body assembly, along with the o-ring (6), spacer plate (7) and gasket (8).
- C. Remove the woodruff key (9) from the shaft (10). If the shaft is to be used again, and if it is put in a vise, always use lead over the jaws of the vise so that the shaft is not damaged.
- D. Remove the retaining ring (11 or 15) from the shaft (impeller end). The shoulder washer (12) and seat assembly (13) can now be removed.
- E. From the drive end of the pump (pulley end, hub end, shaft end), remove retaining ring, remove pin (17), remove woodruff key (18) and loosen setscrew if used. **Note:** If the pulley (23) or hub (24) is pressed on the shaft, it will be necessary to locate a support directly between the pump body and pulley or hub as close to the shaft as possible. Press the shaft out of the pulley or hub. Make sure the body is free and not supported.
- F. For the M71, GC1, GC4 and GC5, remove the two bolts that hold the aluminum adapter onto the bearing body. Pull the adapter off of the bearing body and press the lip seal out of the adapter.
- G. Remove the large internal retaining ring (16) from the body at the end of the bearing.
- H. Support the body, and press the shaft, bearings (19), spacer (20) and retaining rings (11) out through the bearing or pulley end of the body.
- I. The seal assembly (14) is pressed into the body. It can be removed by pushing a tool through the bearing end and up against the metal or back side of the seal. **Note:** On some pumps, there is a spacer located between the pulley (hub) and bearing on the shaft. On other pumps, the bearings are positioned on the shaft with a retaining ring on each end. Support the bearings on the inner race, and push the shaft out of the bearings.

Assembly:

- A. When assembling the cam (21), put Permatex #1 on the backside of the cam and the screw (22) that retains the cam. Wipe off any Permatex that gets into the impeller cavity.
- B. Assemble a retaining ring (11) on the shaft into the second groove from the impeller end. Push the ball bearing (19) over the shaft (10). Press on the inner race of the bearing. Push the bearing up against the retaining ring. (Push the bearing on from the pulley or drive end, except for M71, GC1, GC4 and GC5 pumps). Assemble a spacer and then the second ball bearing. Assemble the second retaining ring over the shaft and up against the ball bearing, if required.
- C. There is a large internal retaining ring (16) located in the body that provides a shoulder for the bearings (approximately 1.38" from the bearing end of the body). If it has been removed, it must be inserted at this time.
- D. Press the mechanical seal (14) into the body from the impeller end. Make sure that seal is pressed in square. A tool should be used to assure proper assembly.

09959, 10615, and 15000 G Series Technical Guide *(continued)*

- E. Push the bearing and shaft assembly into the body using care not to cock the bearing. A tool is recommended that will give you uniform pressure on the bearing outer race. Lock the bearing in place with the large internal retaining ring.
- F. Assemble the seat assembly (13), shoulder washer (12) and retaining ring (11 or 15) over the shaft from the impeller end. Locate the white ceramic surface against the seal – Do not damage (scratch) the white ceramic surface of the seat, or the seal and seat assembly might leak. Lubricate the rubber part of the seat and use a tool for ease of assembly.
- G. For the M71, GC1, GC4 and GC5, press a new lip seal into the aluminum adapter (with the metal backing ring away from the engine). Replace the adapter onto the bearing body. Assemble the lockwashers and bolts to the adapter. Torque the bolts to 24 ft.-lbs.
- H. While supporting the shaft, press the pulley/gear (23) or hub (24) onto the shaft. Secure pulley/hub with pin (17) or key (18) and retaining ring or setscrew as needed.
- I. Press the woodruff key (9) into the shaft. Make sure the stainless steel key is used at this location.
- J. Assemble the impeller (5) into the housing (4). **Note:** Do not use petroleum-based fluid to lubricate the impeller.
- K. Place the o-ring (6) in the groove in the housing (4). A small dab of grease will help hold it in position until the housing to body screws are tightened. Assemble the gasket (8) and spacer plate (7) on the body (3), and line up the screw holes.
- L. Replace the lockwashers (2), and tighten the screws (1). Torque the screws to 84 in.-lbs
- M. After installation, inspect the pump seal, lip seal, body, housing and cam areas for leaks.

09959 Chart

		Sherwood #	G15	G21	G30-2B	G30-2	G9901	G9903	J70	K75B
		Engine Manufacturer	Chris Craft		Chris Craft	Chris Craft	Volvo/OMC	Volvo/OMC	Commander	
		Engine Model	350		350	350	6&8 Cyl	4 Cyl	302&351	
Item		QTY			16.80-18346	16.80-18346	3852398	3855079	CM1-10-610	
1	Screw	3	12857	12857	12857	12857	12857	12857	12857	12857
2	Lockwasher	3	12710	12710	12710	12710	21757	21757	12710	12710
3	Body	1	12324	12328	19784	12328	21153	21759	12328	19948
4	Housing	1	12303	12303	12303	12303	21151	21151	12303	13793
5	Impeller	1	9959	9959	9959	9959	9959	9959	9959	9959
6	O-ring	1	12231	12231	12231	12231	12231	12231	12231	12231
7	End Plate	1	12856	12856	12856	12856	12856	12856	12856	12856
8	Gasket	1	12855	12855	12855	12855	12855	12855	12855	12855
9	Key	1	4432	4432	4432	4432	4432	4432	4432	4432
10	Shaft	1	12233	13363	12612	12612	13363	13363	13274	13363
11	Retaining Ring (Ext)	2/3	4258	4258	4258	4258	4258	4258	4258	4258
12	Washer	1	4264	4264	4264	4264	4264	4264	4264	4264
15	Retaining Ring (Ext)	1	12305							
16	Retaining Ring (Int)	2	4259	4259	4259	4259	4259	4259	4259	4259
17	Pin	1			12791	12791				
18	Key	1	12622						12622	
19	Ball Bearing	2	23448	23448	23448	23448	23448	23448	23448	23448
20	Spacer	1	5133	5133	5133	5133	5133	5133	5133	5133
21	Cam	1	15883	15883	15883	15883	15883	15883	15883	15883
22	Cam Screw	1	10515	10515	10515	10515	10515	10515	10515	10515
23	Drive Pulley or Gear	1	12323	19729			21154	21175	13429	
24	Hub	1			12615	12615				13795
13/14	Water Seal/Seat Assy	1	12859	12859	12859	12859	12859	12859	12859	12859
	Minor Repair Kit		23979	23979	23979	23979	23979	23979	23979	23979
	Major Repair Kit		12665	12665	12665	12665	12665	12665	12665	12665

09959, 10615, and 15000 G Series Technical Guide *(continued)*

10615 Chart

Sherwood #		G5	G7	G7B	G45-1	G46	G50	G55-2	K90	L10B	M71
Engine Manufacturer		Chrys.	Chrys.	Chrys.	Chris Craft	OMC	Chrys.		Isuzu		
Engine Model		318, 340	318, 360	318, 360	454	V8 Chevy	318, 340		4,6 Cyl Diesel		
Item	QTY	3675763	4142878	4142878	16.80-18347	985096	3619212		X-26-230-1023		
1	Screw	3	12857	12857	12857	12857	12857	12857	12857	12857	12857
2	Lockwasher	3	12710	12710	12710	12710	12710	12710	12710	12710	12710
3	Body	1	12227	12227	19789	12328	12328	12227	12328	12227	19948
4	Housing	1	12228	12952	12952	12228	12952	12228	12907	12228	13899
5	Impeller	1	10615	10615	10615	10615	10615	10615	10615	10615	10615
6	O-ring	1	12231	12231	12231	12231	12231	12231	12231	12231	12231
7	End Plate	1	12856	12856	12856	12856	12856	12856	12856	12856	12856
8	Gasket	1	12855	12855	12855	12855	12855	12855	12855	12855	12855
9	Key	1	4432	4432	4432	4432	4432	4432	4432	4432	4432
10	Shaft	1	12233	13363	13363	12612	13363	12233	12596	12596	13363
11	Retaining Ring (Ext)	2/3	4258	4258	4258	4258	4258	4258	4258	4258	4258
12	Washer	1	4264	4264	4264	4264	4264	4264	4264	4264	4264
15	Retaining Ring (Ext)	1	12305					12305			
16	Retaining Ring (Int)	2	4259	4259	4259	4259	4259	4259	4259	4259	4259
17	Pin	1	11541			12791		11541	9420		
18	Key	1	12622					12622			
19	Ball Bearing	2	23448	23448	23448	23448	23448	23448	23448	23448	23448
20	Spacer	1	5133	5133	5133	5133	5133	5133	5133	5133	5133
21	Cam	1	10944	10929	10929	10944	10929	10944	10944	10944	10944
22	Cam Screw	1	10515	10515	10515	10515	10515	10515	10515	10515	10515
23	Drive Pulley or Gear	1	12326	15055	15055		15048	12323		14992	14184
24	Hub	1				12615			12926		13795
13/14	Water Seal/Seat Assy	1	12859	12859	12859	12859	12859	12859	12859	12859	12859
	Oil Seal	1									10514
	Minor Repair Kit		23976	23976	23976	23976	23976	23976	23976	23976	23976
	Major Repair Kit		23977	23977	23977	23977	23977	23977	23977	23977	23977

15000 Chart

Sherwood #		GC1	GC4	GC5	G151	G155	G157	G1503
Item	QTY							
1	Screw	3	12857	12857	12857	12857	12857	12857
2	Lockwasher	3	12710	12710	12710	12710	12710	12710
3	Body	1	14160	14160	19907	12227	12227	23231
4	Housing	1	17684	17684	17684	17684	19880	17684
5	Impeller	1	15000	15000	15000	15000	15000	15000
6	O-ring	1	12231	12231	12231	12231	12231	12231
7	End Plate	1	12856	12856	12856	12856	12856	22836
8	Gasket	1	12855	12855	12855	12855	12855	12855
9	Key	1	4432	4432	4432	4432	4432	4432
10	Shaft	1	21069	21069	19843	19570	19570	21231
11	Retaining Ring (Ext)	2/3	4258	4258	4258	4258	4258	4258
12	Washer	1	4264	4264	4264	4264	4264	4264
15	Retaining Ring (Ext)	1	14161	14161				
16	Retaining Ring (Int)	2	4259	4259	4259	4259	4259	4259
19	Ball Bearing	2	23448	23448	23448	23448	23448	23448
20	Spacer	1	5133	5133	19906	5133	5133	5133
21	Cam	1	18398	18398	18398	18314	18314	18314
22	Cam Screw	1	10515	10515	10515	10515	10515	10515
23	Drive Pulley or Gear	1	14184	14184	14184	15055	15055	
24	Hub	1					21232	
13/14	Water Seal/Seat Assy	1	12859	12859	12859	12859	12859	12859/12966
	Oil Seal	1	10514	10514	10514			12966
	Cover							21173
	Minor Repair Kit		23980	23980	23980	23980	23980	23980
	Major Repair Kit		23981	23981	23981	23981	23981	23256

R Series Technical Guide

Assembly/Disassembly Instructions

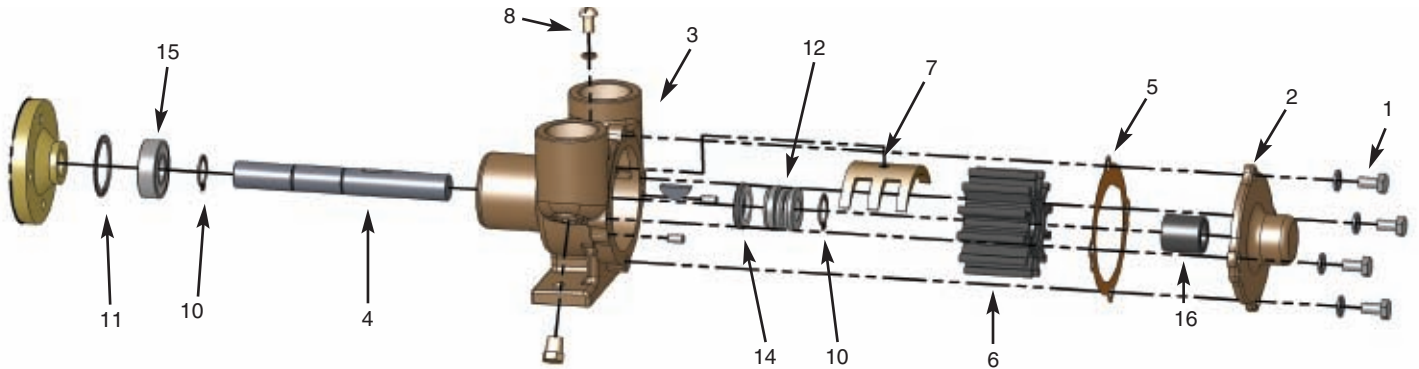

The following assembly/disassembly procedures apply to all R Series pumps. Deviations from pump to pump are primarily a result of different methods of drive and mounting. Pump numbers can be found on the tag or stamped on the pedestal base of the pump.

Disassembly:

- A. Remove the screws (1) and lockwashers that hold the cover to the body (3). Pull the cover and bushing assembly (2) off the drive shaft (4).
- B. Remove the vellum gasket (5). Sherwood recommends replacing the gasket each time the pump is assembled, however, if you plan to use the same gasket, it should be submerged in water until pump is reassembled. If gasket dries, it will shrink.
- C. The impeller (6) can now be removed by using pliers and grasping a vane on one side, then the other, alternating positions and gently pulling. Make sure you have a good grip on each vane so the pliers will not slip and damage the impeller.
- D. The cam (7) can be removed by removing the screw (8) that goes down through the top of the body between the intake and discharge ports.
- E. Remove the two screws (18) and lockwashers from the bearing housing (9) on the drive shaft end of the housing. This will allow you to remove the bearing housing, seal assembly, and shaft from the body.
- F. Remove the woodruff key from the shaft. If the shaft is to be used again and if it is put in a vise, always use lead over the jaws of the vise so that the shaft is not damaged.
- G. Remove the retaining ring (10) from the shaft at the seal end. The seal (12) can now be removed from the shaft. Note how the seal and seat assembly (14) are arranged so they can be properly reassembled.
- H. For the E35, support the hub and press the shaft and housing assembly off of the hub.
- I. By removing the large internal retaining ring (11) from the bearing housing, the bearing (15) and shaft can be pressed out of the bearing housing. Support the bearing housing, and press on the shaft from the impeller end.
- J. Pumps designed without separate bearing housings may require shaft removal from opposite end depending on housing design.
- K. The seat assembly (13) is pressed into the bearing housing and can be removed by pushing a tool through the bearing end and against the rubber or backside of the seat.

Assembly:

- A. When replacing the carbon bushing (16) in the cover, care should be taken not to crack the bushing. A tool that pilots on the inside diameter and presses uniformly against the end of the bushing is recommended.
- B. When assembling the cam (7), put Permatex #1 on back side of cam and the screw (8) that retains the cam. Wipe off any Permatex that gets into the impeller cavity.
- C. Assemble a retaining ring (10) on the shaft into the second groove from the drive shaft end. Push the ball bearing (15) over the shaft (4). Press on the inner race of the bearing. Push the bearing up against the retaining ring. Assemble the second snap ring (10) over the shaft and up against the ball bearing, from the flat shaft end.
- D. Push the bearing and shaft assembly into the bearing housing (9) using care not to cock the bearing. A tool is recommended that will give you uniform pressure on the bearing outer race. Lock the bearing in place with the large internal retaining ring.
- E. For pumps without a bearing housing, assemble the seat (13) into the counter bore in the housing (3) with the ceramic facing the impeller. Push the shaft and bearing assembly into the housing. Lock the bearings in place with retaining ring (11). While supporting the shaft, press the hub onto the shaft.

R Series Technical Guide *(continued)*

Assembly/Disassembly Instructions

- F. From the opposite end (woodruff key end of the shaft), assemble the seat (13) over the shaft, rubber side first. Push it into the counter bore in the bearing housing. Do not damage (scratch) the white ceramic surface on the seat, or the seal and seat assembly might leak.
- G. Push the seal assembly (12) over the shaft and down against the seat. Do not damage the black carbon washer that rides against the ceramic.
- H. Assemble the third retaining ring (10) on the shaft. It will be necessary to compress the seal assembly to allow the retaining ring to enter the groove on the shaft.
- I. Press the woodruff key into the keyway in the shaft.
- J. Assemble the small gasket (17) over the pilot on the bearing housing and assemble the complete shaft, bearing, and seal assembly to the body. Use the two long screws (18) for fastening the bearing housing to the body. Torque the screws to 50 in.-lbs. for the R30G and R30G-1 or 84 in.-lbs. for the R10870G and R50G.
- K. Assemble the impeller (6) over the shaft (4). Line up the key in the shaft with the keyway in the impeller, and push the impeller into the body (3).
- L. Push the gasket (5) and cover (2) over the dowel pins, and attach the cover with the screws (1) and lockwashers. Torque the screws (1) to 50 in.-lbs. for the R30G and R30G-1 or 84 in.-lbs. for the R10870G, R50G, R102 and E35.
- M. After installation, inspect the pump seal, body, housing and cam areas for leaks.

Sherwood #		R30G	R30G-1	R10870G	R50G	R102	E35	
Port Size (NPT)		1/2"	1/2"	3/4"	3/4"	1"	1"	
Shaft Drive Description		Flat	Keved	Keved	Flat	Keved	Pulley Hub	
Item	QTY							
1	Screw	4/6	12686	18999	01482	01482	01483	01483
2	Cover Assy	1	10281	10281	10096	10096	10183	10183
3	Body Assy	1	10597	10597	10177	10177	18503	11246
4	Shaft	1	10289	11854	10852	10175	18502	11744
5	Gasket, Cover	1	10286	10286	10103	10103	10931	10931
6	Impeller	1	10077	10077	09959	09959	10615	10615
7	Cam	1	10285	10285	10072	10072	10929	10929
8	Cam Screw	1	10195	10195	09919	09919	10515	10515
9	Bearing/Housing Assy	1	10198	10198	10172	10172		
10	Retaining Ring (Ext)	3	04304	04304	04258	04258	04258	04258
11	Retaining Ring (Int)	1	04303	04303	04259	04259	04259	04259
12	Seal	1	10522	10522	18743	18743	18743	18743
13	Seat	1	11361	11361	10926	10926	10926	10926
14	Seal/Seat Assy	1	11367	11367	10927	10927	10927	10927
15	Ball Bearing	1	04306	04306	04257	04257	04257	04257
16	Bushing	1	02075	02075	06333	06333	06333	06333
17	Gasket, Housing	1	10197	10197	10171	10171		
18	Screws	2	05437	05437	04265	04265		
	Key	1	10093	10093	04432	04432	04432	04432
	Dowel Pin	2	01311	01311	01311	01311	01311	01311
	Plug	1/2	00336	00336	00336	00336	00336	00336
	Hub	1						97176
	Minor Repair Kit		10996	10996	10997	10997	10999	10999
	Major Repair Kit		24025	24025	12937	12937	11068	11068

P Series Technical Guide – 10615 Impeller

Assembly/Disassembly Instructions

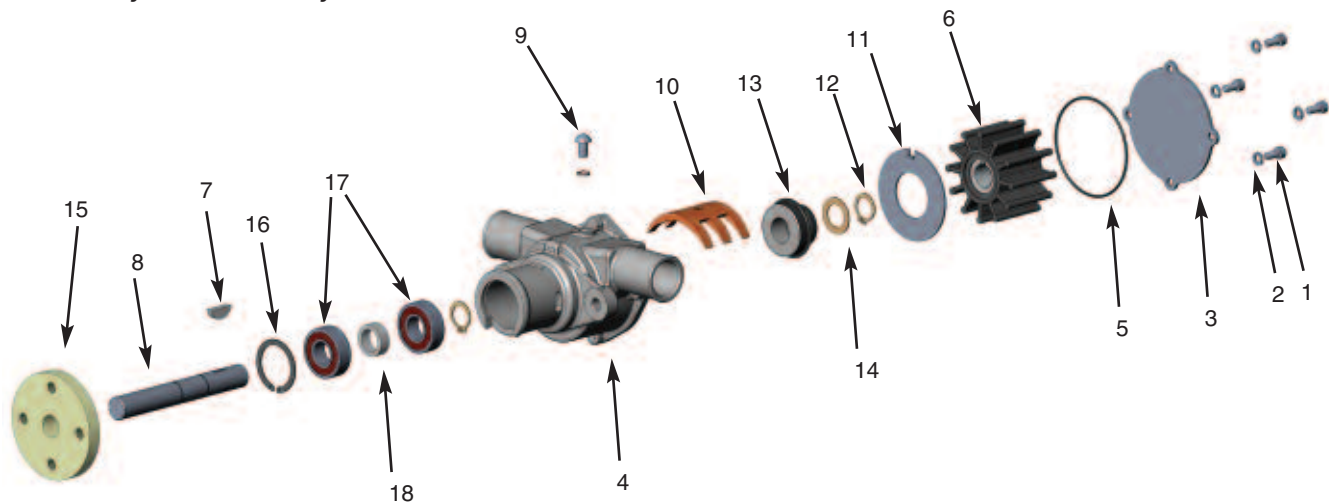

The following assembly/disassembly procedures apply to many P Series pumps. Deviations from pump to pump are primarily a result of different methods of drive and mounting.

Disassembly:

- A. Remove the screws (1) and lockwashers (2) that hold the cover (3) to the housing (4).
- B. Remove the o-ring or gasket (5) from the housing.
- C. Using two pliers or an impeller puller, remove the impeller (6) from the housing. Knock the key (7) out of the shaft (8).
- D. Remove the cam screw and washer (9) from the cam (10) and pull the cam out of the housing. The wear plate (11) can now be removed from the housing.
- E. Using an external snap ring pliers, remove the retaining ring (12) that holds the seal seat in place. Slide the seal seat (13) and washer (14) off the shaft.
- F. From the drive end of the pump (pulley end or hub end) locate a support directly between the pump housing and hub (15) as close to the shaft as possible. Make sure the housing is free and not supported, and then press the shaft out of the hub.
- G. Remove the large internal retaining ring (16) from the housing at the end of the bearing.
- H. Support the housing and press the shaft, bearings (17), spacer (18), slinger (19), and retaining ring (12) out through the pulley end or hub end of the housing.
- I. The seal assembly (13) is pressed into the body. It can be removed by pushing a tool through the bearing end and up against the metal or back side of the seal.
- J. Remove the retaining ring from the shaft and bearing assembly. Support the bearings on the inner race and push the shaft out of the bearings.

Assembly:

- A. Assemble a retaining ring (12) on the shaft into the second groove from the impeller end. Push the first ball bearing (17) from the pulley or drive end of the pump over the shaft (8) and against the retaining ring by pressing on the inner race of the bearing. Assemble the spacer (18), and then push the second ball bearing on the shaft and against the spacer in the same manner the first bearing was pressed on the shaft. Slide the slinger (19) against the retaining ring (it should be positioned between the bearings and mechanical seal).
- B. Press the mechanical seal (13) into the body from the impeller end. Make sure the seal is pressed in square and that the carbon face is not scratched during assembly. A tool should be used to assure proper assembly. The carbon face is positioned toward the impeller.
- C. Push the bearing and shaft assembly into the housing (4) using care not to cock the bearing. A tool is recommended that will give you uniform pressure on the bearing outer race. Lock the bearing in place with the large internal retaining ring (16).
- D. Assemble the ceramic seat assembly (13), washer (14) and retaining ring (12) over the shaft from the impeller end. Locate the white ceramic surface against the carbon face of the seal. Warning: Do not damage (scratch) the white ceramic surface of the seat or the carbon face of the seal – minor scratches can cause the seat assembly to leak. Lubricate the rubber part of the seat with a non-petroleum fluid for ease of assembly.

P Series Technical Guide – 10615 Impeller *(continued)*

Assembly/Disassembly Instructions

- E. Support the shaft at the impeller end without contacting the mechanical seal. Press the hub (15) onto the shaft flush to the ball bearings. Failure to support the shaft or placing pressure against the mechanical seal during this step will cause seal and/or bearing damage.
- F. Place the wear plate (11) in the housing. Put Permatex #1 on the backside of the cam (10) and the screw (9) that retains the cam. Wipe off any Permatex that gets into the impeller cavity. Assemble the cam by placing it into the housing and securing it with the cam screw and washer assembly. Press the woodruff key (9) into the shaft.
- G. Assemble the impeller (5) into the housing. **Note:** Do not use petroleum-based fluid to lubricate the impeller.
- H. Assemble the gasket or o-ring (5) and cover (3) on the housing. Replace the lockwashers (2) and screws (1) on the cover and torque the screws to 30-42 in-lbs on the P1016 and 50-60 in-lbs for all other pumps.
- I. After installation inspect the pump seal, housing, cam area, and cover for leaks.

	Sherwood #		P101	P1012	P1014	P1015	P1016
Item		QTY					
1	Cap Screw	4	21381	23966	23966	23966	24888
2	Lockwasher	4	00343	00343	00343	00343	24889
3	Cover Plate	1	19291	23946	21120	23912	24887
4	Housing	1	19294	19294	24107	24107	24882
5	O-Ring/Gasket	1	19251	19251	12231	12231	12231
6	Impeller	1	10615	10615	10615	10615	10615
7	Key	1	04432	04432	04432	04432	04432
8	Shaft	1	19293	19293	19293	19293	24885
9	Cam Screw Assy.	1	10515C	10515C	10515C	10515C	24884/19996
10	Cam	1	10944	10944	10944	10944	10929
11	Wear Plate	1	19295	19295	19295	19295	19295
12	Retaining Ring	2	04258	04258	04258	04258	04258
13	Water Seal/Seat Assy.	1	12859	12859	12859	12859	12859
14	Washer	1	04264	04264	04264	04264	04264
15	Hub	1	97176	97176	97176	97176	24883
16	Retaining Ring	1	04259	04259	04259	04259	04259
17	Bearing	2	12211	12211	12211	12211	12211
18	Spacer	1	05133	05133	05133	05133	24886
	Minor Repair Kit		19301	19301	23976	23976	23976
	Major Repair Kit		25029	25029	25030	25030	25028

17000 Series Technical Guide

Assembly/Disassembly Instructions

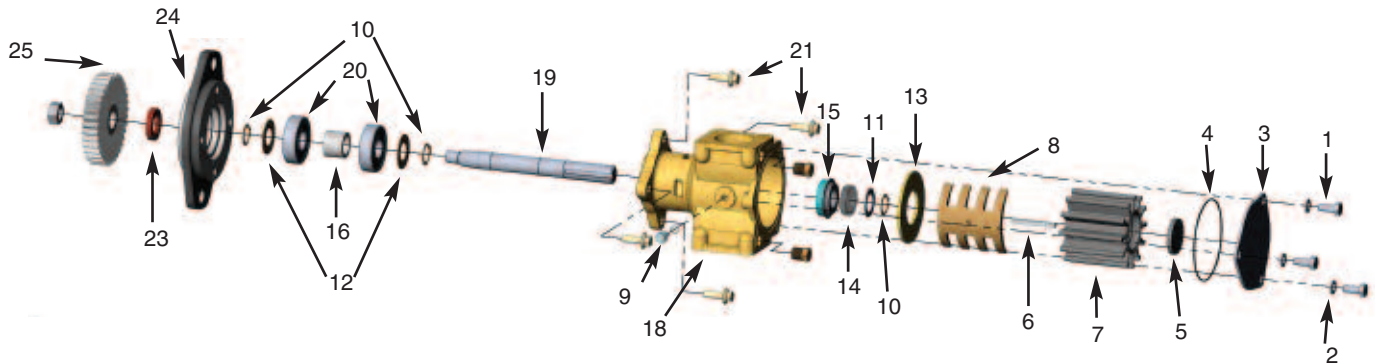

The following assembly/disassembly procedures apply to all 17000 Series pumps. Deviations from pump to pump are primarily a result of different methods of drive and mounting. Pump model numbers can be found stamped into the cover plate of the pump.

Disassembly:

- A. Remove the three bolts (1) and lock washers (2) from the pump cover (3). The cover and o-ring (4) are now free. The impeller end cap (5) can be pried off with a screwdriver. Normally, impellers (7) can be removed by using the 23631 impeller puller (or 3/4" – 16 bolt) for the 17000 threaded impeller, the 24412 impeller puller (or M16 x 1.5 bolt) for the 27000 threaded impeller, or by using two pair of pliers to grip two of the impeller's vanes on opposite sides of the impeller. A penetrating lubricant will help loosen a stuck impeller. Also, rotating the shaft by hand may help free the impeller. The 3/16" key (6) will also be removed at this time.
- B. Remove any pulleys or drive gears (25) from the drive shaft. For tapered shaft models (all models except P173, P1719, and P2701), it is necessary to remove the shaft nut and pull the gear or pulley with a puller. For models with pressed on gears (P173), two threaded holes are provided in the gear. An appropriate puller may be attached to these two holes to remove the gear from the shaft. The drive hub on the P2701 pump must be removed with a bearing puller.
- C. Most models will be equipped with a flange adapter (24). The flange adapter is held to the pump body by two socket head cap screws (21), either 3/8" or 10mm, depending on the model. The screws are removed by using a hex socket wrench. More current models are mounted with four 8mm flange hex head bolts. The adapter is then removed. If the lip seal (23) in the adapter requires replacing, it can be pressed out at this time.
- D. The cam (8) and cam screw (9) are removed. The internal wear plate (13) will drop out. The retaining ring (10), washer (11) and seal seat (14) are then removed.
- E. From the ball bearing end, the internal snap ring (17) must be removed on models P171 through P176, and P2701. Later models have extended bearing assemblies and are held together by means of the flanged adapter. The shaft/bearing assembly (19) is pressed out of the body from the impeller end of the housing removed from the engine end of the pump. The two external snap rings (10) are removed from the shaft (19) along with the bearing washers (12), permitting removal of bearings (20). The mechanical seal (15) may now be pressed from the bearing side of the housing (18).

Warning: If a shaft/bearing assembly exists for the particular model that is being repaired, do not try to build the shaft/bearing assembly from the individual parts, but instead purchase the entire assembly. Due to extremely tight tolerances, special assembly procedures for this assembly must be followed to prevent galling and subsequent leakage in the oil seal area of the pump.

Reassembly:

- A. Press mechanical seal (15) into housing (18) with the grey silicon carbide or black carbon seal face toward the impeller.
- B. On all older model pumps with mounting adapters, the lip seal (23) will have to be replaced prior to replacing the flange adapter (24). Care should be taken to insure proper alignment of the lip seal to the adapter and that the lip seal is uniformly pressed to prevent distortion. The metal backing ring of the lip seal goes toward the pump and away from the engine.
- C. Skip this step if the entire shaft/bearing assembly is available for the particular model that is being repaired. Install external snap ring (10) on shaft (19). Next, place washer (12), bearing (20), bearing spacer (16), second bearing (20) and washer (12) and secure with the second external snap ring (10). The bearings will have to be pressed on from the pulley/gear end.
Note: It is extremely important to properly align the bearings to the shaft prior to press, otherwise the possibility exists of galling the shaft in the area of the lip seal. This completes the bearing and shaft assembly.
- D. Press the bearing and shaft assembly into the housing (18). In applicable pump models, replace the internal snap ring (17). On newer model pumps, the bearings will be flush to the end of the housing or slightly protruding, and will be retained with the flange adapter (24). The adapter (24) may be reassembled to the pump housing (18) at this time with the two to four bolts (21). The use of Loctite #262 or equivalent is recommended on the adapter bolts. Torque the adapter bolts to 18 ft.-lbs.

18000 Series Technical Guide

Assembly/Disassembly Instructions

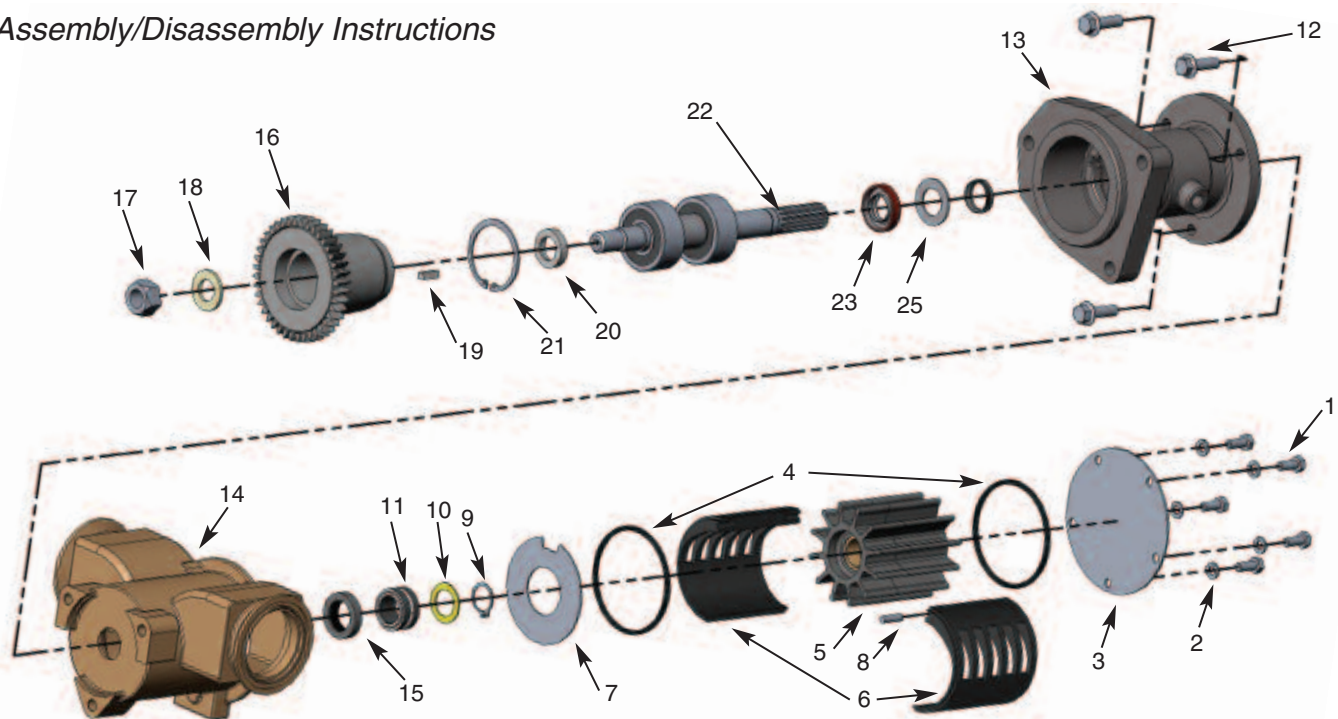

The following assembly/disassembly procedures apply to all 18000 Series pumps. Deviations from pump to pump are primarily a result of different methods of drive and mounting. Pump numbers can be found stamped into the cover plate of the pump.

Disassembly:

- A. Remove the bolts (1) and lockwashers (2) from the cover (3).
- B. Remove the cover, quad rings (4), impeller (5), cam liner halves (6), and wearplate (7). Note the direction of the impeller blades to ensure proper replacement of the impeller during the assembly procedure. **Caution:** the pin (8) might fall out from its place between the cam liner halves.
- C. Using external snap ring pliers, remove the retaining ring (9) from the shaft.
- D. Slide the washer (10) and mechanical seal (11) off of the shaft.
- E. Remove the bolts (12) holding the body (13) to the housing (14).
- F. Slide the housing off of the shaft and body assembly.
- G. Press the seal seat (15) out of the housing.
- H. When applicable remove the drive gear assembly: while supporting the drive gear (16), remove the nut (17), nut washer (18), and key (19) from the shaft. Slide the gear off of the shaft and remove the thrust washer (20) behind the gear.
- I. Using internal snap ring pliers, remove the retaining ring (21) from the body. Remove the bearing shield (24) from the body.
- J. Press the bearing and shaft assembly (22) out of the body.
- K. Remove the lip seal (23) and washer (25) from the body.
- L. Inspect the shaft for grooving of the lip seal area and heavy fretting of the spline portion that drives the impeller. Inspect the bearings for loss of grease, corrosion, and rough rotation. If the shaft or bearings exhibit such a wear, replace the entire shaft and bearing assembly (22).

Warning: Do not try to build the shaft and bearing assembly from the individual parts, but instead purchase the entire shaft and bearing assembly. Due to extremely tight tolerances, special assembly procedures for this assembly must be followed to prevent galling of the shaft in the lip seal area.

Assembly:

- A. Replace the washer (25) then press the lip seal (23) into the pump body (13) with the metal backing ring of the lip seal toward the housing (14) and away from the engine. Care should be taken to ensure proper alignment of the lip seal to the pump body and that the lip seal is uniformly pressed to prevent distortion.
- B. Press the shaft and bearing assembly (22) into the pump body.

18000 Series Technical Guide *(continued)*

- C. Slide the bearing shield (24) into the pump body and against the inner bearing.
- D. Using internal snap ring pliers, install the retaining ring (21) into the body.
- E. Press the mechanical seal seat (15) into the housing with the white ceramic seal face or gray silicon carbide face toward the impeller. Lubricate the outside of the seat boot with a water soluble lubricant or soapy water for easier assembly. Oil or grease must not be used as it will prevent the rubber cup assembly from properly gripping the housing. The seat should be inspected to ensure that the cup did not become partially dislodged during the assembly procedure.
- F. Slide the housing over the shaft and body assembly. Apply Loctite #262 or equivalent to the bolt threads. Fasten the three bolts (12) and torque them to 25 ft-lbs.
- G. When applicable, replace the drive gear assembly. Slide the thrust washer (20) onto the outer bearing. Place the key (19) in the shaft, then slide the gear (16) on the shaft. Apply Loctite #262 or equivalent to the shaft threads. Replace the washer (18), then tighten the nut (17) onto the shaft for the G1808, G18081-01, G18082-01 and G18082X. While supporting the drive gear, torque the nut to 270 ft-lbs. For all other models, refer to applicable engine manufacturer's torque requirements. 24007 contains 2 thrust washers. The G18082-01 utilizes the 23926 washer, which is .300" thick and 1.38" diameter of solid steel. The G1808 and G18081-01 use the 22779 washer, which is dimensionally the same, except it has a step in the internal diameter.
- H. Lubricate the inner rubber portion of the mechanical seal (11) with a water soluble lubricant or soapy water and slide the seal onto the shaft, with the carbon or silicon carbide portion of the mechanical seal toward the seal seat. Oil or grease must not be used as it will prevent the mechanical seal from properly gripping the shaft.
- I. Place the washer (10) onto the shaft and against the mechanical seal (see below to identify the proper washer) and then using external snap ring pliers, install the retaining ring (9) into the groove in the shaft to compress the mechanical seal.

Seal Washer Selection

When replacing the mechanical seal, it is necessary to ensure the proper seal washer is used to avoid damage to the pump. It is recommended that all pumps be upgraded with the silicon carbide mechanical seal 23837, except for pump number G1810, G1810-01, G1810x, G1811-01, G1815-01, G1816-01, which can only be fitted with the 23512 seal. The G1814-01 and G1814x use the 24511 silicon carbide mechanical seal. Use the following to determine which washer to use:

- When using the silicon carbide mechanical seal 23837 for replacement, determine the proper spacer to use from the chart below. Silicon carbide is characterized by the charcoal gray-colored seal and seat faces, as opposed to carbon on ceramic, which would be black on white.
- Exceptions to the chart:
 - If the pump is to be fitted with the new shaft and bearing assembly listed on the chart on page 40 (24000, 24001, 24002, and 24003), use the 19866 washer. These shaft and bearing assemblies can only be used with the 23837 silicon carbide mechanical seals.
 - Replacement of the seal with the carbon on ceramic mechanical seal 19878 can only be performed on older units with the original shaft and bearing assemblies still in place. Use the 19866 spacer in such cases. Use of the 19878 seal with the current production units (G18061-01, G18071-01, and G18081-01) or with older units fitted with the new shaft and bearing assemblies will cause damage to the pump.

Pump Number	23837 Seal Spacer Number *
G1801	23840
G1804	23840
G1805	23840
G1806	23840
G18061-01	19866
G1807	23840
G18071-01	19866
G1808	23840
G18081-01	19866
G18082-01	19866
All Others**	N/A

Note: If the pump is fitted with a silicon carbide seal, it must be replaced with the 23837 silicon carbide seal to prevent damage.

**Note: The 19866 spacer is .060" thick and the 23840 is .260" thick.*

*** G1810, G1810-01, G1811-01, G1815-01, G1816-01 use the 23512 seal only. The G1814-01 and G1814X use the 24511 silicon carbide mechanical seal.*

- J. Install the wearplate (7) with the hole in the plate lined up with the slot in the housing. Install the quad ring (4) into the housing and on top of the wearplate.
- K. Create the cam assembly by connecting the cam halves (6) together and installing the pin (8) into the cam liner. A dab of grease can be used to hold the pin in place during installation. Place the cam assembly into the housing, ensuring that the pin aligns with the slot in the housing.
- L. Insert the impeller (5) in the housing using a twisting motion. Ensure that the impeller blades are bent in the same direction as upon removal (dependent on the pump model). For ease of installation, apply a silicon lubricant to the impeller. **Caution:** Do not use a petroleum-based lubricant (petroleum product will cause damage to the impeller).

18000 Series Technical Guide *(continued)*



Vanes flipped to the left (viewed from cover).

Models:
G1808, G18081-01,
G18082, G18082X,
G1810, G1810-01,
G1814-01, G1814X,
G1811-01 and G1816-01



Vanes flipped to the right (viewed from cover).

Models:
G1801, G1804, G1805,
G1806, G18061-01, G1807,
G18071-01 and G1815-01

- M. Insert the remaining quad ring (4) into the groove, install the cover (3) on the housing, and then fasten the lockwashers (2) and bolts (1) to 8 ft.-lbs. torque.
- N. After installation, inspect the pump seal, lip seal, body and housing areas for leaks.

	Sherwood #		G1801	G1804	G1805	G1806	G18061-01	G1807	G18071-01	G1808	G18081-01
Item		QTY									
1	Cap Screw	5	19626	19626	19626	19626	19626	19626	19626	19626	19626
2	Lockwasher	5	15944	15944	15944	15944	15944	15944	15944	15944	15944
3	Cover Plate	1	19837	19837	19837	19837	19837	19837	19837	19837	19837
4	Quad Rings	2	19879	21561	21561	21561	21561	21561	21561	21561	21561
5	Impeller	1	18000	18000	18000	18000	18000	18000	18000	18000	18000
6	Cam Liner Halves	2	19829	21533	21106	21533	21533	21106	21106	21533	21533
7	Wear Plate	1	19836	19836	19836	19836	19836	19836	19836	19836	19836
8	Pin	1		21566	21566	21566	21566	21566	21566	21566	21566
9	Retaining Ring	2	19762	19762	19762	19762	19762	19762	19762	19762	19762
10	Washer	1	19866	19866	19866	19866	19866	19866	19866	19866	19866
11/15	Mechanical Seal Assy	1	19878	19878	19878	19878	23837	19878	23837	19878	23837
12	Bolt	3	21172	21172	21172	21172	21172	21172	21172	21172	21172
13	Body	1	19827	21476	21920	21986	21986	21827	21827	22412	22412
14	Housing	1	19828	21565	21829	21829	21829	21829	21829	22762	22762
16	Gear	1								22789	22789
17	Nut	1								22790	22790
18	Washer	1								22788	22788
19	Key	1								22791	22791
20	Gear Spacer	1								22779	22779
21	Retaining Ring	1	19867	19867	19867	19867	19867	19867	19867	19867	19867
22	Bearing and Shaft Assy	1	24000	24001	24000	24001	24001	24001	24001	24002	24002
23	Lip Seal	1	19869	19869	19869	19869	19869	19869	19869	23045	23045
24	Bearing Shield	1									
25	Washer	1	19835	19835	19835	19835	19835	19835	19835	19835	19835
	Minor Repair Kit			24004	24023	24004	24004	24023	24023	24004	24004
	Major Repair Kit			24006	24024	24006	24006	24024	24024	24007	24007

* When using these Shaft and Bearing Assemblies, replace the seal with the silicon carbide mechanical seal 23837 only. Use of the 19878 mechanical seal with these Shaft and Bearing Assemblies may cause pump damage. See "Seal Washer Selection" on page 40.

	Sherwood #		G18082-01	G18082X	G1810	G1810-01	G1810X	G1811-01	G1814-01	G1814X	G1815-01	G1816-01
Item		QTY										
1	Cap Screw	5	19626	19626	19626	19626	19626	19626	19626	19626	19626	19626
2	Lockwasher	5	15944	15944	15944	15944	15944	15944	15944	15944	15944	15944
3	Cover Plate	1	19837	19837	19837	19837	19837	19837	19837	19837	19837	19837
4	Quad Rings	2	21561	21561	21561	21561	21561	21561	21561	21561	21561	21561
5	Impeller	1	18000	18000	18000	18000	18000	18000S	18000S	18000	18000S	18000S
6	Cam Liner Halves	2	21533	21533	21106	21106	21106	21106	21106	21106	21533	21533
7	Wear Plate	1	19836	19836	19836	19836	19836	19836	19836	19836	19836	19836
8	Pin	1	21566	21566	21566	21566	21566	21566	21566	21566	21566	21566
9	Retaining Ring	2	19762	19762	19762	19762	19762	19762	19762	19762	19762	19762
10	Washer	1	19866	19866	19866	19866	19866	19866	19866	19866	19866	19866
11/15	Mechanical Seal Assy	1	23837	23837	23512	23512	23512	23512	24511	24511	23512	23512
12	Bolt	3	21172	21172	23296	23296	23296	23296	23296	23296	23296	23296
13	Body	1	23916	23916	23396	23396	23396	24174	23396	23396	24174	24174
14	Housing	1	22762	22762	23523	23523	23523	23523	23523	23523	23523	23523
16	Gear	1	22789	22789								
17	Nut	1	22790	22790								
18	Washer	1	22788	22788								
19	Key	1	22791	22791								
20	Gear Spacer	1	23926	23926								
21	Retaining Ring	1	19867	19867	19867	19867	19867	19867	19867	19867	19867	19867
22	Bearing and Shaft Assy	1	24463	24463	24003	24003	24003	24003	24003	24003	24003	24003
23	Lip Seal	1	23045	23045	23045	23045	23045	23045	23045	23045	19869	23045
24	Bearing Shield	1	23425	23425	23425	23425	23425	23425	23425	23425	23425	23425
25	Washer	1										
	Minor Repair Kit		24004	24004	24005	24005	24005	24005			24753	24760
	Major Repair Kit		24007	24007	24008	24008	24008	24008	24655	24655	24754	24761

22000 Series Technical Guide

Assembly/Disassembly Instructions

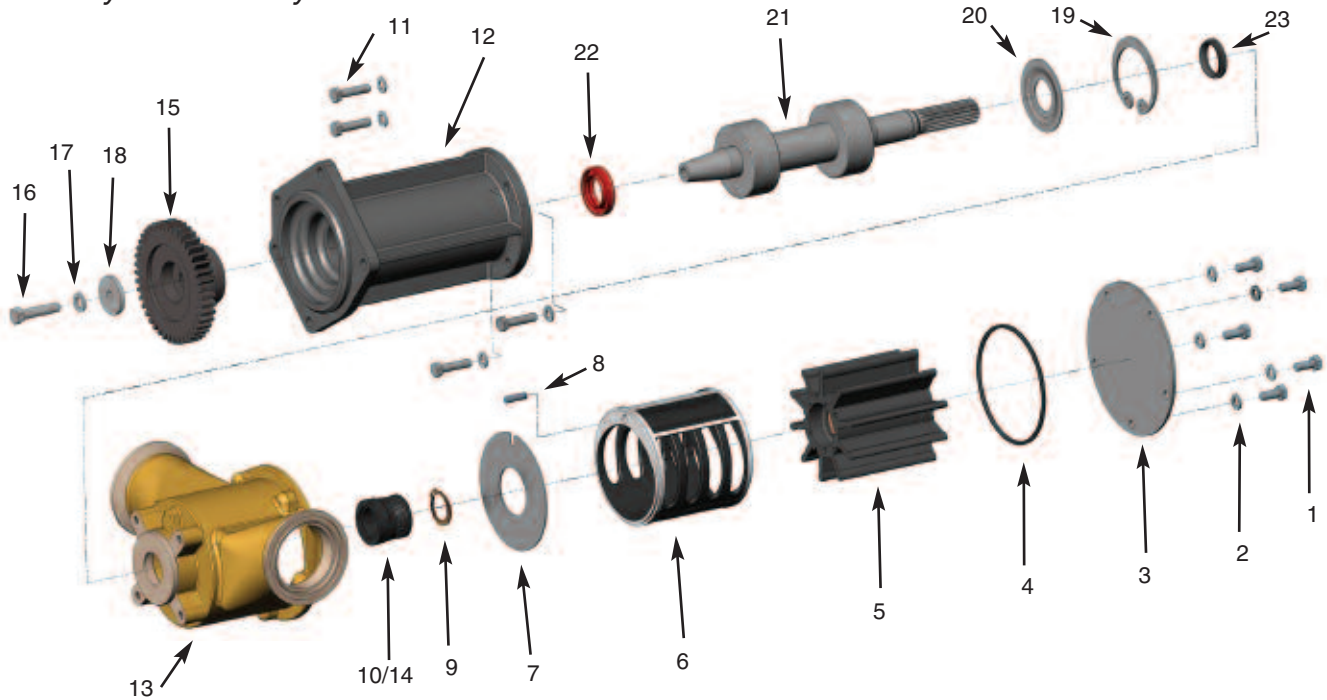

The following assembly/disassembly procedures apply to all G22000 Series pumps. Pump numbers can be found stamped into the cover plate of the pump.

Disassembly

- A. Remove the bolts (1) and lockwashers (2) from the cover (3).
- B. Remove the cover and quad ring (4). Note the direction of the impeller blades to ensure proper replacement of the impeller during the assembly procedure. The impeller (5) can be removed with impeller puller 23631 or a 3/4"- 16 bolt (by screwing the bolt into the threaded impeller, the impeller is jacked out of the pump). **Caution:** The pin (8) might fall out from its place when removing the cam.
- C. The cam (6), cam anti-rotation pin, and wearplate (7) can be removed.
- D. Using external snap ring pliers, remove the retaining ring (9) from the shaft.
- E. Slide the mechanical seal (10) off of the shaft.
- F. Remove the bolts (11) and lockwashers holding the body (12) to the housing (13).
- G. Slide the housing off of the shaft and body assembly.
- H. Press the seal seat (14) out of the housing.
- I. When applicable, remove the drive gear assembly: while supporting the drive gear (15), remove the bolt (16), lockwasher (17) and thrust washer (18) from the shaft. Pull the gear off of the tapered shaft using a bearing or wheel puller.
- J. Using internal snap ring pliers, remove the retaining ring (19) from the body. For the G22012-01 and G22012X, remove the bearing shield (20) from the body.
- K. Press the bearing and shaft assembly (21) out of the body.
- L. Remove the lip seal (22) from the body.
- M. Inspect the shaft for grooving of the lip seal area and heavy fretting of the spline portion that drives the impeller. Inspect the bearings for loss of grease, corrosion and rough rotation. If the shaft or bearings exhibit such a wear, replace the entire shaft and bearing assembly (21).

Warning: Do not try to build the shaft and bearing assembly from the individual parts, but instead purchase the entire shaft and bearing assembly. Due to tight tolerances, special assembly procedures for this assembly must be followed to prevent galling of the shaft in the lip seal area.

22000 Series Technical Guide *(continued)*

Assembly

- A. The lip seal (22) should be pressed in the body (12) with the metal backing ring of the lip seal toward the housing (13) and away from the engine.

Caution: For the G22012-01 and G22012X, when pressing the lip seal in the body from the impeller end, the lip seal should be pressed 0.065" plus/minus 0.010" past the furthest bearing location. See detailed illustration. This position is critical to the performance of the oil seal since it needs to be placed slightly further than the bearing, but not as far as the beginning of the taper. Failure to place the seal at this location will cause the lip seal to contact the tapered portion of the shaft which will cause premature lip seal wear. Care should also be taken to ensure proper alignment of the lip seal to the pump body and that the lip seal is uniformly pressed to prevent distortion.

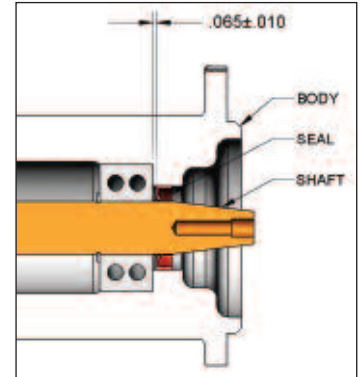

Close-up Drawing of Lip Seal Area

- B. Press the shaft and bearing assembly (21) into the pump body. For the G22012-01 and G22012X, ensure that the lip seal will not wear on the tapered portion of the shaft (see **Caution** above). Replace the slinger (23) on the shaft between the mechanical seal position and the bearings.
- C. For the G22012-01 and G22012X, slide the bearing shield (20) into the pump body and against the inner bearing.
- D. Using internal snap ring pliers, install the retaining ring (19) into the body.
- E. Press the mechanical seal seat (14) into the housing (13) with the gray silicon carbide face toward the impeller. Lubricate the outside of the seat boot with a water soluble lubricant or soapy water for easier assembly. Oil or grease must not be used as it will prevent the rubber cup assembly from properly gripping the housing. The seat should be inspected to ensure that the cup did not become partially dislodged during the assembly procedure.
- F. Slide the housing over the shaft and body assembly. Fasten the four bolts (11) and lockwashers, and torque them to 12-16 ft-lbs.
- G. Replace the drive gear assembly. Slide the gear (15) on the shaft. Place the thrust washer (18) on the gear and against the shaft. Place the lockwasher (17) on the bolt (16), and then apply Loctite #262 or equivalent to the bolt. Fasten the bolt to the shaft and torque it to 36 ft-lbs.
- H. Lubricate the internal rubber portion of the mechanical seal (10) with a water soluble lubricant or soapy water and slide the seal onto the shaft with the silicon carbide portion of the mechanical seal toward the seal seat. Oil or grease must not be used as it will prevent the mechanical seal from properly gripping the shaft.
- I. Using external snap ring pliers, replace the retaining ring (9) on the shaft.
- J. Install the pin (8) into the housing.
- K. Install the wear plate (7) with the hole in the plate aligned with the pin in the housing.
- L. Place the cam (6) in the housing. Align the hole in the cam with the pin in the housing and ensure the anti-rotation pin is in place after the cam is fully installed.
- M. Insert the impeller (5) in the housing using a twisting motion. Ensure that the impeller blades are bent in the same direction as upon removal (counterclockwise when viewed from the cover). For ease of installation, apply a silicon lubricant to the impeller. **Caution:** Do not use a petroleum-based lubricant (petroleum product will cause damage to the impeller).
- N. Insert the quad ring (4) into the groove, install the cover (3) on the housing, and then fasten the lockwashers (2) and bolts (1). Torque the cover bolts to 5-8 ft-lbs.
- O. After installation, inspect the seal, body, housing and cover for leaks.

	Sherwood #		G2201	G22011-01	G22012-01	G22012X
Item	QTY					
1	Cap Screw	5	19626	19626	19626	19626
2	Lockwasher	9	15944	15944	15944	15944
3	Cover Plate	1	23113	23113	23113	23113
4	Quad Ring	1	23111	23111	23111	23111
5	Impeller	1	22000	22000	22000	22000
6	Cam	1	24160	24160	24160	24160
7	Wear Plate	1	23112	23112	23112	23112
8	Pin	1	21566	21566	21566	21566
9	Retaining Ring	1	23115	23115	23115	23115
10/14	Mechanical Seal Assy.	1	23087	23906	23906	23906
11	Bolt	4	23211	23211	23211	23211
12	Body	1	23056	23056	23919	23919
13	Housing	1	23057	24229	24159	24159
15	Gear	1	23181	23181	23181	23181
16	Bolt	1	23194	23194	23194	23194
17	Lockwasher	1	23196	23196	23196	23196
18	Thrust Washer	1	23195	23195	23195	23195
19	Retaining Ring	1	23091	23091	23091	23091
20	Bearing Shield	1			23922	23922
21	Bearing and Shaft Assy.	1	24464	24464	24465	24465
22	Lip Seal	1	23088	23088	23088	23088
23	Slinger	1			23924	23924
	Minor Repair Kit		24870	24870	24870	24870
	Major Repair Kit		24872	24872	24872	24872

26000 Series Technical Guide

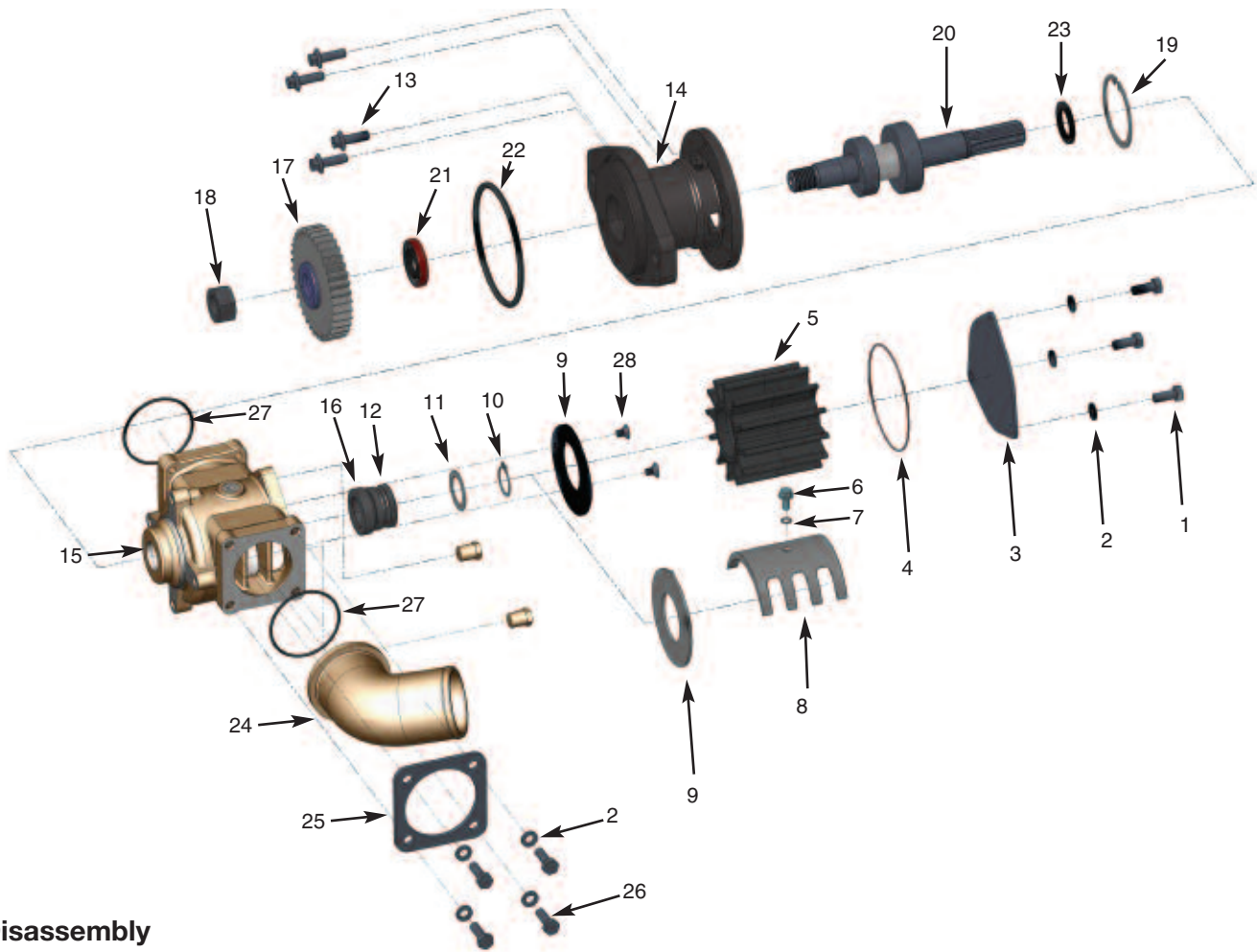

Disassembly

Note: It may not be necessary to perform the entire disassembly procedure for the intermediate and minor kits.

- A. Remove the bolts (1) and lockwashers (2) from the cover (3).
- B. Remove the cover, o-ring (4), and impeller (5), using puller number 23631 or 3/4" x 16 UNF bolt. Note the direction of the impeller blades to ensure proper replacement of the impeller during the assembly procedure.
- C. When applicable, remove the cam screw (6) and cam screw o-ring (7) from the cam. The cam (8) and wearplate (9) can now be taken out of the housing.
- D. For the G2603, G2604 and G2605 pump models with integrated cam designs, remove the two wearplate flat head screws (28) holding the wearplate in place.
- E. Using external snap ring pliers, remove the retaining ring (10) from the shaft.
- F. Slide the washer (11) and mechanical water seal (12) off of the shaft.
- G. Remove the bolts (13) holding the body (14) to the housing (15).
- H. Slide the housing off of the shaft and body assembly.
- I. Press the seal seat (16) out of the housing.
- J. Remove the drive gear assembly. While supporting the drive gear (17), remove the nut (18) from the shaft.
- K. Using internal snap ring pliers, remove the retaining ring (19) from the body.
- L. Press the bearing and shaft assembly (20) out of the body.
- M. Remove the lip seal (21) and o-ring (22) from the body.
- N. Inspect the shaft for grooving of the lip seal area and heavy fretting of the spline portion that drives the impeller. Inspect the bearings for loss of grease, corrosion and rough rotation. If the shaft or bearings exhibit such a wear, replace the entire shaft and bearing assembly (20).

26000 Series Technical Guide *(continued)*

Assembly

Warning: Do not try to build the shaft and bearing assembly from the individual parts, but instead purchase the kit with entire shaft and bearing assembly. Special assembly procedures for this assembly must be followed to prevent galling of the shaft in the lip seal and mechanical seal area, which could cause premature seal leaks.

- A. Replace the o-ring (22) in the pump body (14), then press the lip seal (21) in place with the metal backing ring of the lip seal toward the housing (15) and away from the engine, until it is flush with the body surface. Care should be taken to ensure proper alignment of the lip seal to the pump body and that the lip seal is uniformly pressed to prevent distortion.
- B. Press the shaft and bearing assembly (20) into the pump body. Preferably, use a sleeve or piece of tubing, slightly bigger than the shaft (25mm) or about an 1" opening, to push against the inner race of the ball bearing.
- C. Using internal snap ring pliers, install the retaining ring (19) into the body. Then slide the slinger (23) onto the impeller end of the shaft to about 1/8" away from the bearings.
- D. Press the mechanical seal seat (15) into the housing with the gray silicon carbide face toward the impeller. Lubricate the out side of the seat boot with a water-soluble lubricant or soapy water for easier assembly. Oil or grease must not be used, as it will prevent the rubber cup assembly from properly gripping the housing. The seat should be inspected to ensure that the cup did not become partially dislodged during the assembly procedure.
- E. Slide the housing (15) over the shaft and body assembly. Use Loctite® Primer and Loctite® 262 or equivalent on the body to housing bolts. Fasten the three bolts (13) and torque them to 18 ft-lbs.
- F. When applicable, replace the drive gear assembly. Use Loctite® Primer and Loctite® 262 or equivalent on the gear nut. Slide the gear (17) on the shaft, and then tighten the nut (18) onto the shaft. While supporting the drive gear, torque the nut to 130-140 ft-lbs.
- G. Lubricate the inner rubber portion of the mechanical water seal (12) with a water soluble lubricant or soapy water and slide the seal onto the shaft, with the silicon carbide portion of the mechanical water seal (12) toward the seal seat (16).
Note: The two mating surfaces must be the gray silicon carbide portion of the seal to the gray silicon carbide portion of the seal seat. Oil or grease must not be used to prevent the mechanical seal from properly gripping the shaft.
- H. Place the washer (11) onto the shaft and then using external snap ring pliers, install the retaining ring (10) into the groove in the shaft to compress the mechanical seal.
- I. Install the wearplate (9) with the anti-rotation tab into the recess in the housing.
- J. For the G2603, G2604 and G2605 pump models with integrated cam designs, apply Loctite® 242 to the wearplate flat head screw threads (28), replace the two screws to secure the wear plate, and torque them to 50 in-lbs.
- K. When applicable, replace the cam (8) in the housing. Place the cam screw o-ring (7) onto the cam screw (6) and then fasten the cam screw in place.
- L. Insert the impeller (5) in the housing using a twisting motion. Ensure that the impeller blades are bent in the same direction as upon removal. For ease of installation, apply a silicon lubricant to the impeller. **Caution:** Do not use a petroleum-based lubricant (petroleum product will cause damage to the impeller).
- M. Insert the O-ring (4) into the groove, install the cover (3) on the housing, and then fasten the lockwashers (2) and bolts (1) to 8 ft-lbs. torque.
- N. If necessary to replace the port elbow, slide the port (24) through the bracket (25). Replace the o-ring (27). Fasten the lockwashers and bolts (26) through the port bracket to the housing and torque to 12 ft-lbs.
- O. After installation, inspect the seals, housing, body and cam areas for leaks.

26000 Series Technical Guide *(continued)*

Item	Sherwood #	QTY	G2601-01	G2601-02	G2601-03	G2601X	G2602-01
1	Cap Screw	3	19626	19626	19626	19626	19626
2	Lockwasher	3/7	21573	21573	21573	21573	21573
3	Cover Plate	1	24074	24074	24074	24074	24074
4	O-Ring	1	19879	19879	19879	19879	19879
5	Impeller	1	26000	26000	26000	26000	26000
6	Cam Screw	1	19714	19714	19714	19714	19714
7	O-Ring	1	19712	19712	19712	19712	19712
8	Cam	1	24075	24075	24075	24075	24075
9	Wear Plate	1	24073	24073	24073	24073	24073
10	Retaining Ring	1	19762	19762	19762	19762	19762
11	Washer	1	19866	19866	19866	19866	19866
12/16	Mechanical Seal Assy	1	23837	23837	23837	23837	23837
13	Bolt	4	19708	19708	19708	19708	19708
14	Body	1	24102	24102	24102	24102	24102
15	Housing	1	24072	24072	24072	24072	24072
17	Gear	1	24083	24083		24083	24083
18	Nut	1	24084	24084	24084	24084	24084
19	Retaining Ring	1	19867	19867	19867	19867	19867
20	Shaft & Bearing Assy	1	24223	24223	24223	24223	24223
21	Lip Seal	1	19869	19869	19869	19869	19869
22	O-Ring	1	1720-0212	1720-0212	1720-0212	1720-0212	1720-0212
23	Slinger	1	24079	24079	24079	24079	24079
24	Port Elbow	1	24076				24132
25	Bracket	1	24081				24081
26	Cap Screw	4	21484				21484
27	O-Ring	2	24052				24052
28	Screw	2					
	Minor Repair Kit		24227	24227	24227	24227	24227
	Major Repair Kit		24840	24840	24840	24840	24228

Item	Sherwood #	QTY	G2603-01	G2603-02	G2603-03	G2603X	G2604-01	G2605-01
1	Cap Screw	3	19626	19626	19626	19626	19626	19626
2	Lockwasher	3/7	21573	21573	21573	21573	21573	21573
3	Cover Plate	1	24074	24074	24074	24074	24074	24074
4	O-Ring	1	19879	19879	19879	19879	19879	19879
5	Impeller	1	26000	26000	26000	26000	26000	26000
6	Cam Screw	1	19714	19714	19714	19714	19714	19714
7	O-Ring	1	19712	19712	19712	19712	19712	19712
8	Cam	1						
9	Wear Plate	1	24790	24790	24790	24790	24790	24790
10	Retaining Ring	1	19762	19762	19762	19762	19762	19762
11	Washer	1	19866	19866	19866	19866	19866	19866
12/16	Mechanical Seal Assy	1	23837	23837	23837	23837	23837	23837
13	Bolt	4	19708	19708	19708	19708	19708	19708
14	Body	1	24102	24102	24102	24102	24102	24102
15	Housing	1	24789	24789	24789	24789	24789	24789
17	Gear	1	24083	24083			24083	24083
18	Nut	1	24084	24084		24084	24084	24084
19	Retaining Ring	1	19867	19867	19867	19867	19867	19867
20	Shaft & Bearing Assy	1	24223	24223	24223	24223	24223	24223
21	Lip Seal	1	19869	19869	19869	19869	19869	19869
22	O-Ring	1	1720-0212	1720-0212	1720-0212	1720-0212	1720-0212	1720-0212
23	Slinger	1	24079	24079	24079	24079	24079	24079
24	Port Elbow	1	24076				24132	24630
25	Bracket	1	24081		24081		24081	24081
26	Cap Screw	4	21484		21484		21484	21484
27	O-Ring	2	24052	24052	24052		24052	24052
28	Screw	2	24840	24840	24840	24840	24840	24840
	Minor Repair Kit		24841	24841	24841	24841	24841	24841
	Major Repair Kit		24842	24842	24842	24842	24842	24842

Preventative Maintenance and Inspection

Maintenance Schedule	Pleasure Boating (Low Hours)		Commercial/Fishing Use (High Hours)	
	Light Duty	Severe Duty (High RPM, Silt or Sand)	Heavy Duty	Severe Duty (High RPM, Silt or Sand)
Impeller Kit	Every year	6 - 12 months	6 - 12 months	3 - 6 months
Minor Kit	2 years	Every year	Every year	6 months
Major Kit	4 years	2 years	2 years	Every year

* See pages 16-29 for Repair Kit Part Numbers.

The #1 reason for premature engine wear is overheating.

To maintain engine performance, insist upon genuine Sherwood impellers and service kits.

Recommended inspection to be performed at any service interval:

- Impeller Inspect for cracks or tears. Also, inspect for excessive abrasion of vane ends. Replace annually, or if any of the conditions exist, as in the picture.
- Wear Plate Inspect for wear, flatness, and pin for fatigue. Replace at major pump rebuild or if wear is evident to maintain pump flow and suction performance.
- Cam Replace at minor or major pump rebuild or if pitting/wear is evident.
- Cover Replace at major pump rebuild or if wear exists to maintain pump flow and suction performance.
- Mechanical Seal Replace at minor and major pump rebuild or if leaking.
- Lip Seal Replace at major pump rebuild or if leaking.
- Shaft Inspect for wear in area of lip seal and rubber impeller. Grooving of lip seal area or heavy fretting of the impeller end shaft will require shaft replacement.
- Bearing Inspect for loss of grease, corrosion or rough rotation. Replace at major pump rebuild.

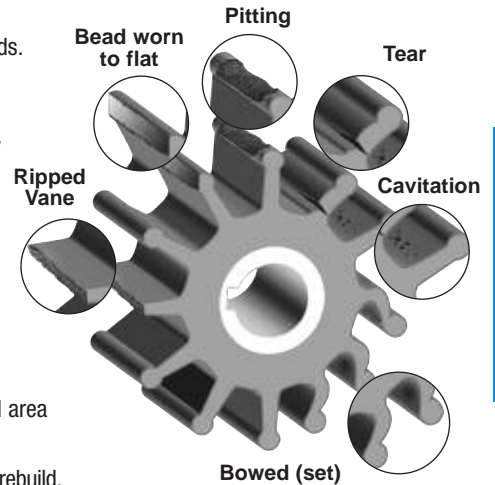

Sherwood Tech Tips

To maintain best engine performance and to prolong engine life - replace your impeller annually.

Three tips to help you install your new impeller:

- Use a non-petroleum based lubricant (silicon or soapy water) to help slide the impeller into the housing.
- Install the impeller with a twisting motion onto the shaft. Never force an impeller onto the shaft. The impeller must be able to move freely on the shaft to properly prime and function.
- Use a small amount of non-petroleum based lubricant to help hold the o-ring when replacing the cover.

Proper storage of the impellers during a prolonged lay-up can help maintain the life of the impeller. Remove the impeller from the housing and store in a cool, dark place. This will avoid the following:

- Copper bonding of the impeller to the housing
- Ultraviolet deterioration
- Vanes "setting" into position as stored in the housing

How Does a Rubber Impeller Pump Work?

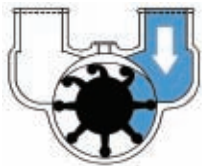

1 A self-priming vacuum is created as the flexible impeller vanes straighten upon leaving the cam, drawing liquid into the pump.

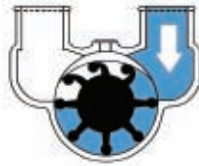

2 The rotating impeller carries liquid from the inlet to the outlet port. As a consequence of their design, flexible impeller pumps can pass fairly large solids.



3 When the flexible impeller vanes regain contact with the cam, they bend and the liquid is discharged from the pump in a uniform flow. Liquids can be pumped in the opposite direction by reversing the rotation of the pump.

Which is my inlet and which is my outlet port?

If you locate the cam and know which way the pump is rotating, you can figure out which port is which.

Cam (Held in place with single screw in-between the ports)

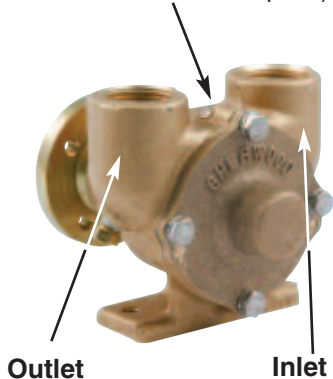

Integrated Cam with no screw (The smallest span between the ports is where the cam is located.)

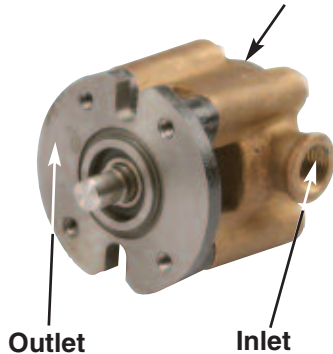

Cam (Held in place with single screw in-between the ports)

