



SHURFLO AQUA KING™ II SUPREME 5.0

MARINE FRESH WATER PUMP – PRODUCT TECHNICAL DATA SHEET

OEM: 4158-163-A75
 AFTERMARKET: 4158-163-E75



APPLICATION:

Multi-fixture Marine fresh water pump installation.
 This pump may be used for general fresh water transfer

PUMP DESIGN:

Type: 4 Chamber Diaphragm pump
 Check Valve: (1-way operation) Prevents Reverse Flow
 Ports: ½"-14 NPSM-Male
 Liquid: 130°F [54°C] Max
 Dry-Prime: 6 feet [1.82 M]
 Run Dry: Yes
 Inlet Pressure: 30 PSI Max. [2.06 Bar]

Aftermarket model includes:

- 50 Mesh strainer: swivel straight adapter ½-14 NPT (hex-wing nut) X ½-14 NPS (male)
- Fittings: swivel straight adapter ½-14 NPT (hex-wing nut) x ½ barb (Qty. 2)

ELECTRICAL:

Motor: 24V DC Permanent Magnet, Intermittent Duty.
 Protection: Thermal Overload, Automatic Restart
 Leads: 14 AWG, 14 ¾" [37 cm] Red +, 15" [38 cm] Black
 Fuse: 7.5 Amp Recommended
 Control: Shut-Off 55 PSI [3.8 Bar] ± 2 PSI [0.13 Bar]
 Re-start 40 PSI [2.8 Bar] ± 2 PSI [0.13 Bar]
 Maximum By-Pass 65 PSI [4.5 Bar] ± 2 PSI [0.13 Bar]

MATERIALS OF CONSTRUCTION:

Housings: Polypro
 Valves/Seals: EPDM
 Diaphragm: Santoprene
 Hardware: Stainless Steel

AGENCY APPROVALS:

Ignition Protection 8846, CE, IMCI Certified

SHIPPING INFORMATION:

Approx. Net Weight: 7.9 Pounds [3.5 Kg] ea.
 Carton Qty.: 6
 Approx. Carton Weight: 50 Lbs. [22.6 Kg]
 Approx. Carton Size: 24"L X 18"W X 6"H [61cm x 46cm x 15cm]
 Retail (individual) box: 12"L X 6"W X 6"H [30cm x 15cm x 15cm]

REPAIR KITS

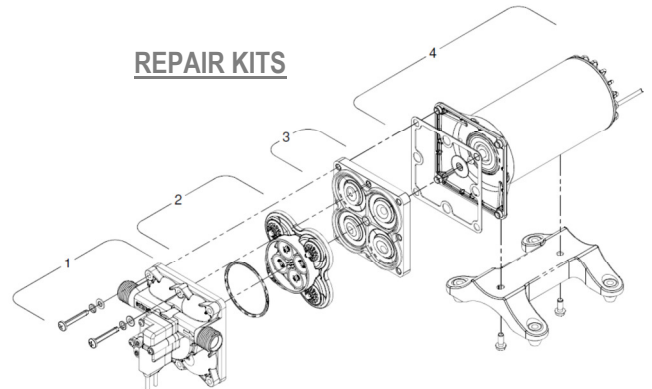

Number	Description	Part Number
*1	Upper Assembly	94-801-10
2	Valve Assembly	94-800-01
3	Drive Assembly	94-801-12
4	Motor/Gasket	94-71-001-04
*1,2,3,	Pump Head	94-801-13
Not Shown	Check Valve	94-800-03

*With preset switch and by-pass adjustment