



SHURFLO PROBLASTER™ II DELUXE 4.0

MARINE WASHDOWN PUMP – PRODUCT TECHNICAL DATA SHEET

OEM: 4248-163-A09
 AFTERMARKET: 4248-163-E09



APPLICATION:

Marine fresh or salt water wash-down installation.
 This pump may be used for general water transfer.

PUMP DESIGN:

Type: 4 Chamber Diaphragm pump
 Ports: ½”-14 NPSM-Male
 Liquid: 130°F [54°C] Max
 Dry-Prime: 6 feet [1.82 M]
 Run Dry: Yes
 Inlet Pressure: 30 PSI Max. [2.06 Bar]

ELECTRICAL:

Motor: 24V DC Permanent Magnet, Intermittent Duty.
 Protection: Thermal Overload, Automatic Restart
 Leads: 14 AWG, 14 ¾” [37 cm] Red +, 15” [38 cm] Black
 Fuse: 7.5 Amp Recommended
 Control: Shut-Off 60 PSI [4.1 Bar] ± 2 PSI [0.13 Bar]
 Re-start 45 PSI [3.1 Bar] ± 2 PSI [0.13 Bar]

MATERIALS OF CONSTRUCTION:

Housings: Polypro
 Valves/Seals: EPDM
 Diaphragm: Santoprene
 Hardware: Stainless Steel

AGENCY APPROVALS:

Ignition Protection 8846, CE, IMCI Certified

SHIPPING INFORMATION:

Approx. Net Weight: 7.9 Pounds [3.5 Kg] ea.
 Carton Qty.: 6
 Approx. Carton Weight: 50 Lbs. [22.6 Kg]
 Approx. Carton Size: 24”L X 18”W X 6”H [61cm x 46cm x 15cm]
 Retail (individual) box: 12”L X 6”W X 6”H [30cm x 15cm x 15cm]

- Aftermarket model includes:**
- 50 Mesh strainer: swivel straight adapter ½-14 NPT (hex-wing nut) x ½-14 NPS (male)
 - Pistol grip plastic spray nozzle
 - Fittings: swivel straight adapter ½-14 NPT (hex-wing nut) x ¾ barb (Qty. 2)
 - Fitting: swivel straight adapter ½-14 NPT (hex-wing nut) x ¾ NHR (Male) (Qty. 1)

REPAIR KITS

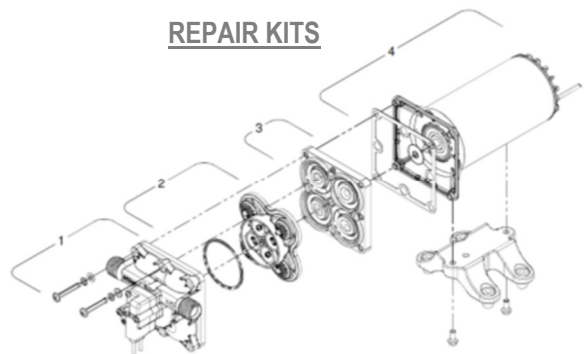

Number	Description	Part Number
*1	Upper Assembly	94-804-02
2	Valve Assembly	94-800-01
3	Drive Assembly	94-801-02
4	Motor/Gasket	94-71-001-03
*1,2,3	Pump Head	94-804-03
Not Shown	Check Valve	94-800-03

*With preset switch adjustment