

Dimensions

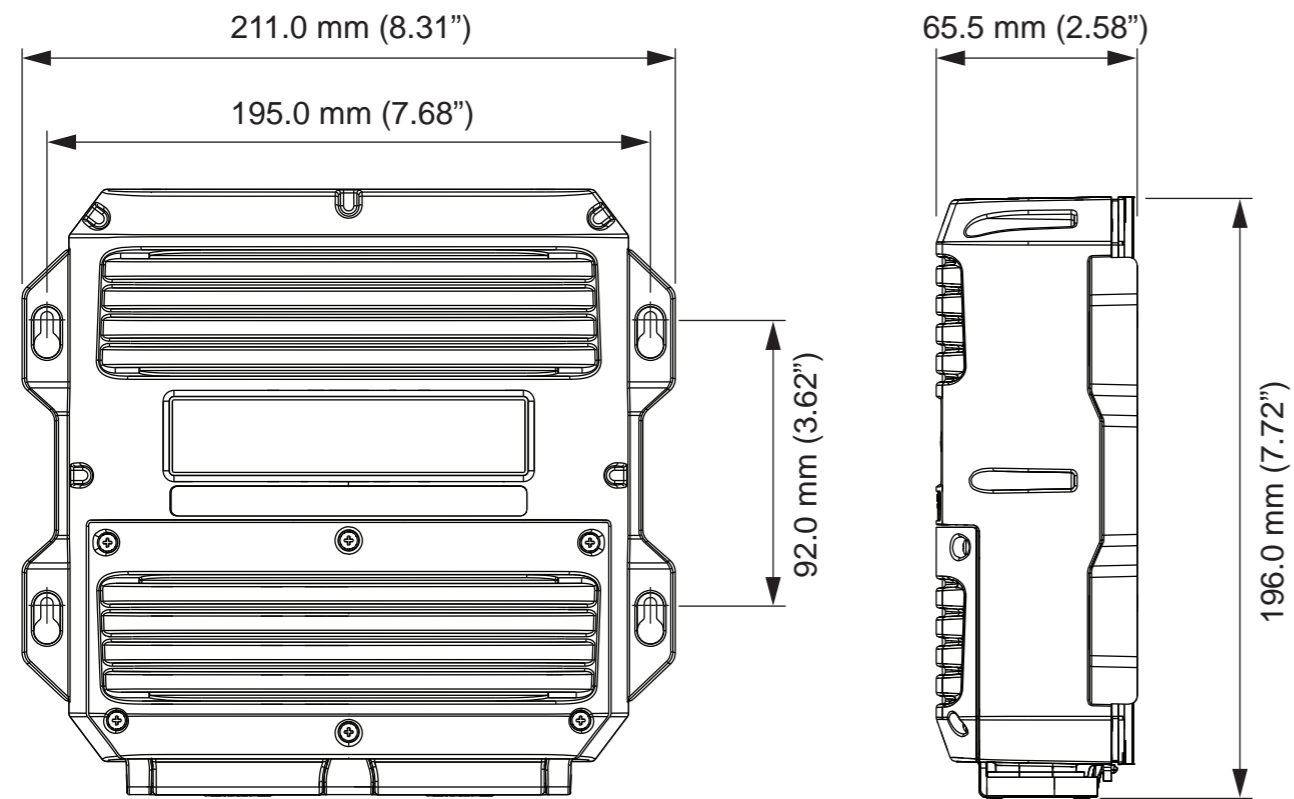

Mounting

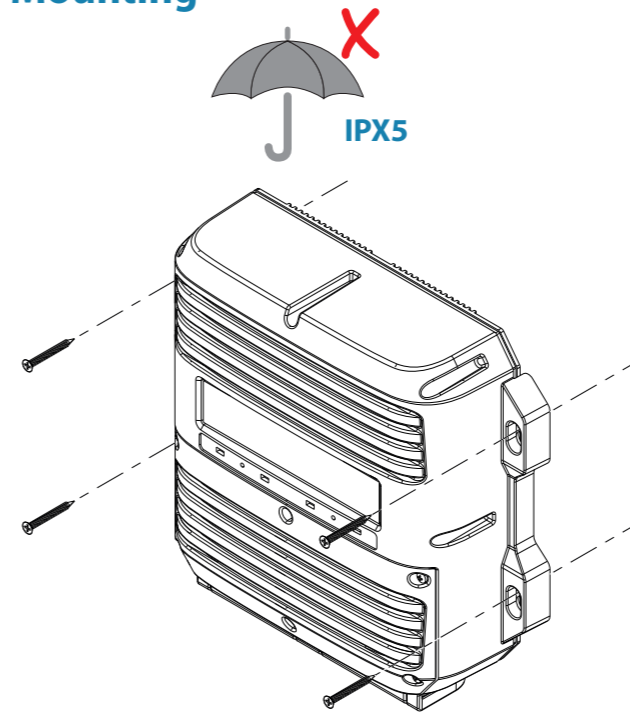

SIMRAD

B&G

NAC-3 AUTOPILOT COMPUTER INSTALLATION GUIDE

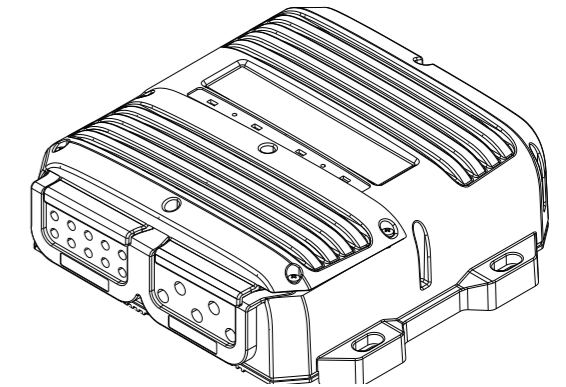

System wiring example

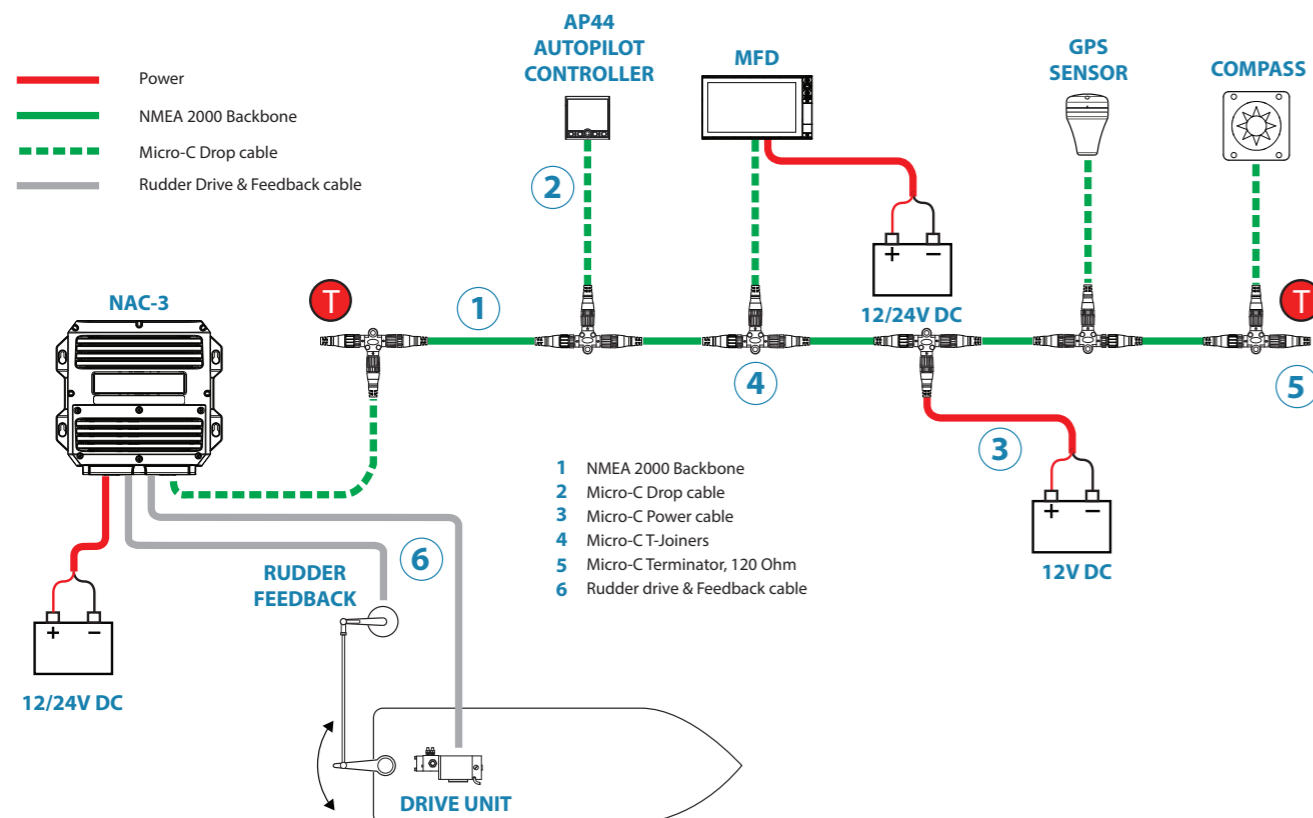

Parts included

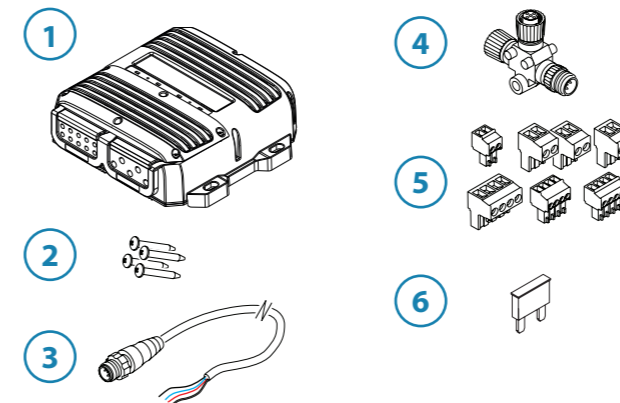

- 1 x NAC-3 Autopilot Computer - IPX5
- 4 x Fixing screws
- 1 x Micro-C Drop cable (male) - 0.6 m
- 1 x Micro-C T-Joiner
- 7 x Connectors
- 1 x 30 Amp fuse
- Warranty card & literature pack

Terminal access

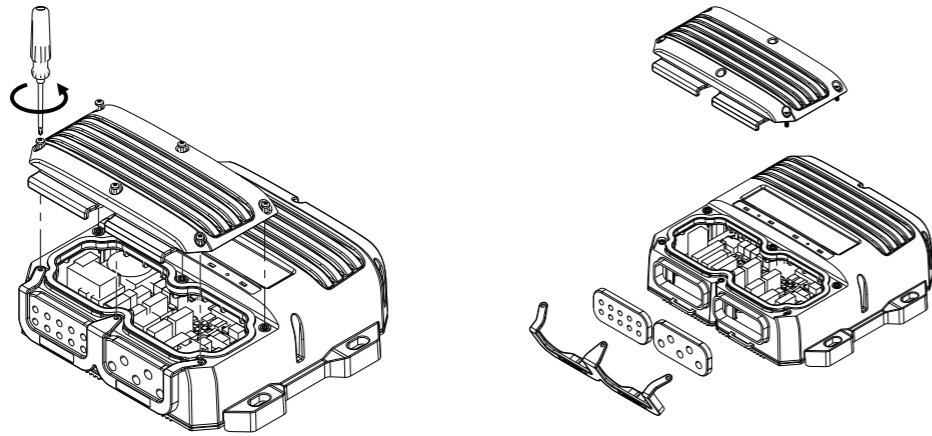

Terminal layout

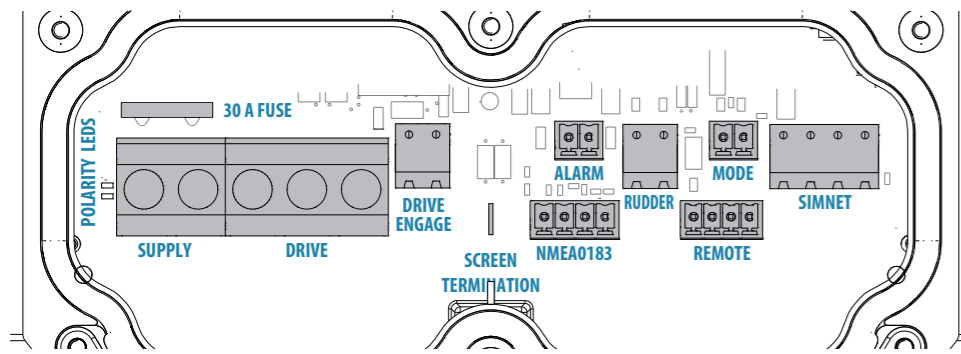

Grounding

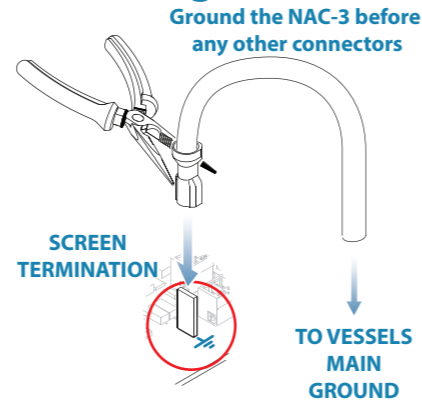

Drive units (Max 8A/12A Continuous/Peak)

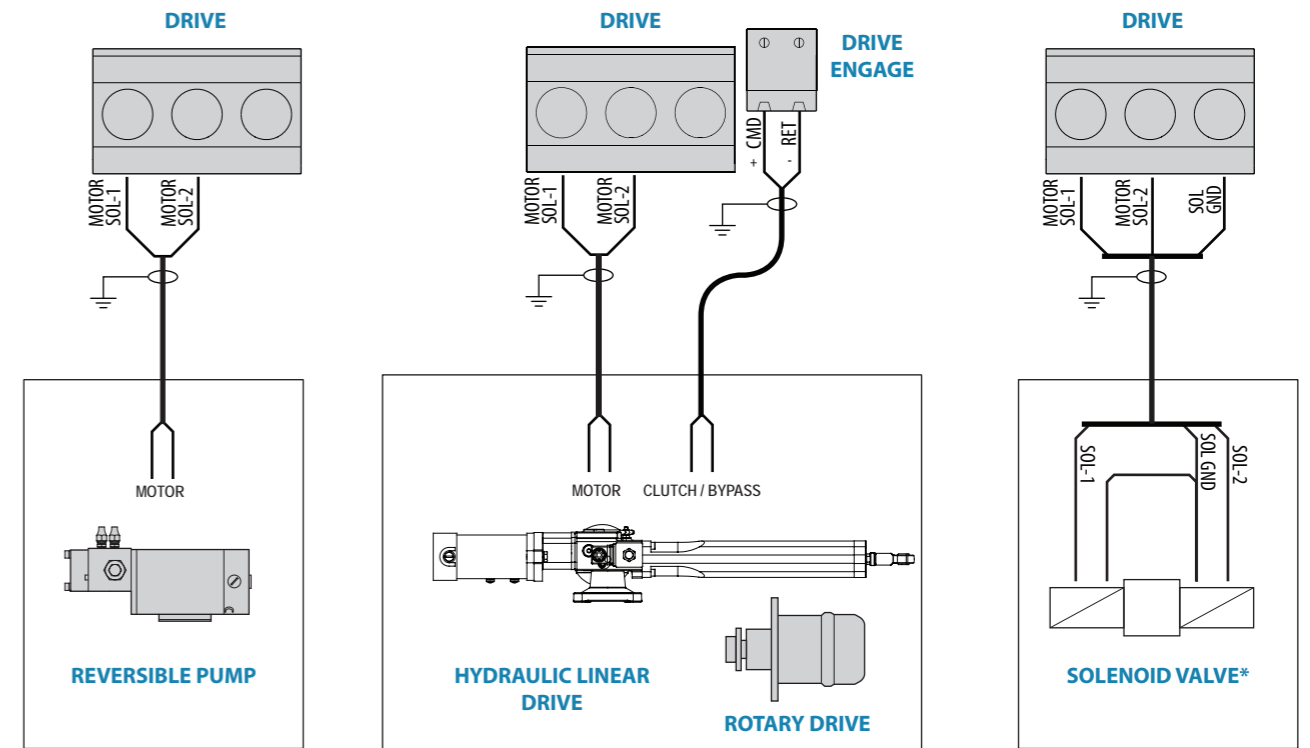

NOTE:
 NAC-3 Autopilot cannot operate externally powered solenoids unless installing isolating relays.
 NAC-3 Autopilot ne peut pas commander des électrovannes sans utiliser un relais isolé.
 NAC-3 Autopilot kann keine extern gespeisten Magnetventile ansteuern sofern keine isolierten Relais installiert sind.
 NAC-3 Autopilot kan ikke kobles mot magnetventiler med eksternt tilført spenning uten at man benytter eksterne releer.

* Solenoid valves, 12 or 24V DC, powered from NAC-3 Autopilot

Power

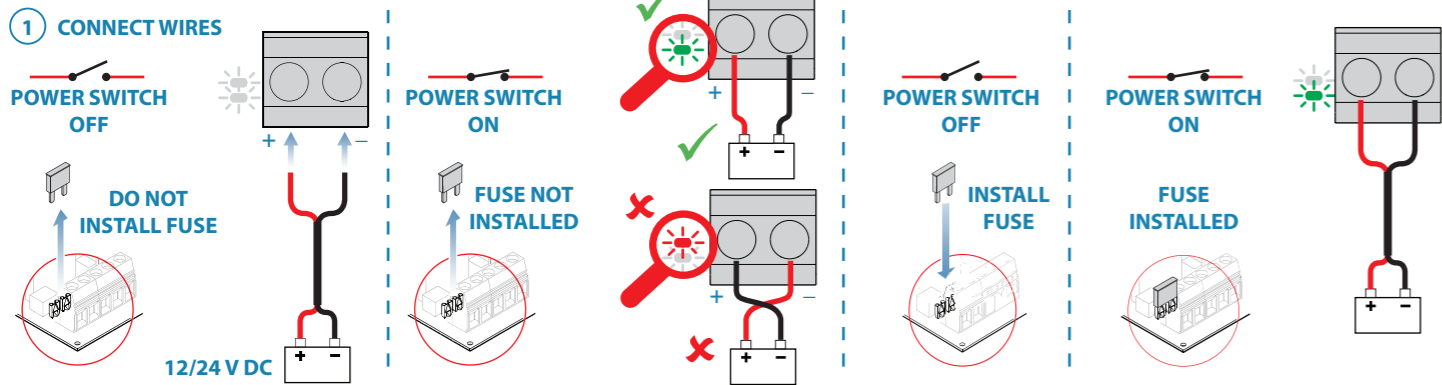

Rudder Feedback (Frequency rudder feedback)



External Alarm

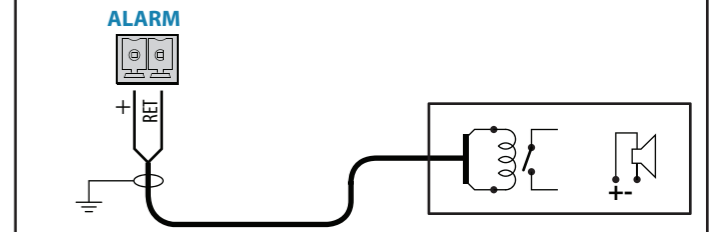

External System Selector

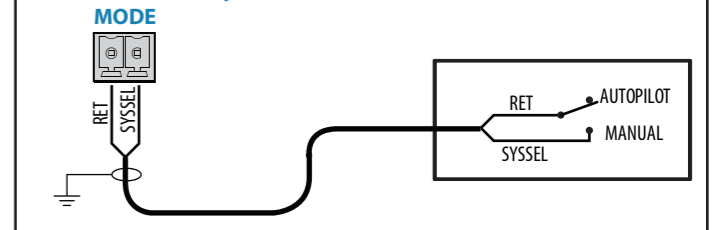

Network

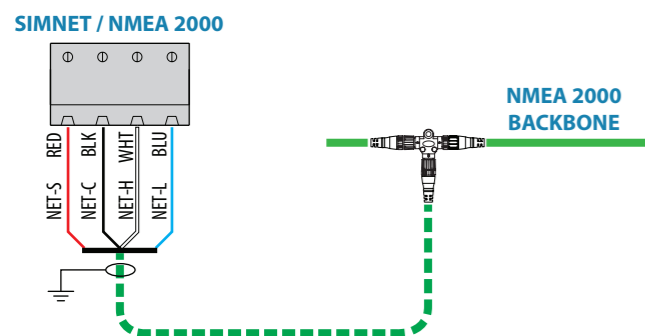

Remotes

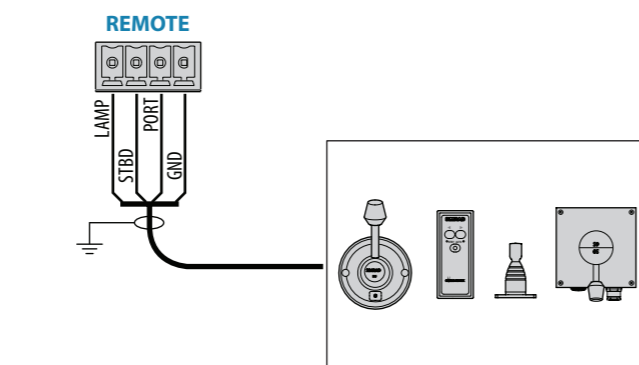

NMEA 0183

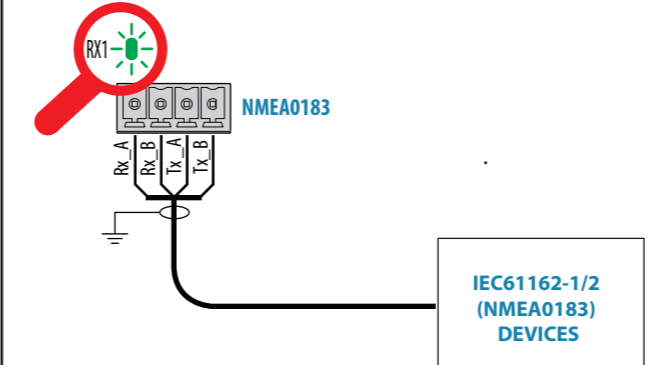

External I/O

