

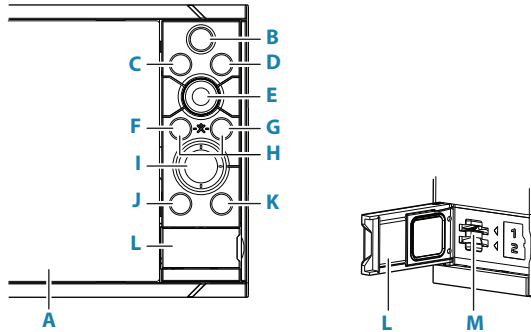

NSS evo3S Quick Guide



Front panel



A Touch Screen

B Pages/Home key

- Press to open the Home page for page selection and setup options.

C Wheel key user configurable key. Refer to the Operator manual.

Default without an autopilot connected to the system:

- Short press: toggles between panels on split screen.
- Long press: maximizes active panel on split screen.

Default with an autopilot connected to the system:

- Short press: opens the autopilot controller and puts the autopilot in standby mode.
- Long press: toggles between panels on split screen.

D Menu key

- Press to display the active panel's menu.

E Rotary knob

- Turn to zoom or scroll the menu, press to select an option.

F Enter key

- Press to select an option or save settings.

G Exit key

- Press to exit a dialog, return to previous menu level, and clear cursor from panel.

H MOB keys

- Press simultaneously the Enter and Exit keys to create a MOB (Man Over Board) at the vessel's position.

I Arrow keys

- Press to activate cursor or to move cursor.
- Press to navigate through menu items and to adjust a value.

J Mark key

- Press to place waypoint at vessel position, or at cursor position when cursor is active.
- Press and hold to open the Plot dialog from where you can add or manage waypoints, routes and tracks.

K Power key

- Press and hold: turns the unit ON/OFF
- Short press once: displays the System Controls dialog.
- Repeat short presses: toggles through preset dimming levels.

L Card reader door

M Dual card reader slots

Home page

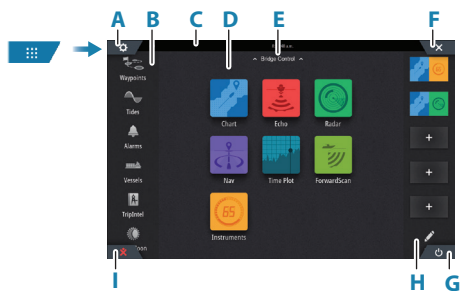

- A** Settings button
- B** Toolbar
- C** Status bar
- D** Application page buttons
- E** Bridge Control
- F** Close button, closes the current panel
- G** System Controls button
- H** Favorites bar
- I** Man Over Board (MOB) button

The MOB mark

To create a MOB mark:

- Press the MOB button.
- Simultaneously press the Enter and Exit keys.

To stop displaying navigational information to the MOB waypoint: cancel the navigation from the menu.

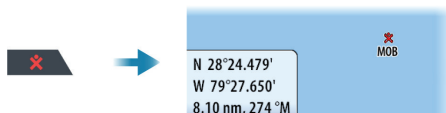

System Controls dialog

Used for quick access to system settings.

Activate the dialog by:

- Pressing the System Controls button.
- Swiping from the top of the screen.
- Pressing the Power key.

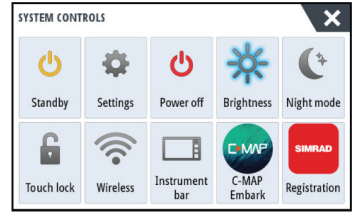

➔ **Note:** The content of the System Controls dialog depends on connected equipment and active panel.

Application pages

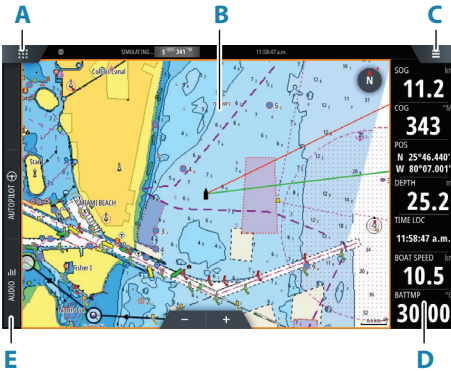

- A Home/pages button
- B Application panel
- C Menu button
- D Instrument bar
- E Control bar

Adjust panel size

You can adjust the panel sizes in a split page.

1. Tap the adjust split button in the System Controls dialog to show the resize icon
2. Drag the resize icon to set preferred panel size
3. Save the changes by tapping the screen.

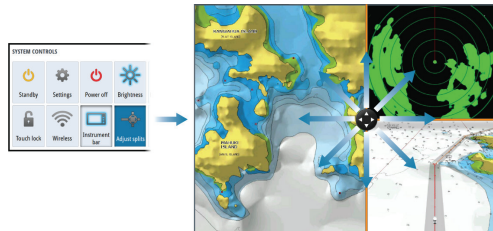

Charts

- Zoom the chart by using spread or pinch gestures or by using the zoom buttons.



- Move the view in any direction by panning the chart.
- Display information about a chart item by tapping the item.

Waypoints

To create a waypoint:

- Press the Mark key to instantly add a waypoint.
 - Select the new waypoint option in the menu.
- ➔ **Note:** With cursor inactive, the waypoint is placed at vessel's position. With cursor active, the waypoint is placed at selected cursor position.

Echosounder

- Zoom the image by using the zoom buttons.
- View echosounder history by panning the image.
- Adjust gain and color using the slide bar in the menu.
- Toggle auto gain ON/OFF from the menu.

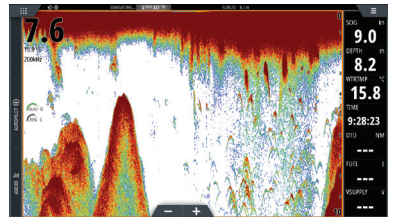

Autopilot

- Activate the autopilot controller from the Control bar.
- Select an autopilot mode by pressing the mode button from the Control bar.
- Switch to standby mode from the autopilot controller or by using a physical Standby key.

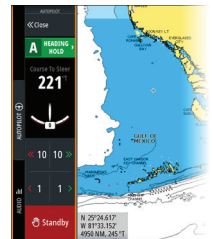

Radar

- Turn the radar transmitting ON/OFF from the menu.
- Adjust radar range by using the zoom buttons on the radar panel.

