

Remove old inlet's four mounting screws and remove the inlet from the boat. If the old inlet has a rear safety enclosure, loosen the strain relief clamp and remove.

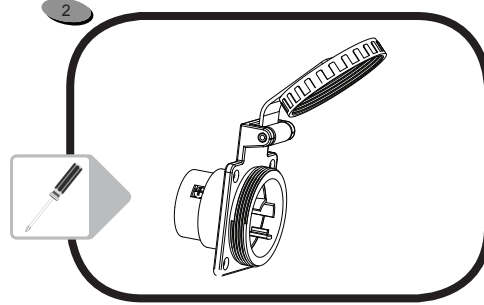

Loosen the screws on the side to disconnect the inlet from the boats internal wiring and remove the old inlet.

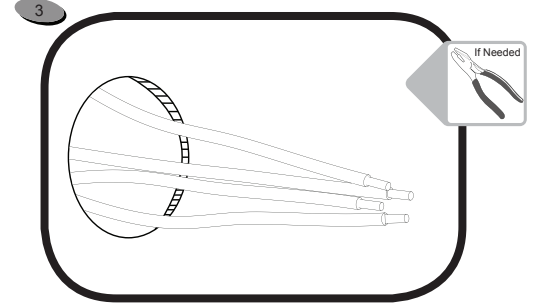

Examine the boats internal wiring. Make sure the wire is in good condition, a clean and bright copper color. If necessary, cut back until the clean wire is found.

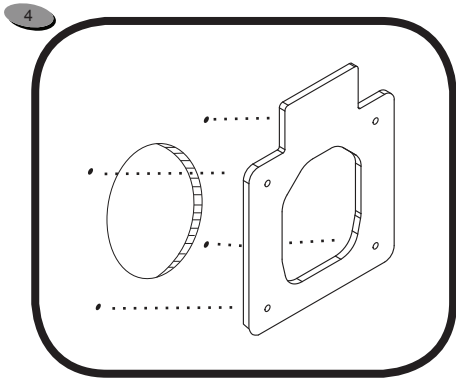

Test your new SmartPlug for proper fit and alignment of screw holes. (On some installations, you may have to modify the hole in your boat to accept the new plug. Please use the enclosed rear mounting gasket as template if necessary.)

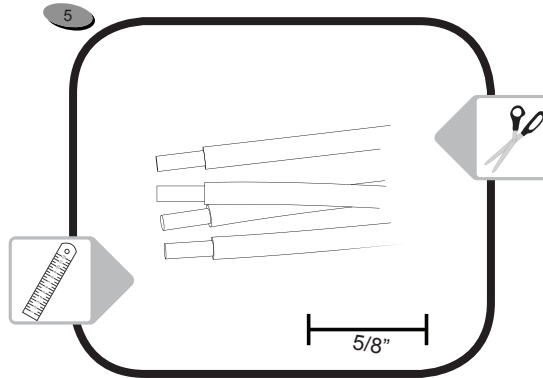

Strip the wire insulation back 5/8". Do not solder the end of the wire.

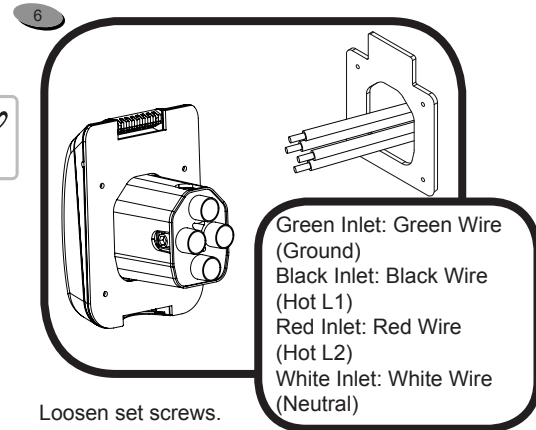

Loosen set screws.

Be careful not to back off too much. Twist bare copper wires into a tight and straight formation. Insert the bare wires into the corresponding color-coded terminals.

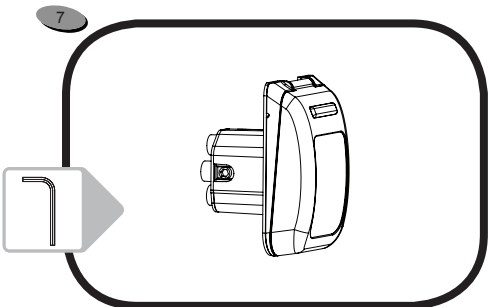

Make sure wire insulation butts up against corresponding color coded inlet. Tighten the screw clamp after each wire is inserted. Make sure there is no insulation inside the terminal clamp(s). Torque spec: 14-20lbs.

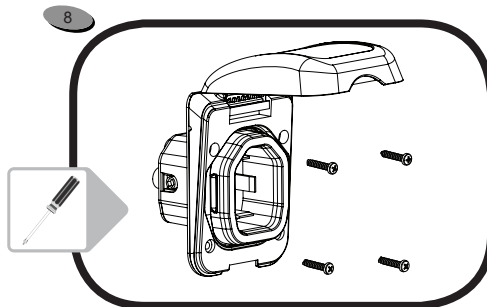

Reposition the new SmartPlug inlet in the *boat and out with the four screws from the old unit.

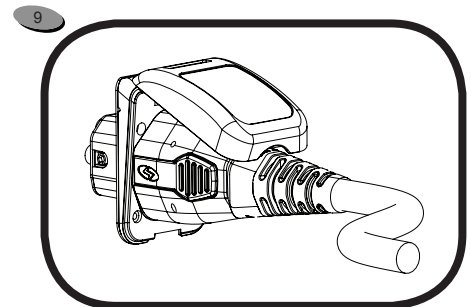

Insert plug into the inlet and press down on the inlet cover.

Note* If your installation requires using the strain relief component, bend all 3 wires flat so that they can be routed out one or more of the guides in the strain relief as shown. Screw strain relief onto back of inlet.

Materials Included

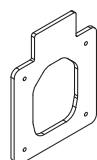

A. Rear Mounting Gasket (1)



B. SmartPlug Inlet (1)



C. Hex Key (1)