



PROPRIETARY ITEM - EXCEPT FOR USES EXPRESSLY GRANTED IN WRITING INFORMATION DISCLOSED HEREON IS CONFIDENTIAL AND ALL RIGHTS PATENT AND OTHERWISE ARE RESERVED BY SOUTHCO, INC.

F7 FLEXIBLE DRAW LATCH

DATE	DRAWN	CHKD	SCALE
12AUG94	MMM	RMP	NTS

DRAWING NUMBER
TD-F7-1-J

REV	DATE	DRAWN/CHKD	DESCRIPTION
B	5SEP00	GDM	SEE RECORD PRINT
C	09APR2002	GDM	UPDATE FORMAT
D	08JAN2004	MJS	SEE ENSTAR JOB 1298

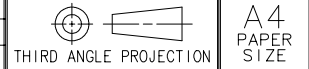

SOUTHCO PERFORMANCE GUIDELINES
THE PERFORMANCE GUIDELINES SHOWN ON THIS PAGE ARE SUPPLIED AS A GENERAL GUIDE ONLY, AS CONDITIONS VARY WITH EACH APPLICATION AND METHOD OF INSTALLATION. STRENGTH DATA GIVEN IS FOR FAILURE OF THE PRODUCT OR FOR SUFFICIENT DEFORMATION TO MAKE PRODUCT INOPERABLE. NO SAFETY FACTOR HAS BEEN APPLIED. IT IS RECOMMENDED THAT THE USER REQUEST A PRODUCT SAMPLE FOR TESTING TO DETERMINE THE SUITABILITY OF THE PRODUCT FOR THE PURPOSE INTENDED AND USER'S PARTICULAR APPLICATION.

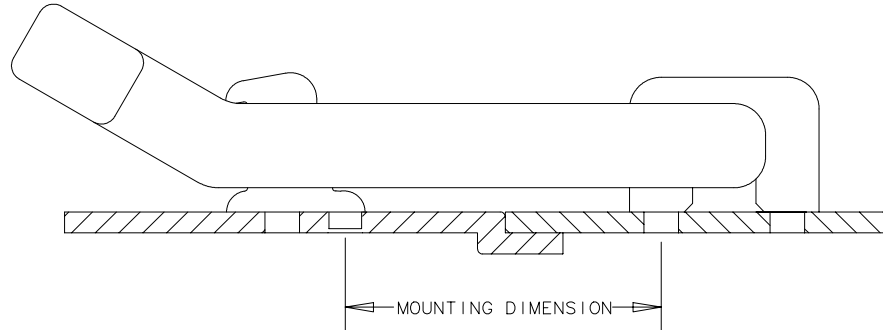

LATCH PART NUMBER F7-5XX

MOUNTING DIMENSIONS mm (inch)	AVERAGE CLAMPING FORCES VS TIME AND TEMPERATURE N (lbf)	
	23°C (73°F)	
	INITIAL ①	STEADY STATE ②
37.8 (1.5)	37 (8)	32 (7)
41.0 (1.6)	66 (15)	54 (12)
44.2 (1.7)	102 (23)	82 (18)
MAXIMUM TIGHTENING TORQUE N·m (lbf·in)		2.0 (18)
CYCLE LIFE		100,000 CYCLES

① THE INITIAL CLAMPING FORCE IS THE FORCE APPLIED TO THE PANEL WHEN HANDLE AND KEEPER ARE LATCHED.

② THE STEADY STATE CLAMPING FORCE IS THE DESIGN FORCE OF THE LATCH MEASURED AFTER THE INITIAL FORCE HAS RELAXED. THIS OCCURS OVER A TEST PERIOD OF APPROXIMATELY 24 HOURS AT ROOM TEMPERATURE.

southco®

PROPRIETARY ITEM - EXCEPT FOR USES EXPRESSLY GRANTED IN WRITING INFORMATION DISCLOSED HEREON IS CONFIDENTIAL AND ALL RIGHTS PATENT AND OTHERWISE ARE RESERVED BY SOUTHCO, INC.

FLEXIBLE DRAW LATCH - CONCEALED MOUNTING SUBASSEMBLY (FRONT MOUNTED)

DATE	DRAWN	CHKD	SCALE	DRAWING NUMBER
26MAY2009	MJS		1:1	J-F7-530

REV	DATE	DRAWN/CHKD	DESCRIPTION	ITEM	PART NUMBER	MATERIAL	COLOR
A	26MAY2009	MJS	INITIAL DRAWING RELEASE	SUBASSEMBLY	F7-530	-	-
				HANDLE	-	TPE	BLACK
				BRACKET	-	GLASS REINFORCED NYLON	BLACK

MILLIMETERS

ALL DIMENSIONS WITHOUT TOLERANCES ARE FOR REFERENCE ONLY.

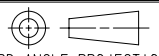

THIRD ANGLE PROJECTION

A4 PAPER SIZE

NOTES:

1. MOUNT USING (2) No. 10/M5 SCREWS OR 3/16 - 5mm RIVETS (NOT SUPPLIED).
2. NOTED DIMENSIONS ARE NOT TO SCALE AND REPRESENT DISTANCE WHEN FLEXIBLE DRAW LATCH HANDLE IS STRETCHED TO LATCHED POSITION OVER THE KEEPER.

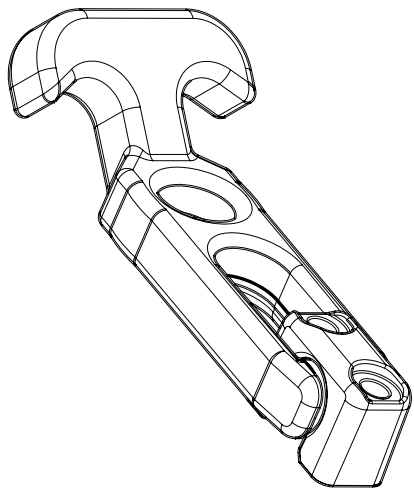
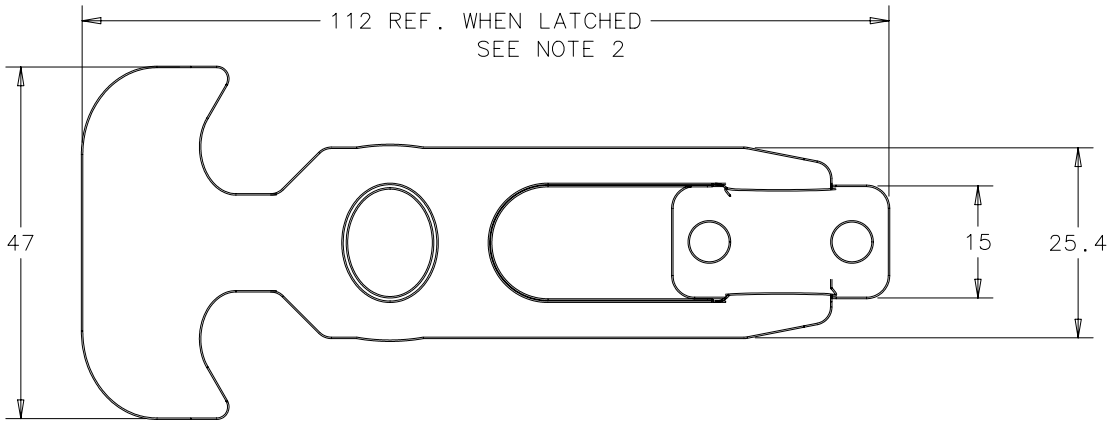

SCALE .75:1

