

southco[®]

PROPRIETARY ITEM - EXCEPT FOR USES EXPRESSLY GRANTED IN WRITING INFORMATION DISCLOSED HEREON IS CONFIDENTIAL AND ALL RIGHTS PATENT AND OTHERWISE ARE RESERVED BY SOUTHCO, INC.

FLUSH PULL LATCH

DATE	DRAWN	CHKD	SCALE	DRAWING NUMBER
13MAY93	ALC	ACZ	NTS	TD-M1-1-J

REV	DATE	DRAWN/CHKD	DESCRIPTION
F	11FEB03	GDM	ADDED M1-25

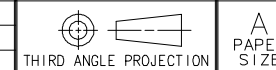

SOUTHCO PERFORMANCE GUIDELINES
 THE PERFORMANCE GUIDELINES SHOWN ON THIS PAGE ARE SUPPLIED AS A GENERAL GUIDE ONLY, AS CONDITIONS VARY WITH EACH APPLICATION AND METHOD OF INSTALLATION. STRENGTH DATA GIVEN IS FOR FAILURE OF THE PRODUCT OR FOR SUFFICIENT DEFORMATION TO MAKE PRODUCT INOPERABLE. NO SAFETY FACTOR HAS BEEN APPLIED IT IS RECOMMENDED THAT THE USER REQUEST A PRODUCT SAMPLE FOR TESTING TO DETERMINE THE SUITABILITY OF THE PRODUCT FOR THE PURPOSE INTENDED AND USER'S PARTICULAR APPLICATION.

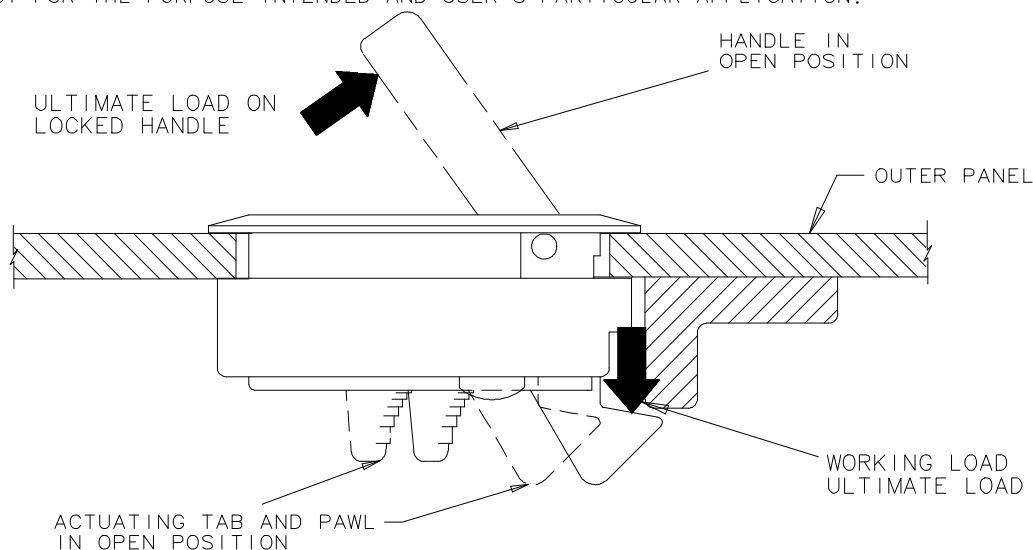

PART NUMBER	MOUNTING SCREW SIZE	MAX RECOMMENDED WORKING LOAD [Ⓐ]	AVERAGE ULTIMATE LOAD [Ⓑ]	MAX RECOMMENDED TIGHTENING TORQUE ON MOUNTING SCREW	AVERAGE ULTIMATE LOAD ON LOCKED HANDLE (LOCKABLE VERSION ONLY) [Ⓒ]
M1- $\frac{4}{6}$ X M1- $\frac{4}{6}$ X-1 M1- $\frac{4}{6}$ X-7	M5	270 N (60 lbf)	445 N (100 lbf)	2.8 Nm (25 lbf·in)	90 N (20 lbf)
M1- $\frac{4}{6}$ X-8		835 N (187 lbf)	1265 N (284 lbf)		2520 N (557 lbf)
M1-25- $\frac{4}{6}$ X-X8		1035 N (232 lbf)	1530 N (344 lbf)		1580 N (355 lbf)

- [Ⓐ] WORKING LOAD is the maximum recommended load at which the product continues to function properly.
- [Ⓑ] ULTIMATE LOAD is the load that causes excessive pawl deformation, which renders the product inoperable.
- [Ⓒ] AVERAGE ULTIMATE LOAD ON LOCKED HANDLE is the load which is necessary to force open the handle when locked.

REF:M1-04,12,38

NOTES:

A. MATERIAL AND FINISH:

- PAWL, HANDLE, HOUSING - CF-8M STAINLESS STEEL (NOMINAL CAST EQUIVALENT OF 316 STAINLESS STEEL), POLISHED
- BRACKET, KEEPER SPRINGS, SCREW - 304 STAINLESS STEEL, POLISHED
- PIN, LOCKING LEVER SPLINE LOCKPLUG - 304 STAINLESS STEEL, PASSIVATED
- SPACER KEY - NYLON, BLACK - BRASS, CHROME PLATED

B. STYLE AND FINISH:

- X = STYLE
- 4 = LOCKING
- 6 = NON-LOCKING
- Y = FINISH
- 8 = BRIGHT POLISH



PROPRIETARY ITEM - EXCEPT FOR USES EXPRESSLY GRANTED IN WRITING INFORMATION DISCLOSED HEREON IS CONFIDENTIAL AND ALL RIGHTS PATENT AND OTHERWISE ARE RESERVED BY SOUTHCO, INC.

1-1/2" SLAM LATCH
STAINLESS STEEL

DATE	DRAWN	CHKD	SCALE	DRAWING NUMBER
18OCT2007	RLR	BPV	1:1	J-M1-15-61

REV	DATE	DRAWN/CHKD	DESCRIPTION
A	21OCT2014	CMS/MWD	PRN: P2014-2126

MILLIMETERS [IN]
ALL DIMENSIONS WITHOUT TOLERANCES ARE FOR REFERENCE ONLY.
THIRD ANGLE PROJECTION
A3 PAPER SIZE

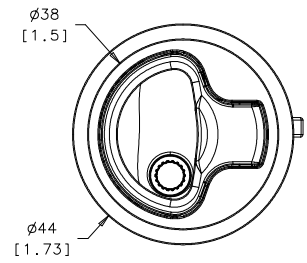
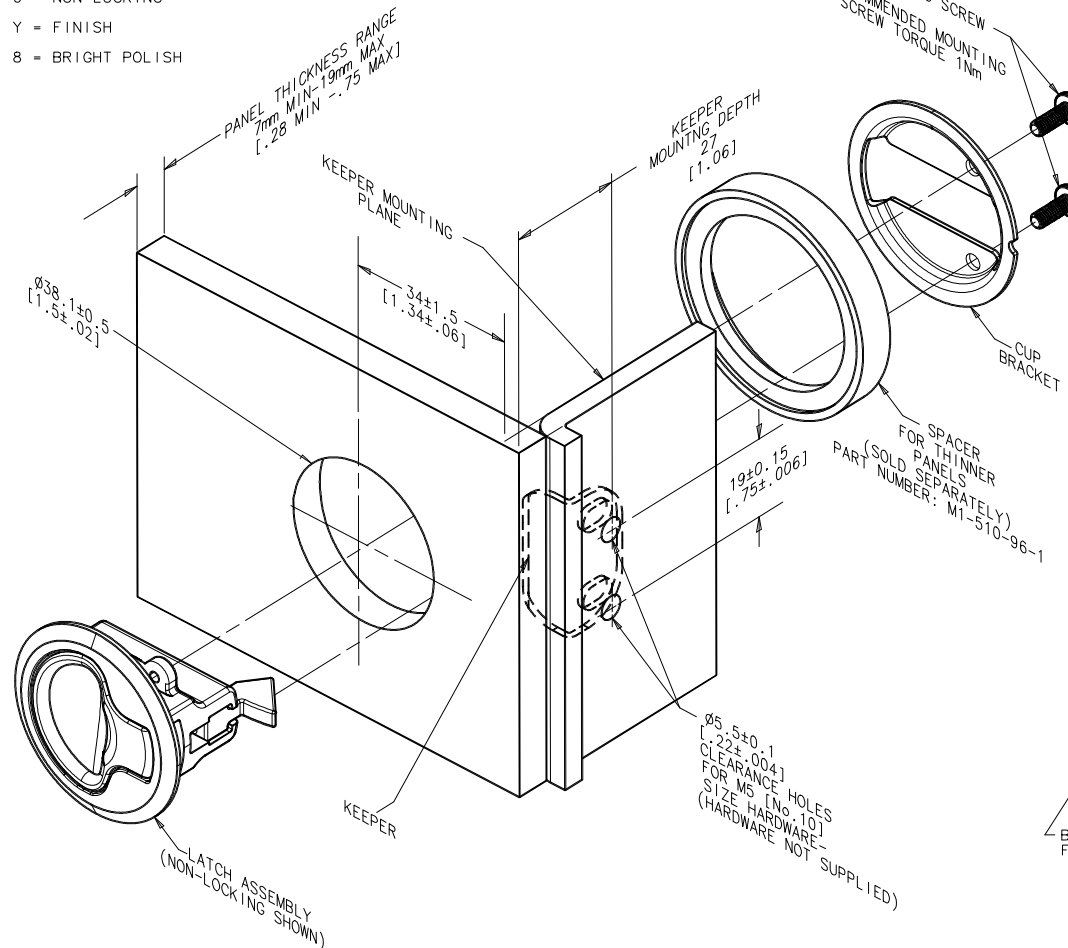

KEY LOCKING VERSION
PART NUMBER: M1-15-41-Y

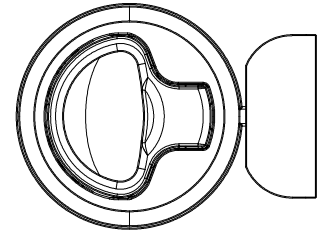

NON-LOCKING VERSION
PART NUMBER: M1-15-61-Y

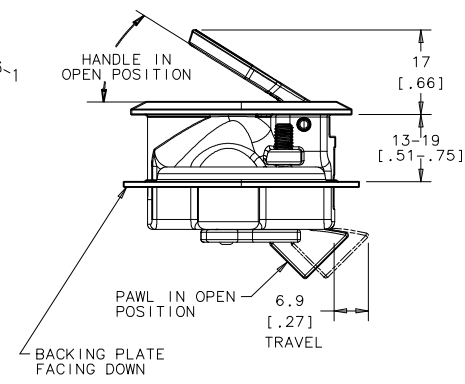
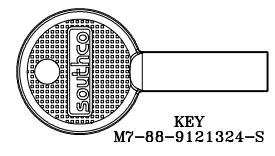

LOCKING VERSION
SHOWN

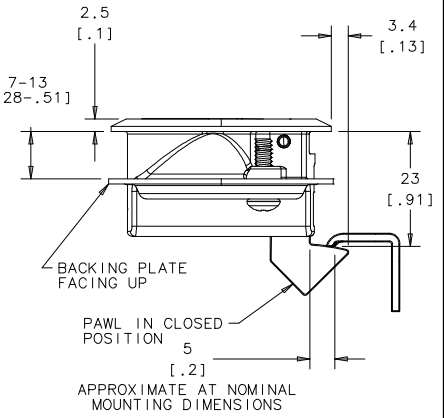

NON-LOCKING VERSION
SHOWN

Looking for dependable boat cabin and galley? Rely on Southco for quality and long-lasting products.