

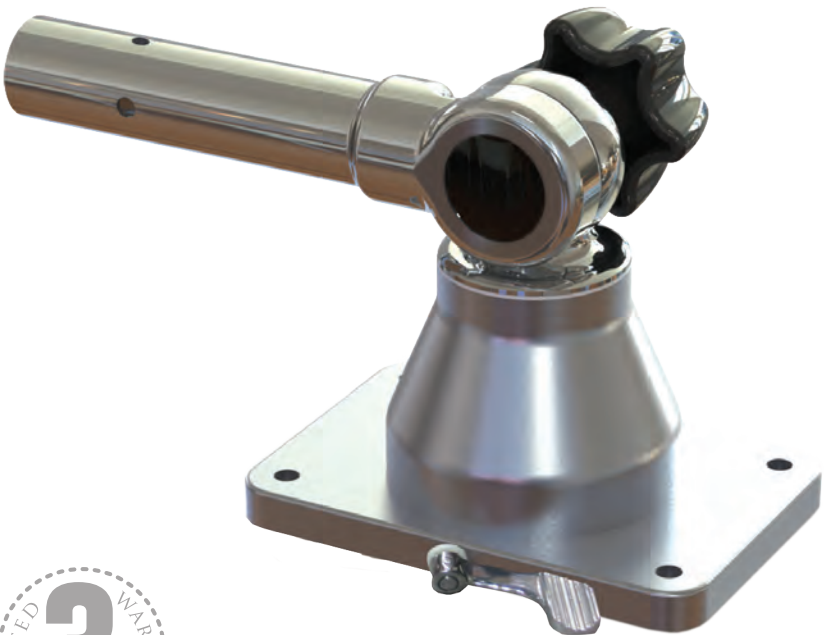

Grand Slam 170 and Grand Slam 170-2 Installation Instructions



Thank you for purchasing a quality Taco Marine product. As a family-owned business since 1959, Taco Marine takes pride in offering the highest quality products with excellent customer service. We stand behind our products 100%.

CONTENT

**GS-170 SOLD IN PAIRS (FOR TELE-OUTRIGGERS) OR
GS-170-2 SOLD AS EACH (FOR CENTER RIGGER)**

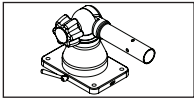

A: 2 - GS-170 Mount
A: 1 - GS-170-2 Mount

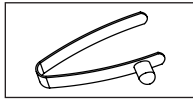

B: 2 - Locking Clip
B: 1 - Locking Clip

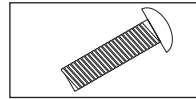

C: 8 - 5/16 x 18 x 1-1/2" Bolt
C: 4 - 5/16 x 18 x 1-1/2" Bolt



D: 8 - 5/16 x 18 Nut
D: 4 - 5/16 x 18 Nut



E: 8 - Plastic Washer
E: 4 - Plastic Washer



F: 8 - Stainless Washer
F: 4 - Stainless Washer



G: 8 - Stainless Lock Washer
G: 4 - Stainless Lock Washer

Tools Needed:

Electric Drill with 3/8" Drill Bit • 3/16" Allen Wrench • 1/2" Box Wrench

INSTALLATION OF YOUR NEW GRAND SLAM 170 OUTRIGGER BASE ON A T-TOP (CANVAS TOP)

Figure 1

When installing the Grand Slam mount on a canvas top (**see Figure 1**), a mounting plate must first be installed running forward and aft on each side between the brace bars of the T-Top for additional structural support. If there is no mounting plate, contact your local retailer for details or marine aluminum fabricator to have plates welded in your Canvas T-Top. If you are having plates made, they should be 3/8" thick by 5" wide and long enough to fit between the brace bars. Weld the plates to the frame and brace bars. The mounting plates should be welded on 3 sides.

Mark the location of the 4 mounting holes right through the holes in the unit or using the provided GS-170 Drill Template. (**Note: Before using the drill template provided, please ensure dimensions are accurate.**)

On the underside of the GS-170 mount put a bead of Silicone around all 4 holes of the unit and place on top of the canvas directly over the holes in the plate, insert the bolts and tighten with a 3/16" Allen Wrench. **Do not add silicone in the center groove line under the plate as this line acts as a drain for the inside part of the mount.** If mounting to a hardtop see illustration **Figure 2**.

Figure 1

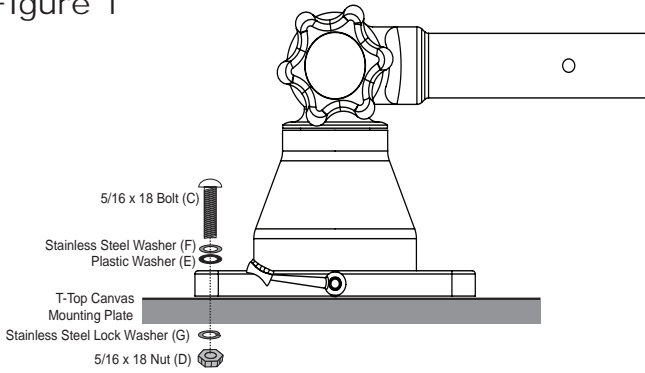

HARD TOP

Figure 2

For a Hard Top installation, align the mounts in the desired position. See guide of Top Mount Orientation for GS-170 Outriggers in the installation instructions on page 4. Mark desired position and holes for mounting the GS-170 using the mount or the provided drill template. **(Note: Before using the drill template provided, please ensure dimensions are accurate.)**

Using a 3/8" drill bit drill out each corner hole for the mount. Put a bead of silicone on the underside of the footprint around each mount bolt hole of the GS-170 unit and around the lower body. **Do not add silicone in the center groove line under the plate as this line acts as a drain for the round part of the mount.** For a soft core or hollow core hard top, drill each hole with a 7/16" drill bit. Measure the thickness of the hard top and decide if longer bolts are necessary. This will vary depending on the thickness of the Hard Top.

Figure 2

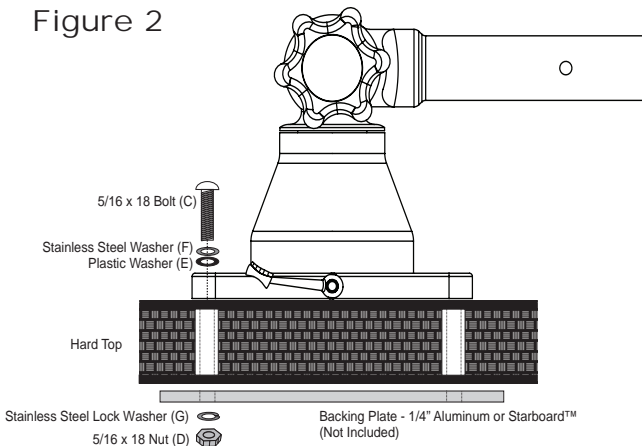

TOP MOUNT ORIENTATION

Mount orientation on top with adjustment knob/lever facing outboard

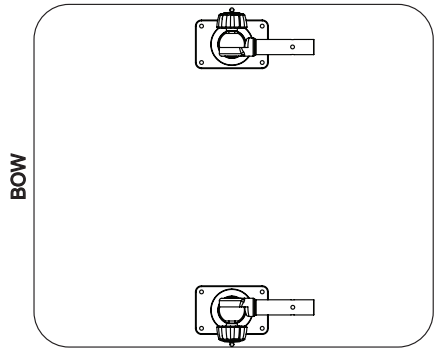

INSTALLING TACO MARINE TELE-OUTRIGGERS

Included with your Taco Marine GS-170 are a pair of stainless steel locking clips (single locking clip included in the GS-170-2). These clips are inserted as shown, make sure the button aligns with the hole in the butt end of the outrigger. This button will align with the hole in the tube on the Taco Marine GS-170 to lock the outrigger in place. To remove the outrigger depress the button and pull out the outrigger.

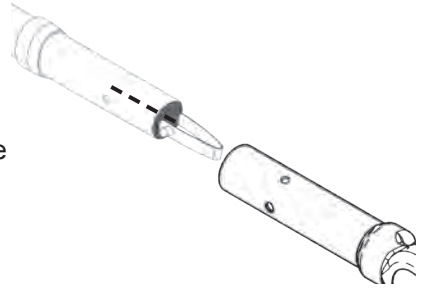

SOLD SEPARATELY:

Taco Marine GS-170 uses a 1-1/8" Outrigger.

Taco Marine part numbers for Outrigger Poles are:

OT-0441BKA15 - 15' Black with Gold rings and tips

OT-0441VEL15 - 15' Silver with Gold rings and tips

OT-0442BKA15 - 15' Black with Silver rings and tips

OT-0442VEL15 - 15' Silver with Silver rings and tips

Taco Marine part numbers for Center Rigger Poles are:

OC-0421BKA8 - 8' Black with Gold rings and tips

OC-0421VEL8 - 8' Silver with Gold rings and tips

OC-0422BKA8 - 8' Black with Silver rings and tips

OC-0422VEL8 - 8' Silver with Silver rings and tips

OC-0432BKA116 - 12' Black with Silver rings and tips

OC-0432VEL116 - 12' Silver with Silver rings and tips

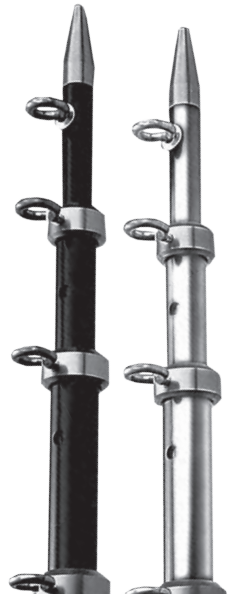

USING THE GS-170

The operation of the Taco Marine GS-170 is very straight forward. To raise and lower the outrigger, hold the outrigger securely to prevent it from falling, loosen the outrigger locking knob about 1 to 2 revolutions counterclockwise (**Figure 3**). The knob has a stop to prevent it from traveling beyond that point, **do not force the knob past the stop or you will damage the unit**. Lift the outrigger into the fishing position and tighten the locking knob. Make sure the locking splines are engaged while tightening the knob. The splines use a taper style lock, so when you loosen the locking knob apply back pressure to the outrigger to allow it to release. To rotate the head outward, rotate the locking lever to the vertical position (**Figure 4**), this will release the lock. Rotate the outrigger into the desired fishing position, when in position rotate the locking lever to a non vertical position to lock it into position, the locking positions are every 15°. It may be necessary to move the rotation slightly to allow the lock to engage. **Do not force the lock it should engage smoothly.**

Figure 3

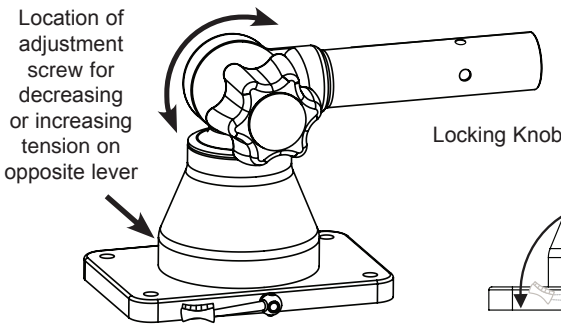
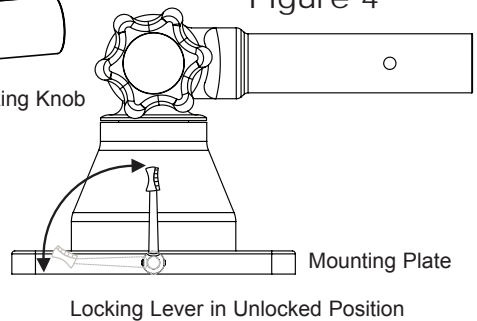

Figure 4



CARE OF YOUR TACO MARINE GS-170

Use marine grade boat soap to wash your GS-170 Mount(s) and outriggers thoroughly and rinse them with fresh water after each use. **Do not wax or use caustic cleaning agents on any of the components as that promotes corrosion.** It is recommended that you use a Marine grade lubricants such as CRC corrosion inhibitor lightly sprayed on any moving parts. This will minimize the chances of corrosion it also blocks out dirt or salt. Wipe any excess lubricant clean from the mount.

Taco Marine Standard Rigging Kit

- Glass Ring Shock Cord w/Brass Snap Clip
- 1/8" thick, 100' Dacron Rigging Cord in Black
- Adjustable Tension Release Clip
- Round Balsa Wood Stop
- Pad Eye & Pad Eye Screws
- Double Sleeve Crimp
- Swivel
- Snap Swivel
- Quick Dry Mesh Bag



Taco Marine Outrigger Line Caddy

- Eliminates tangling
- Rugged nylon



Taco Marine Backing Plate

- Additional support when mounting to hard tops or canvas tops
- Sold in Pairs



Taco Marine Wedge Plate

- Injection molded plastic
- Ideal for curved t-tops
- Sold in Pairs



Taco Marine Extrusion Plate

- Pre-drilled for easy mounting
- Conceals wiring
- Sold in Pairs



Taco Marine Tele-Outriggers

- Telescopes to less than 6' for bridge clearance, trailering and storage
- Used with mounts that accept 1-1/2" or 1-1/8" Outriggers
- Sold in Pairs

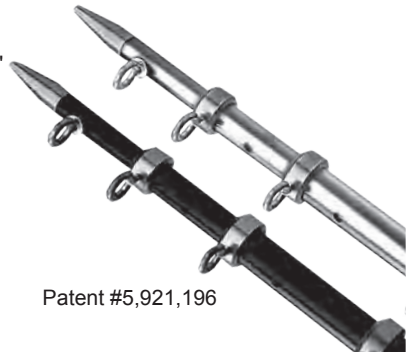

Patent #5,921,196

GS-170 DRILL TEMPLATE

Note: If printing from website, please print at 100% for accurate sizing. Slight scaling may still occur. Therefore, before drilling, it is recommended that all template dimensions are measured for accuracy. Use as a drilling template only after dimensions have been confirmed.

