

SUPRO-FLEX

INSTALLATION INSTRUCTIONS FOR SUPROFLEX RUB RAIL KITS

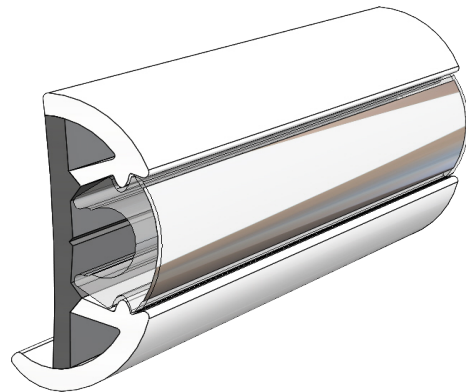

V11-9960

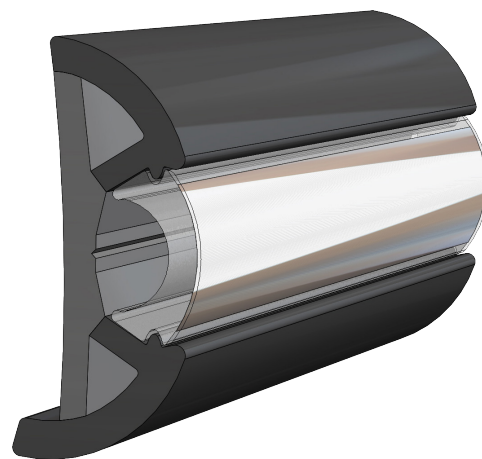

V11-9990

KIT CONTENTS

1

SuproFlex Rub Rail

1

Insert

8

Screws

2

End Caps

Required*

*not included

- TAPE MEASURE
- CAULKING GUN WITH SILICONE SEALANT
- MASKING TAPE & MARKER
- MITER BOX & HAND SAW
- PUTTY KNIFE
- VARIABLE SPEED, REVERSIBLE DRILL WITH APPROPRIATE DRILL BITS FOR REMOVAL AND INSTALLATION

TACO®

Handy Tips

- Once the rub rail comes in contact with the hull, stop tightening the screw!
- Over-torquing the screws can cause the rub rail to become disfigured.
- When making splices, make sure the ends are cut straight and smooth.

SUPROFLEX

Thank you for purchasing TACO Marine's SuproFlex Rub Rail! As a family-owned and operated business since 1959, we take pride in offering the highest-quality, innovative products with excellent customer service. We stand behind our products 100 percent.

REMOVAL OF OLD RUB RAIL & HULL PREPARATION

- 1) Remove the end caps.
- 2) Remove the insert and the stiffening strip, if there is one.
- 3) Remove the screws or rivets that attach the rub rail to the hull. If the rub rail is fastened with pop rivets, drill out the rivet head and push the shaft in to prevent rattling.
- 4) Remove the rub rail.
- 5) Use a putty knife to scrape off any old sealant, being careful not to scratch the gelcoat (it is unnecessary to remove all the old sealant, just the excess).
- 6) Fill all holes with marine-grade sealant/3M 5200 (you will be drilling new holes for the new rub rail).
- 7) Let the sealant cure according to the manufacturer's suggestions.

INSTALLATION

When cutting, use a miter box to ensure the rub rail you are installing has a straight end.

RUB RAIL

- 1) Stretch the rub rail when installing
 - a. Find the center section of the rub rail. Secure with two screws, 2" apart on each side of the bow
 - b. Drape the rub rail down each side of the installed rub rail on the cap or floor
 - c. Stretch rub rail under the cap to follow the hull side, or
 - d. Stretch rub rail over the gunnel to the securing point of the transom
 - e. Stretch the rub rail tight and insert two screws, 2" apart, about 4" forward of the transom turn
 - f. Once the rub rail is secured in both locations, pull the rub rail to cover the cap area.
NOTE: This should allow a very tight and straight installation
 - g. Scribe a line for the top of the rub rail to follow
 - h. Drill a pilot hole into the boat cap, using the pre-drilled holes in the rub rail as a guide
 - i. Install the #8 truss-head or pan head screws, using recommended pressure
NOTE: Many installers will use marine-grade sealant behind the rub rail or on the screws to seal
 - j. Repeat this same operation on the opposite side
NOTE: Ensure the amount of stretch from the first side is the same distance on the second side
- 2) Use 1", #8 Truss Head or Pan-Head Screws only.*
***DO NOT USE COUNTER SINK SCREWS**
- 3) It is recommended to use a CLUTCH GUN if available (This will control the pressure put onto the rub rail base more accurately).
- 4) If using a TORQUE DRILL GUN:
 - a. Set the torque of the drill gun to stop at surface touch of the rub rail (This is generally around setting 5 or 6 on an 18-Volt Cordless Drill).
 - b. It is not necessary or recommended to apply pressure beyond touching the surface



FLEX CHROME INSERT (V12-0307CP) INSTALLATION

Do not use heat to install the insert - It is not needed.

- 1) Find the center section of the insert
- 2) Drape the insert down each side of the installed rub rail on the cap or floor
- 3) Set the bottom leg of the insert into the bottom groove inside the rub rail
- 4) Tap the insert with a rubber/dead-blow hammer with enough force to seat the insert
- 5) Complete this all the way to the transom end
- 6) Repeat this same operation on the opposite side
- 7) Trim excess insert 1/8" past the rub rail
- 8) Install TACO stainless steel end caps

STAINLESS STEEL SUPROFLEX SMALL END CAP (F16-0274)

- 1) Mark and trim the end of the rub rail at the end of the rub rail run.
NOTE: This cut should be made flush to the edge of the boat's surface where the rub rail ends.
- 2) Place the end cap on the perpendicular surface to the rub rail with the edges of the end cap covering the trimmed end of the rub rail.
- 3) The protruded edge of the end cap should cover the trimmed edge of the rub rail.
- 4) Mark the hole openings in the end cap with a marker.
- 5) Remove the end cap and drill pilot holes where the marks were made.
NOTE: Ensure the drill bit used for making the pilot holes is smaller than the fastener/screws used to secure the end cap.
- 6) Apply marine-grade sealant between the end cap and boat's surface.
- 7) Place the end cap back in position, covering the trimmed rub rail end and surface edge.
- 8) Secure the end cap with stainless-steel fasteners/screws through each hole.



SUROFLEX RUB RAIL INSTALLATION DIAGRAM

1. Find the center point of rub rail and drape it down each side of the boat.

2. Install two anchor #8 Truss-Head Screws 2" apart before bend around transom.

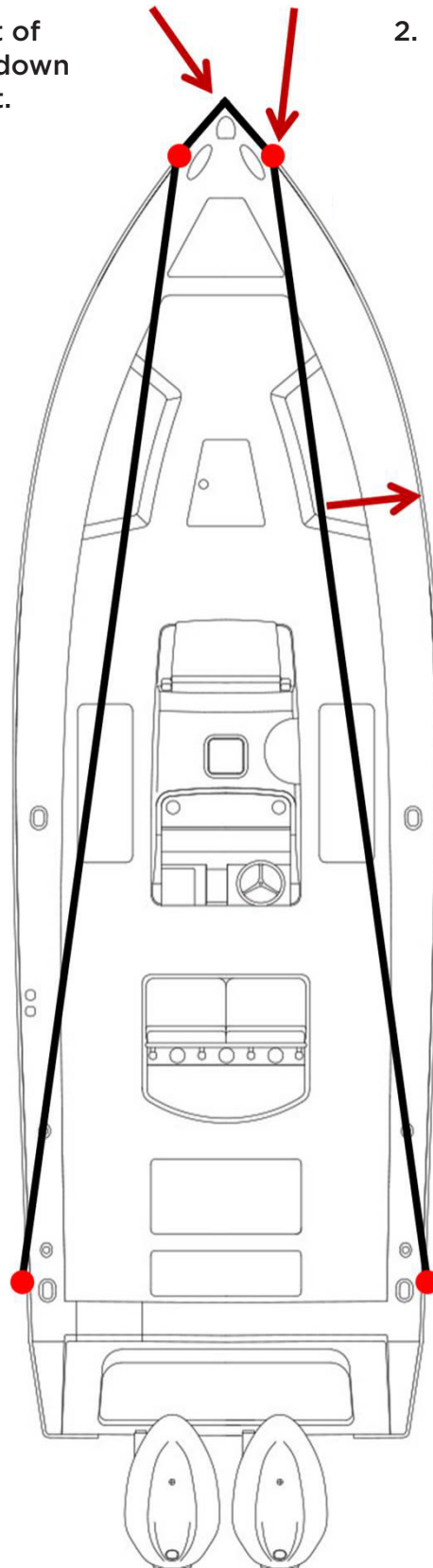

3. Once the rub rail is stretched and secured from the bow to the stern, pull the rub rail to cover the cap joint. This will help in providing a tight, straight line.

TACO[®]
MARINE

Check out the collection of boat hull and keel protectors we offer.