

Heavy Duty Side Mount Spare Tire Carrier



best in the
LongRun

Installation Instructions Part #86060

This kit contains the following components:

#	Qty.	Part #	Description
1	1	70305	Spare Tire Carrier
2	1	70305-3	Backing Plate
3	3	10863	Carriage Bolts 1/2"-20 x 1-3/4"
4	3	10640	Bolt Retainer 1/2"
5	3	10641	Lug Nuts 1/2"-20

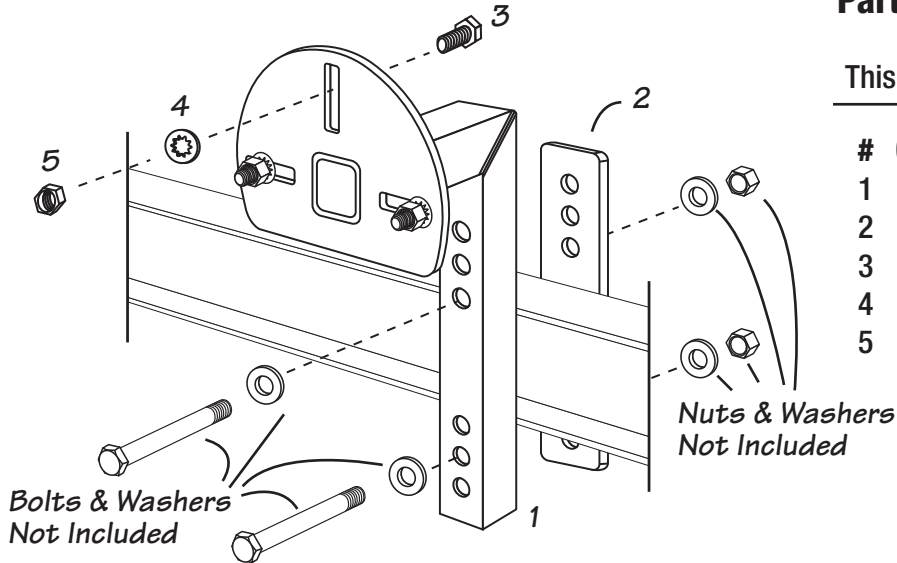

Must Purchase Separately (Choose One):

Zinc Plated Mounting Hardware

- 2 - 5/8" Grade 5 Hex Head Bolts
{length determined by frame width}
- 2 - 5/8" Grade 5 Nyloc Nuts
- 4 - 5/8" Washers

Galvanized Mounting Hardware

- 2 - 5/8" Grade 5 Hex Head Bolts
{length determined by frame width}
- 2 - 5/8" Grade 5 Nuts
- 2 - 5/8" Lock Washers
- 2 - 5/8" Washers

Mounting Instructions

1. Using the spare tire carrier and spare tire as a guide, determine a suitable mounting location on trailer frame.
2. Slide Grade 5 hex head bolt and washer (not included) through front (top) tire carrier, over the frame and through the rear mounting bracket. Use the bolt pattern that fits closest to the frame. Loosely mount with Grade 5 nyloc nut (not provided), repeat for bottom bolt/washer/nut.
3. Using the spare tire to determine the correct holes* to use, place the carriage bolts provided for mounting the spare tire in the holes of the tire mounting plate. Bolt heads should be on the back side of the tire carrier. Secure bolts with retainers.
4. Check position of the tire mount for proper clearance with the spare tire before tightening bolts.
5. Once position is determined tighten both mounting bolts/nuts.
6. Mount spare tire and tighten lug nuts.

* NOTE:

Wheel mounting is spaced to utilize three bolts on an 8 hole rim and two bolts on a 6 hole rim.

