



best in the
LongRun

High Mount Spare Tire Carrier

Installation Instructions Part #86101

This kit contains the following components:

#	Qty.	Part #	Description
1	1	48052	Spare Tire Carrier
2	1	48053	Tire Carrier Mounting Plate
3	1	10645	Nyloc Nut 1/2"
4	1	10019	Washer 1/2"
5	2	10017	Washers 3/8"
6	2	10863	Carriage Bolt 1/2" 20 x 1-3/4"
7	1	10951	Hex Head Bolt 1/2" x 6-1/2"
8	1	83360-1Z	Ubolt 3/8"x 1.88"x 6"
9	2	10640	Bolt Retainer
10	2	10627	Nyloc Nut 3/8"
11	2	10641	Lug Nut 1/2" - 20

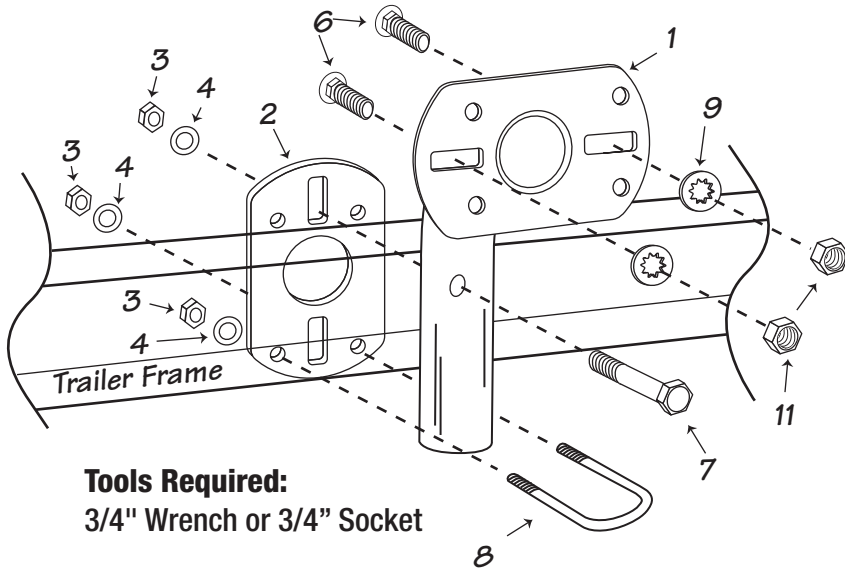

Tools Required:

3/4" Wrench or 3/4" Socket

- Using the spare tire carrier and spare tire as a guide, determine a suitable mounting location on trailer frame.
- Push the 1/2"x 6" bolt through the tube and position on top of the trailer frame.
- Place the mounting plate against the inside of the frame with the 1/2" bolt going through the top oval hole.
- The mounting plate will accommodate several size frames by using the various hole patterns. The mounting plate can even be rotated 180° to provide a tight fit.
NOTE: see diagram for 2x3 and 3x4 frame tubes.
- Slide U-bolt around the tire carrier tube below the frame and through the bottom holes in the mounting tube.
- Check position of the tire mount for proper clearance with the spare tire before tightening bolts.
- Mount spare tire with 1/2" bolts, washers and lug nuts provided.
- Place the carriage bolts provided for mounting the spare tire in the rectangular holes on the mounting plate. Bolt heads should be on the back side of the tire carrier. Secure bolts with "star" washers.

Rear Mounting Plate Top

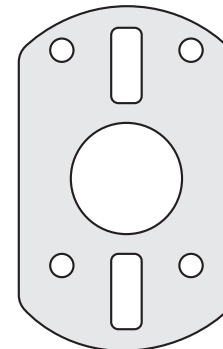

Position for
2"w x 3"h Tubes

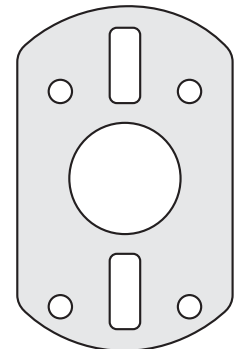

Position for
3"w x 4"h Tubes

Instruction Sheet #08073



AB04: 051116