

Diverter Valve

Diverter Valve

Allows one pump to draw from two locations

- Robust, reliable design
- Teflon® lubricated non-stick operation
- Precision machined for odour-proof seal
- Withstands sewage/black waste, saltwater and bilgewater
- Models available in either 25 mm (1") or 38 mm (1 1/2") hose connection

Typical Uses

- Suitable for electric or manual waste management systems
- Used in bilge and toilet waste systems
- Diverts flow to holding tank or overboard or deck pump out



Diverter Valve
5 Year Warranty

Model Specifications

Model	Diverter Valve	Diverter Valve
Product Code	DV5630	DV5606
Hose Connections	25 mm (1")	38 mm (1 1/2")
Materials	Main Body: Acetal, Teflon®, Handle: PTFE Polyester	

Allows one pump to draw from two locations

Note: These specifications are retail items only.

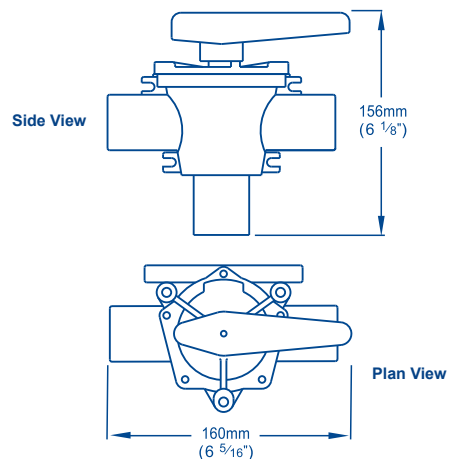

Bilge Strainers/Strum Boxes

3/4" Strainer

3/4" (19mm) Strainer with Multi-Directional Port and Non-Return Valve



SB3422
(Top/Side entry)

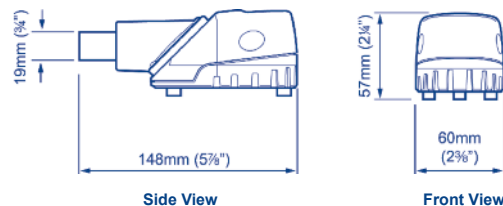

1" / 1 1/2" Strainer

1" (25mm) / 1 1/2" (38mm) Strainers available with top or side entry

Model	Top Entry Strainer	Side Entry Strainer
Product Code	SB5865	SB4222
Materials	Polypropylene	



SB4222 SB5865

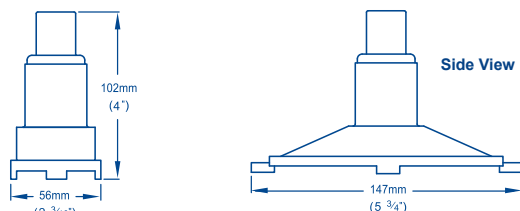

SB5865

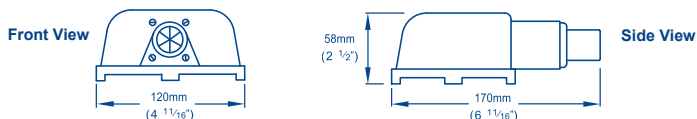

SB4222

Looking for dependable boat plumbing? Rely on Whale for quality and long-lasting products.