



INSTALLATION AND OPERATION MANUAL

Whale® Bilge IC Waste Pump Range



Model Number	Description
BP2082B	Gulper IC - 12 V d.c.
BP2084B	Gulper IC - 24 V d.c.
SI8284	Retail Bilge IC - Remote Mounted Bilge Kit 12 V d.c.
SI8484	Retail Bilge IC - Remote Mounted Bilge Kit 24 V d.c.
SI8222B	Bulk Strainer IC and Gulper IC - 12 V d.c with 2m (6ft) cable
SI8224B	Bulk Strainer IC and Gulper IC - 12 V d.c with 4m (12ft) cable
SI8422B	Bulk Strainer IC and Gulper IC - 24 V d.c with 2m (6ft) cable
SI8424B	Bulk Strainer IC and Gulper IC - 24 V d.c with 4m (12ft) cable

Model Number	Description
BP2082B	Gulper IC - 12 V d.c.
BP2084B	Gulper IC - 24 V d.c.
SI8284	Retail Bilge IC - Remote Mounted Bilge Kit 12 V d.c.
SI8484	Retail Bilge IC - Remote Mounted Bilge Kit 24 V d.c.
SI8222B	Bulk Strainer IC and Gulper® IC - 12 V d.c with 2m (6ft) cable
SI8224B	Bulk Strainer IC and Gulper® IC - 12 V d.c with 4m (12ft) cable
SI8422B	Bulk Strainer IC and Gulper® IC - 24 V d.c with 2m (6ft) cable
SI8424B	Bulk Strainer IC and Gulper® IC - 24 V d.c with 4m (12ft) cable

INSTALLATION & USER INSTRUCTIONS

Thank you for purchasing this Whale® product. For over 70 years, Whale® has led the way in the design and manufacture of freshwater and waste systems including: pumps, plumbing, faucets and showers for low voltage applications. The company and its products have built a reputation for quality, reliability and innovation backed up by excellent customer service.

1. TYPICAL INSTALLATION

This Gulper® IC is a high capacity waste pump with intelligent control electronics inside designed to be installed in recreational marine vessels as a remote mounted bilge pump - Suitable as a primary bilge pump for boats up to 12 metres / 39.4 ft (designed to ISO15083), or as a secondary bilge pump on any vessel.

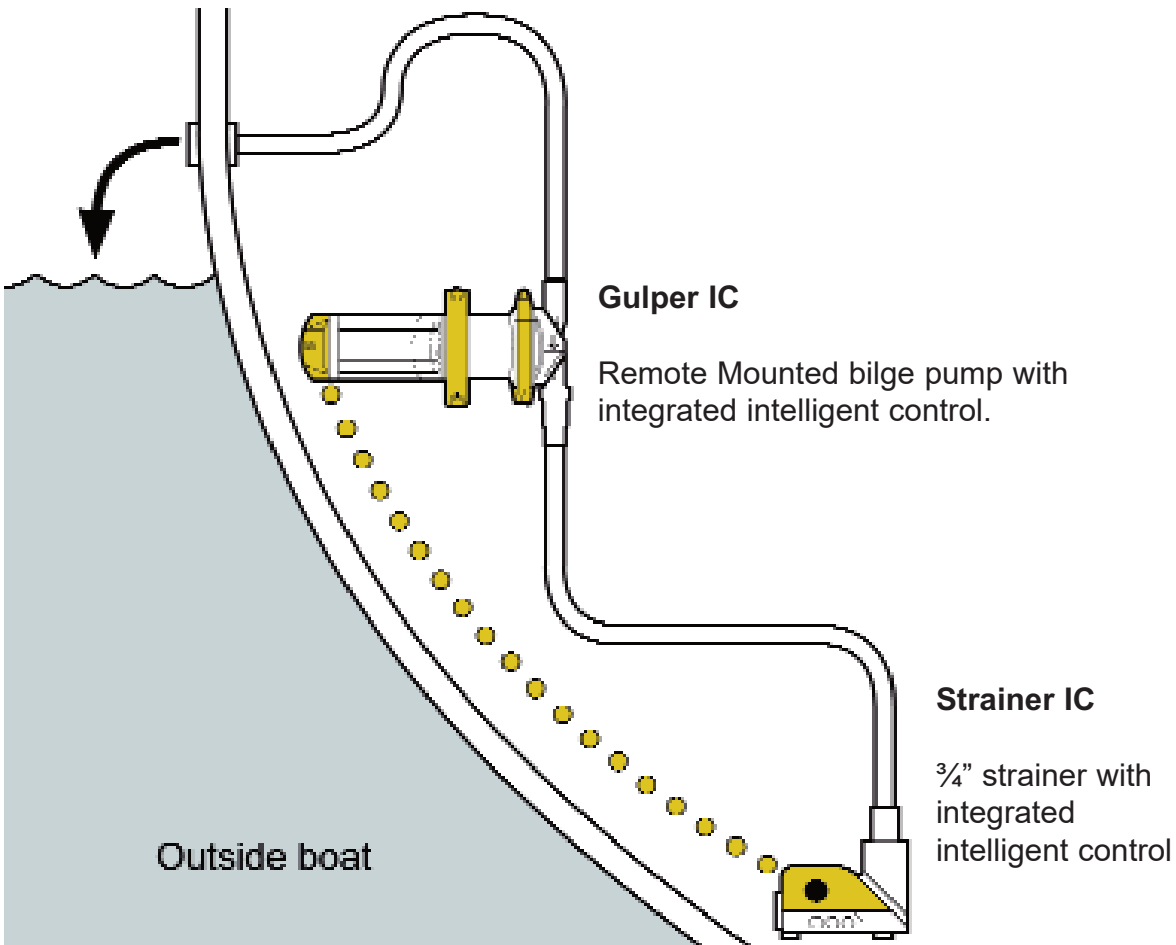

Fig 1. Typical Installation Gulper® IC as a Remote Mounted Bilge Pump

2. SPECIFICATION

Model	Bilge IC Bilge Water Kit							
Product Code	BP2082B	SI8284	SI8222B	SI8224B	BP2084B	SI8484	SI8422B	SI8424B
Cable Length	/	4m (12ft)	2m (6ft)	4m (12ft)	/	4m (12ft)	2m (6ft)	4m (12ft)
Voltage	12V d.c.				24V d.c.			
Voltage Range	10 v d.c. to 13.6 V d.c.				21.6 V d.c. to 27.2 V d.c.			
Current Profile	Soft start / soft stop							
Recommended Fuse Size	10 Amp Automotive				5 Amp Automotive			
Minimum Wire Size	1.5mm ² (16 AWG)							
Weight	2.6 kg (5.7 lbs)							
Materials	Pump head - Glass filled Nylon. Valves and Diaphragm - Santoprene® Pump Body - Aluminium. Gear Wheel - Delrin® Fasteners - Stainless Steel							
Service Kits / Accessories	AK2050 - Replacement Gulper® Pump Head AK2086B - Deutsch Connector Extension Cable 6m (18ft)							
Hose Connections	Gulper® IC - Barbed connections - either 19mm (¾") or 25mm (1") Strainer IC - 19mm (¾") port							
Port Orientation for Strainer IC	Horizontal (easily changed to vertical / side)							
Maximum Suction Lift (Vertical)	3m (10 ft)							
Maximum Discharge Head (Vertical)	3m (10 ft)							
Maximum Discharge Head and Suction Lift Combined (vertical vent)	4m (13.5 ft)							
Operational Time Delays	1 second on delay / 45 second off delay							
Current Draw On Standby	Low power 0.01 Amps supply							

PERFORMANCE DATA

Suction Lift	0m / 0ft	0m / 0ft	1m / 3ft	1m / 3ft
Discharge Head	1m / 3ft	1m / 3ft	1m / 3ft	1m / 3ft
Hose Size	19mm / ¾"	25mm / 1"	19mm / ¾"	25mm / 1"
Flow Rate per min	19 ltrs (5 US gals)	17.5 ltrs (4.6 US gals)	17.5 ltrs (4.6 US gals)	15.5 ltrs (4.1 US gals)
Flow Rate per hour	1140 ltrs (300 US gals)	1050 ltrs (276 US gals)	1038 ltrs (270 US gals)	930 Ltrs (246 US gals)
Current Draw (12 V d.c.)	7.5 amps	8 amps	7.5 amps	8 amps
Current Draw (24 V d.c.)	3.25 amps	4 amps	3.25 amps	4 amps

Note - Output capacity depends on installation and operating conditions.

Whale's policy is one of continuous improvement and we reserve the right to change specifications without prior notice.

3. LIST OF CONTENTS AND LIST OF DIAGRAMS

1.	TYPICAL INSTALLATION	12.	PLUMBING
2.	SPECIFICATION	13.	INSTRUCTIONS FOR USE
3.	CONTENTS AND DIAGRAMS	14.	MAINTENANCE
4.	PRINCIPLES OF OPERATION	15.	HELPFUL HINTS
5.	TO THE USER	16.	TROUBLE SHOOTING
6.	TO THE FITTER	17.	WINTERIZING
7.	APPLICATION	18.	SERVICE SUPPORT DETAILS
8.	WARNINGS	19.	PATENTS/ TRADEMARKS
9.	PARTS LIST	20.	WARRANTY STATEMENT
10.	OPTIONAL EXTRAS	21.	EU DECLARATION OF CONFORMITY, APPROVALS
11.	INSTALLATION		

LIST OF DIAGRAMS:

Fig 1	Gulper® IC - Typical Installation - Remote Mounting Bilge Pump For Use With Whale Strainer IC
Fig 2	Pump Orientation
Fig 3	Gulper® IC Installation
Fig 4	Install P Clamp
Fig 5	Strainer IC Connection
Fig 6	Strainer IC Connection
Fig 7	Wiring Gulper® IC To Strainer IC
Fig 8	Connecting Switching Cable Through Bulkhead
Fig 9	Connect Deutsch® Connectors
Fig 10	Securing Pipework
Fig 11	Strainer IC Operation Test
Fig 12	For Cleaning - Detach Top Cover Of Strainer IC
Fig 13	For Cleaning - Unscrew Valve Housing

4. PRINCIPALS OF OPERATION

IC - Intelligent Control Technology

At the heart of every Whale® IC product lies innovative electronic control circuitry built in. This enables IC sensor accessories to communicate directly with IC pumps to control their performance. These accessories send signals to built-in intelligent software which then control the pumps to react as required.

Gulper® IC

The Gulper® IC fully automatic self-priming pump is designed as a remote mounting bilge pump. Output capacity depends on installation and operating conditions.

Remote Mounted Bilge Application

Save time and money by reducing four separate components to one pre-wired system. Remote mounting automatic Gulper® IC receives signals from Strainer IC and switches on and off automatically (See Fig 1). Suitable for a primary bilge pump for boats smaller than 12 metres/39.4 ft (designed to ISO15083), or as a secondary bilge pump on any recreational marine vessel.

5. TO THE USER

Read the following instructions carefully.

6. TO THE FITTER

Check that the product is suitable for the intended application, follow these installation instructions and ensure all relevant personnel read the points listed below. Also ensure that these operating instructions are passed on to the end user.

7. APPLICATION

Gulper® IC is designed for installation in recreational marine vessels only and operated on 12 or 24 V d.c. electrical supply only. If it is intended for use for any other purpose or with any other liquid, it is the user's responsibility to ensure that the pump is suitable for the intended use and, in particular, that the materials are fully compatible with the liquids to be used. The Whale Gulper® IC pump is **not** recommended for domestic applications.

8. WARNINGS

- This pump **must not** be mounted below the water line when connected to an intake or outlet unless the system has a vented loop (see Fig 1).
- Not suitable for pumping flammable liquids, diesel, chemicals etc. Suitable for bilge water only.
- **NOTE:** Bilge pump capacities may not be sufficient to prevent flooding from rapid accumulation of water due to storms, rough weather and/ or rapid leaks created by hull damage and or unsafe navigational conditions.
- With all applications, it is important that a system of safe working practice is applied to installation, use and maintenance. Ensure the electric supply is turned off and waste water system is drained before installation. In order to securely fasten the unit, ensure that the mounting surface is a minimum thickness of 19mm ($\frac{3}{4}$ ") (when fitted with the screws supplied).
- **NOTE** Do not screw directly to the hull - must be mounted on a bulkhead or on an additional board.
- **NOTE - DO NOT** unscrew the rear section, as interference with the internal electrics will render the pump unfit for use. - this is a non-serviceable part of the pump.
- **WARNING:** Fire hazard. Wiring must comply with applicable electrical standards and include a properly rated fuse or circuit breaker (See section 11vi.) Improper wiring can cause a fire resulting in injury or death. Switch off the power while making connections. Suggested wiring information is given as a guide only. For full information, refer to the USCG,ABYC and ISO regulations for marine applications and wiring gauges, connectors and fuse protection.



9. PARTS LIST

Qty 1	Gulper® IC bilge pump	Qty 1	Strainer IC
Qty 3	No.8 self tappers and washers	Qty 1	Inline fuse assembly

10. OPTIONAL EXTRAS

AK2050 - Service kit - Replacement head for all Gulper® pumps
AK2086B - Deutsch® Connector Extension Cable 6m (18ft)

11. INSTALLATION

NOTE: Incorrect installation will invalidate warranty.

Preparation - Always disconnect power sources before installing.

11.i Location

- Choose a position to mount the pump that is dry and away from standing water and is free from obstacles.
- Mount in a position with the shortest possible pipe run lengths.

11.ii Mounting Instructions - Gulper® IC

- Gulper® IC can be mounted on a horizontal or vertical surface.

- When mounted vertically ensure that the pump head is below the motor body (see Fig 2).

NOTE - It is recommended that the outlet is mounted above the water line and anti-siphon loops are fitted where applicable - see typical installation (Fig 1).

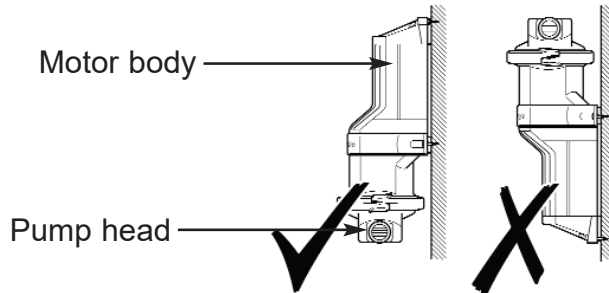

Fig 2. Pump Orientation

- When mounting, position the pump on surface and work out the best angles for the hose (to prevent kinking) and mark the 3 hole positions using the pump feet.
 - **NOTE:** The pump head may be rotated to suit the hose connections. Loosen the screw, adjust and ensure diaphragm remains in place. Reposition the head to the required position (Fig 3) and tighten the screw.
 - Drill pilot holes of 3mm ($\frac{1}{8}$ ").
 - Use the three No.8 self tappers and washers (included) to secure the pump.
- NOTE:** Do not drill through hull, ensure that pump is mounted to additional board or bulkhead.
- Use 19mm ($\frac{3}{4}$ " or 25mm (1") smooth bore reinforced hose to connect to the pump with hose clips.

NOTE: Barbed connections mean no need to cut inlets or outlets to size.

NOTE: Ensure tight connections, but do not over-tighten clamp rings/screws/hose clips.

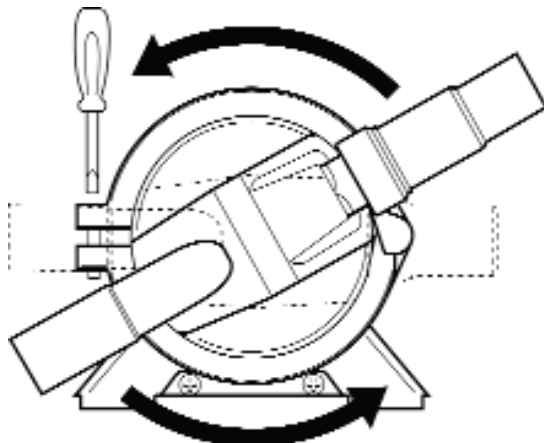

Fig 3. Gulper® Installation

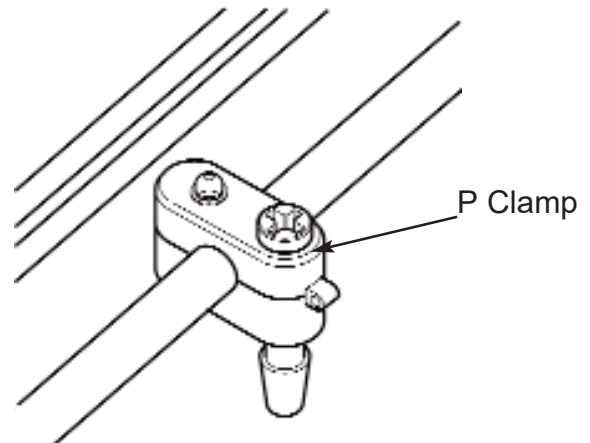

Fig 4. Fit P Clamp

- Screw P clamp to bulkhead ensuring it is located Approx. 100 mm (4") from rear housing (Fig 4).
- NOTE:** In order to securely fasten the unit, ensure that the p clamp mounting surface is at least 19mm ($\frac{3}{4}$ " minimum thickness.

11.iii Mounting Instructions - Strainer IC

- Mount in a position with the shortest pipe run lengths.

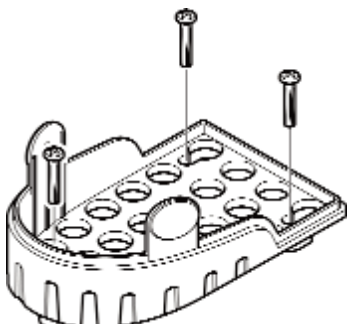

Fig 5. Connect Strainer IC to Bulkhead

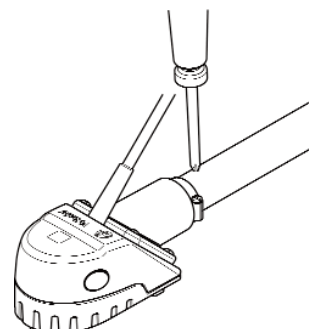

Fig 6. Attaching Jubilee Clips

- Drill pilot holes. **NOTE: do not** drill through hull, ensure that strainer is mounted to additional board or bulkhead (Fig 5).
- Use 19mm (¾") smooth bore reinforced hose to connect to the strainer with hose clips (Fig 6).
- Secure cable by screwing 'P' clamp to bulkhead ensuring it is located approx. 100 mm (4") from strainer outlet (Fig 4).

11.iv Electrical Wiring

- For installation use pre-wired Deutsch® connectors (attached).
- If you are not familiar with applicable electrical standards, ensure that the unit is installed by a qualified electrician/ technician.

WARNING: Fire hazard. Wiring **must comply** with applicable electrical standards and include a properly rated fuse or circuit breaker. Improper wiring can cause a fire resulting in injury or death.

NOTE Switch off the power prior to making connections. Suggested wiring information is given as a guide only. For full information, refer to the USCG, ABYC and ISO regulations for marine applications and wiring gauges, connectors and fuse protection.

Connect Power Cables

The polarity is indicated by coloured cable (Positive = red, Negative = black).

The white wire can be connected to a running light to indicate when the system is in use and / or as a manual override switch.

NOTE The pump is protected against reverse polarity connection (the inline fuse will blow).

NOTE: Undersized wire in the circuit before the pump will reduce voltage when the pump is under load, thus giving poor performance and potential motor failure.

- Ensure all power cables installed are at least the minimum wire size - 1.5mm² (16AWG)
- To control the pump, an isolator switch must be fitted between the positive live terminal on the battery and the positive lead on the pump (See section 11 v).

WARNING Ensure that there are no loops of electrical cable that could be a hazard.

11.v Wiring Diagrams

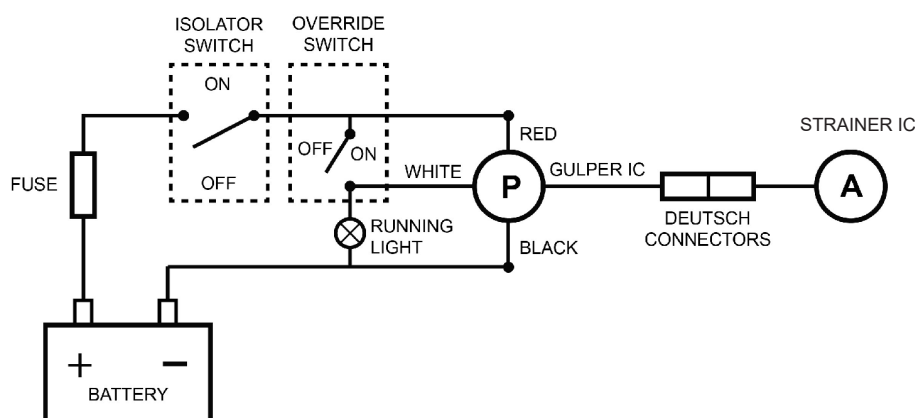

Fig 7. Wiring Gulper® IC to Whale Strainer IC

11.vi. Fitting the Fuse

Fuse rating for BP2082B (12 V d.c.) pumps 10 Amp automotive.

Fuse rating for BP2084B (24 V d.c.) pumps 5 Amp automotive.

The in-line fuse assembly supplied must be fitted to the positive side of the pump (see Fig 7).

Purpose of Fuse: The purpose of this fuse is to protect the pump from serious damage in the event of system blockages, therefore please ensure all valves are fully open before operating the pump.

If the fuse blows:

- a) Check that all system valves/stop cocks are open
- b) Check that the inlet and outlet ports are not blocked
- c) Check that the rest of the system is not blocked
- d) Check for reverse polarity connection

11.vii Connect Switching Cable

If switching cable must be fitted through bulkhead, ensure a minimum hole diameter 25mm (1") is drilled.

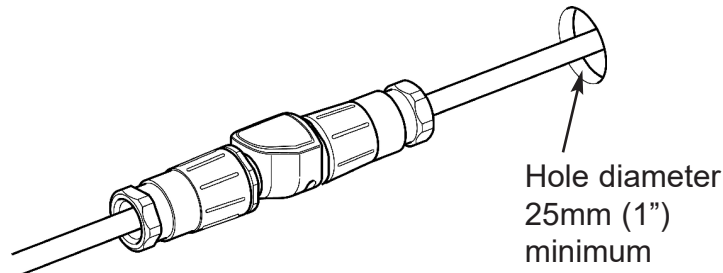

Fig 8. Connecting Switching Cable Through Bulkhead

11.viii Connecting Gulper IC to Strainer IC (See Fig 1)

Connect the pre-wired Deutsch connectors on Gulper® IC and Whale Strainer IC (Fig 9).



Fig 9. Connect Deutsch Connectors

12. PLUMBING

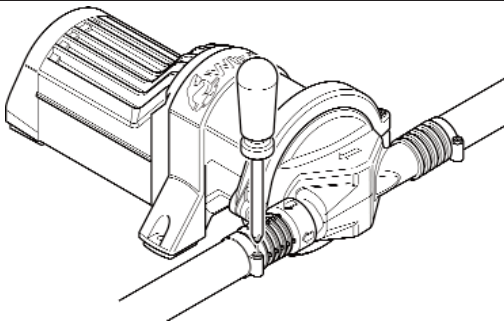

Fig 10. Secure Pipework

Use 19mm ($\frac{3}{4}$ ") or 25mm (1") smooth bore reinforced pipework to connect to the pump.

Secure the pipework on inlet and outlet with worm drive hose clip (Fig 10).

13. INSTRUCTIONS FOR USE

Ensure that pump installation is thoroughly tested before first use.

NOTE - These are all automatic or semi-automatic applications - ensure that isolator switch is turned on.

Bilge application

Gulper® IC with Strainer IC - Place finger over sensor area to check pump is activated, remove finger and wait for the pump to stop (45 seconds).

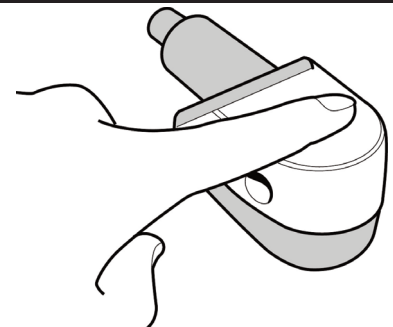

Fig 11. Testing Strainer IC

14. MAINTENANCE

This Whale Gulper® IC is designed to only require minimal maintenance.

WARNING: Before servicing pump, turn off pump and drain water from system.

Annual checks

- Whale advise that the boat's plumbing system is checked annually for leaks and obstructions. Also a pump electrics check is advisable.
- Before inspecting or replacing the diaphragm, disconnect the electrical supply.

Optimal performance

- Ensure this product is clear of debris.

If the pump is not operating as expected:-

- Loosen the hose clips to release the pump from plumbing.
- Unscrew the Ezi-clamp clamping ring to release the pump head (Fig 3). This will release the pump head, and allow easy access to the valves & diaphragm.
- The diaphragm and valves should be checked for any excessive wear, damage or cracks, and should be replaced if necessary (service kit AK2050 - replacement pump head).

Cleaning

Bilge IC should be wiped clean regularly to maintain optimal performance and ensure no clogging occurs. See Fig 12 and Fig 13 for cleaning Strainer IC. **WARNING:** Do not use abrasive cleaners.

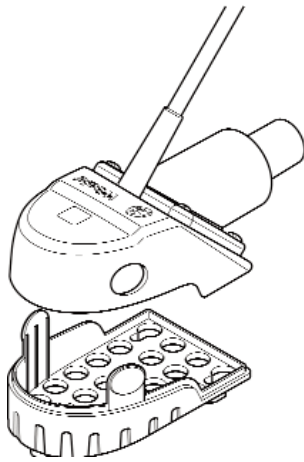

Fig 12. For Cleaning - Detach Top Cover of Strainer IC

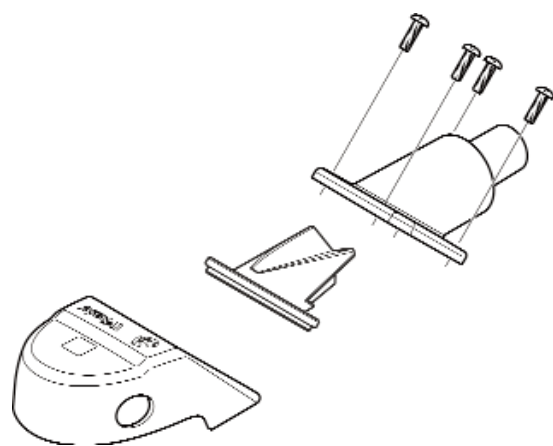

Fig 13. For Cleaning - Unscrew Valve Housing

15. HELPFUL HINTS

The unique ezi-clamp ring makes installation and maintenance of the pump easier with a retaining screw which means the head can be fitted or replaced easily by one fitter, without the risk of dropping screws.

16. TROUBLESHOOTING

WARNING: DO NOT unscrew the rear section as interference with the internal electrics will render the pump unfit for use - this is a non-serviceable part of the pump.

PROBLEM	POSSIBLE CAUSES	POTENTIAL SOLUTION
Gulper IC fails to operate	The Strainer IC may need cleaned. Blockage in valve housing	Unclip the top cover of the Strainer IC, clean and inspect for debris (Fig 12). Carefully remove the lid and clean the inside walls, if necessary unscrew the valve housing assembly for further cleaning.
	Isolator switch not working / not switched on. Pump circuit has no power	Check the isolator switch is on and working. Check electrical connections to ensure pump is receiving power as normal and free from corrosion. Check power supply.
	Main power (Isolator switch) supply OFF /not working. Loose wiring connection	Check the isolator switch is on.
	Pump circuit has no power	Check electrical connections to ensure pump is receiving power as normal and free from corrosion. Check there is 12/24 volts from the battery.
	Fuse blown or loose electrical connection	Check the in-line fuse & ensure all electrical connections are tight and free from corrosion. If fuse has blown, check for reverse polarity, closed valves or seacocks, then for debris in pump head and clean out if necessary (refer to installation section). Replace fuse and run pump.
Failure to prime - Motor operates, but no pump discharge	Debris under flap valves / not seated properly	Turn off electrics and disconnect plumbing check valves for blockages and remove debris (See section 14).
	Air leak in intake line	Check hose connections are airtight. Open pump head and check valves and diaphragm (see section 14).
	Punctured pump diaphragm	Replace the damaged part using service kit - Part number AK2050.
	Restricted intake or discharge line	Check all hose connections are airtight, free from blockages, and hose has not collapsed/kinked.
Pump fails to turn off when required	Strainer IC bilge strainer, not working	Check Strainer IC is operating properly (see section 13).
	Defective/ debris on grey waste float switch	Clear debris/ replace float switch.
	Insufficient voltage to the pump	Check power supply to pump.
	Override switch activated	Turn off override switch.
Low flow	Air leak at pump intake	Check the hose connections are airtight.
	Debris inside pump and plumbing	Turn off electrics and disconnect plumbing, check for blockages and remove (See section 14).
	Punctured pump diaphragm	Replace the damaged part using service kit - Part number AK2050.
	Defective electronic control	Replace pump. If within specified warranty period contact Whale (see contact details).

17. WINTERIZING

NOTE: Winterizing - Fully drain system.

Whale® cannot guarantee warranty if the system is not fully drained for winterizing.

19. PATENTS AND TRADEMARKS

Whale® and Gulper® are registered trademarks to Munster Simms Engineering Limited (also trading as Whale). Whale® Gulper® IC products are protected by the following patent applications:

P92580GB00

P92043GB00

DEUTSCH® is a registered trade name of Deutsch Group. Santoprene® is a registered trade name of Advanced Elastomer Systems, LP, an Exxonmobil Chemical Affiliate Delrin®, Teflon® and Neoprene are registered trade names of Dupont Neumeurs and Co. Monprene® is a registered trade name of Technore Apex.

21. DECLARATION OF CONFORMITY, STANDARDS, APPROVALS

This product complies with all relevant European directives and standards. Please contact Whale® if further details are required.

EU Declaration no.: EU-MSE005-001

Technical file number: TF-MSE005-001

We the undersigned:

Name of manufacturer:

Munster Simms Engineering Ltd

Declare under our sole responsibility that the following apparatus:

Product description:	Gulper Intelligent Control (IC) Kits and accessories	
Model name and no.:	Bilge IC Pump Kits:	SI82XX, SI84XX
	Grey Waste Pump Kits:	SG8XXX, WM8XXX
	IC Accessories:	SI25XX, SI34XX, SG19XX, SG34XX, WM19XX, WM25XX, WM38XX

Brand name: Whale

Is/Are in conformity with the following relevant EU Legislation:

2013/53/EU	Recreational Craft Directive
2014/30/EU	EMC Directive
2011/65/EU	RoHS II Directive

Based on the following harmonized standards:

EN 55014-1:2006 + A2:2011	EMC Emissions
EN 55014-2:1997+ A2:2008	EMC Immunity
EN 28846:1993 + A1:2000	Ignition Protection
EN ISO 8849:2003	Electrically Operated Bilge Pumps
EN ISO 15083: 2003	Small Craft - Bilge Pumping Systems

And the following non-harmonized standards:

And therefore complies with the essential requirements of those directives.

Additional information:

Where applicable this product also conforms to the following standards:

ABYC H-22, 2011	DC Electric Bilge Pumps operating under 50 volts
-----------------	--

Name and position of person binding the manufacturer or authorized representative:

Name:	Richard Bovill
Function:	Engineering Director
Location:	Munster Simms Engineering Ltd,
Date of Issue:	