



**Whale Compac 50  
BP0350**





## Whale Compac 50 BP0350

Thank you for purchasing this Whale® product. For over 60 years, Whale has led the way in the design and manufacture of freshwater and waste systems including: pumps, plumbing faucets, showers for low voltage applications.

### 1. SPECIFICATION

Model Number	BP0350
Weight	0.9 kg (2 lbs)
Hose Connections	25 mm (1") Smooth Hose Connections
Materials	Pump Body: Glass-filled Polypropylene, Clamp Ring: Acetal, Diaphragm, Valves and Seals: Nitrile®, Operating Lever: Glass-filled Nylon, Gaiter: EPDM, Deck Plate Cover: PBT, Fasteners: Stainless Steel
Materials in contact with fluid	Glass-filled Polypropylene, Nitrile®, Stainless Steel
Maximum Suction Lift	3 m (10 ft)
Maximum Discharge Head	4 m (13.5 ft)

### 2. TO THE USER

Read the following carefully before installation. **WARNING:** Please note that incorrect installation may invalidate the warranty.

### 3. TO THE INSTALLER

Check that the product is suitable for the intended application, follow these installation instructions and ensure all relevant personnel read the points listed below. Also ensure that these operating instructions are passed on to the end user.

### 4. APPLICATION

This Compac 50 is designed for installation in recreational marine vessels only as a manual bilge pump. If it is intended for any other purpose or with any other liquid, it is the user's responsibility to ensure that the pump is suitable for the intended use and, in particular, that the materials are fully compatible with the liquids to be used. The Whale Compac 50 is **not** recommended for domestic applications.

### 5. WARNINGS

1. With all applications, it is important that a system of safe working practice is applied to installation, use and maintenance. The electric supply **must be** turned off and water system drained prior to installation.
2. **Not suitable** for pumping flammable liquids, diesel, chemicals etc. Suitable for bilge water only.
3. **NOTE:** Bilge pump capacities may not be sufficient to prevent flooding from rapid accumulation of water due to storms, rough weather and/ or rapid leaks created by hull damage and or unsafe navigational conditions.
4. In order to securely fasten the unit, ensure that the mounting surface is a minimum thickness of 5mm (3/16") (when fitted with the screws supplied). **NOTE Do not** screw directly to the hull - must be mounted on a bulkhead or on an additional board.

**Note:** Incorrect installation will invalidate warranty.

#### 6.i Location

- Choose a position to mount the pump that is dry and away from standing water and is free from obstacles.
- To maximize performance, mount in a position with the shortest possible pipe run lengths.

#### 6.ii Installation

The Compac 50 is a covered diaphragm pump, designed specifically for low profile installation below deck or thru bulkhead. The pump chamber complete with inlet/outlet hose connections, can be rotated through 360° (Fig. 1) allowing complete flexibility in the choice of flow direction relative to the handle position.

**To change direction of pump flow:** Slacken the clamping ring screws and rotate the pump body to the desired positions. Re-tighten the clamping screws, (this can be adjusted even after installation).

**Inlet/Outlet Options:** There are 4 possible hose directions for both inlet and outlet. These can be combined to give 16 port orientations (see Fig 2).

**To Change Inlet/Outlet Positions:** Remove the 4 self-tapping screws from base of inlet/outlet. Reposition the inlet/outlet, replace the 4 self-tapping screws and tighten.

#### Mounting the Pump

The Whale Compac 50 is provided with a deckplate. The hole positions are square, allowing a choice of pump stroke direction, relative to the orientation of the deckplate.

1. Using the deckplate as template, mark off and drill 4 x 1/4" (6 mm) holes and cut out a 3 3/8" (86 mm) hole, which should be central to the 4 x 1/4" (6 mm) holes. Round off the edge of the hole to allow easy mounting of the rubber gaiter.
2. Minimum deck thickness is 3/16" (5 mm). Deck can be reinforced up to a maximum of 5/8" (15 mm) by using a backing plate.

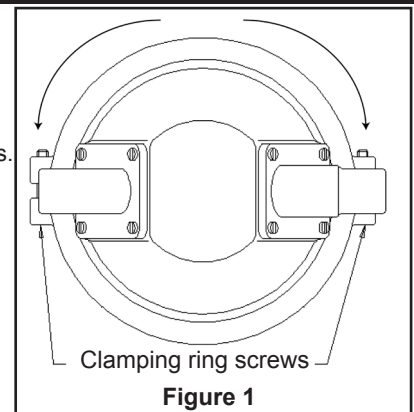

Figure 1

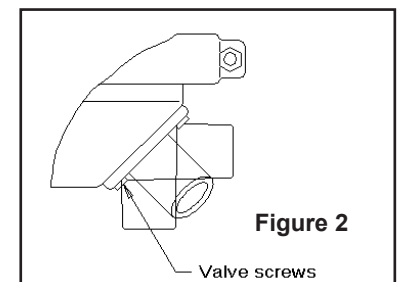

Figure 2

3. Position the pump underdeck and check flow direction.
4. Work the rubber gaiter up through the hole until its flange rests on the deck.
5. Place deck plate cover on top of the deck and secure with the 4 screws provided into the pump body.
6. Attach 1" I.D. (25 mm) smooth bore reinforced hose with stainless steel wormdrive hose clips. Tighten the clips to prevent air leaks.
7. With thru-hull discharge, make sure that the discharge point is above the water line.
8. Check the installation for air leaks, correct priming and discharge.

## 7. INSTRUCTIONS FOR USE

The Whale Compac 50 ensures efficient throughput with an easy pumping action. Full even strokes will obtain the best results. Two clips are provided for storing the handle when the pump is not in use.

Output	At 45 Strokes/Min	At 70 Strokes/Min
US Gal/min	9	9.2
Litres/min	32	35

**Please note:** Performance data is based on factory tests and is typical of what may reasonably be achieved. Actual performance may vary depending on installation and operating conditions.

## 8. MAINTENANCE

This Whale® Compac 50 is designed to only require minimal maintenance.

**WARNING:** Before servicing, turn off the power and drain water from system.

### Optimal Performance

- For optimal performance, regular inspection of the pump for debris and damage is recommended.
- Rubber components are perishable and susceptible to damage. They should be inspected periodically and replaced as necessary

### Changing the Diaphragm and Valves

#### Diaphragm:

1. Slacken and remove the clamping ring screws and remove clamping rings (hoses may be left attached).
2. Remove clamping plate screw and clamping plate.
3. Replace diaphragm ensuring the centre portion of the diaphragm projects into valve chamber.
4. Check diaphragm is "seated" in the cover grooves.

#### Valves:

1. Unscrew the 4 self tapping screws at the base of the inlet/outlet nipples (hoses can be left attached).
2. Remove and replace the valves ensuring that they are correctly seated in the pump body groove.
3. Replace the nipples in their mounting position and secure in place.

## 9. TROUBLESHOOTING

Pump fails to prime or chokes:

- Check inlet hose connection is airtight and does not collapse during the suction stroke.
- Inspect inlet and outlet valves for blockages. Clear with finger or screwdriver and test.
- Solid objects in the body of the pump should not prevent operation but **must** be removed to prevent damage.

## 10. WINTERIZING

**NOTE** When winterizing, fully drain system.

Whale® does not cover damage, caused by the system not being not fully drained for winterizing.