

1. To the Fitter

Ensure all relevant personnel read the points listed below and that a copy is passed on to the end user.

2. To the User

Read the points listed below before installation and use of equipment.

3. Application

The Gulper 220 self-priming pump has been specifically designed to pump waste water from the shower tray / galley sink, (either overboard or into a holding tank) or as a small bilge pump. Output capacity depends on installation and operating conditions.

Note: When used as a bilge pump users should be aware that capacity may not be sufficient to cope with rapid influx of water. If it is intended for use for any other purpose or with any other liquid, it is the user's responsibility to ensure that the pump is suitable for the intended use and, in particular, that the materials are fully compatible with the liquids to be used. With all applications it is important that a system of safe working practice is applied to installation, use and maintenance.

4. Installation

Choose a position to mount the pump that is dry and away from casual water. The pump may be mounted on a horizontal or vertical surface. When mounted vertically ensure that the pump head is lower most (see diagram below)

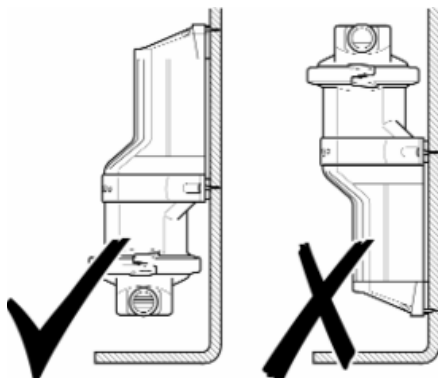

When mounting, position the pump on the intended surface and work-out the best angles for the hose, then mark the 4 hole positions using the pump feet. The pump head may be rotated to suit the hose connections, this is done by loosening the two screws that hold the clamping

rings, and rotating the pump head. Once you have marked the position for the four mounting feet, drill four pilot holes of 3.2mm (1/8"). Use the four No.8 self tappers and washers to secure the pump. Use 19mm (3/4") smooth bore reinforced hose to connect to the pump.

5. Electrical Connections

The polarity is indicated by coloured cable (Positive - red, Negative - black). The pump is protected against reverse polarity connection. Minimum wire size is 1.5mm² (16 AWG). (Note: undersized wire reduces voltage under load at the pump, thus giving poor performance and potential motor failure). The in-line fuse assembly supplied (see details below) must be fitted to the positive side of the pump.

In-Line Fuse Assembly

Purpose

The purpose of this fuse is to protect the pump from serious damage in the event of system blockages, therefore please ensure all valves are fully open before operating the pump.

Connection Instructions

Insert this fuse assembly between the positive terminal on the pump and the positive feed wire.

Note:

1. If the fuse blows check:

- a) all system valves/stop cocks are open.
- b) the inlet and outlet nipples are not blocked
- c) the remainder of the system is not blocked in any way.

2. Fuse rating for BP1552 / BP1552B (12v DC) pumps 5 amp automotive. Fuse rating for BP1554 / BP1554B (24v DC) pumps 2.5 amp automotive

To control the pump an in-line switch should be fitted between the positive live terminal on the battery and the positive lead on the pump. If using an automatic switch (such as a float switch) an isolator switch should be fitted.

6. Operation

The Gulper 220 is switched on by either a remote on/off switch or an automatic float switch. When used to drain a shower or galley, the flow rate should be sufficient to take away the waste faster than the delivery from either the shower or galley tap.

7. Maintenance

To inspect or replace either the valves or the diaphragm, disconnect electrical supply the user must firstly remove the pump head clamping rings, this is done by unscrewing the 2 clamping screws.

This will release the pump head, and allow easy access to the valves & diaphragm. The diaphragm and valves should be checked for any excessive wear, damage or cracks, and should be replaced if necessary. If the diaphragm needs to be replaced, undo the nut in the centre of the diaphragm and remove the diaphragm plate & diaphragm. Note: The centre pin may be in one of several positions, this will not affect replacement of the diaphragm). When replacing the diaphragm this can be fitted either cup up or down. Replace clamping plate making sure the rounded edge faces the diaphragm, also ensure that the outer sealing edge of the diaphragm is located securely in the grooves between the body & gear housing (failure to do this will cause the pump NOT to prime). Refit clamping rings and tighten screws.

8. Fault Finding

The electric motor runs but no water is pumped?

Check:

- a) that inlet hose connection is airtight, free from blockages, and does not collapse.
- b) that the shower/sink drain is not clogged.
- c) that the valves in the pump are not blocked & are seating properly in the pump head.
- d) that the diaphragm has not split - replace if damaged.

The motor will not operate?

Check:

- a) the isolator switch is on.
- b) there is 12 volts from the battery.
- c) the in-line fuse & ensure all electrical connections are tight and free from corrosion. (If fuse has blown check for debris in pump head and clean out if necessary replace fuse and run pump - see previous page).