

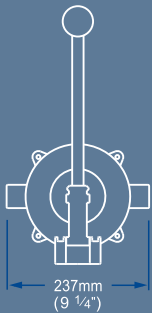

Gusher® Titan
5 Year Warranty

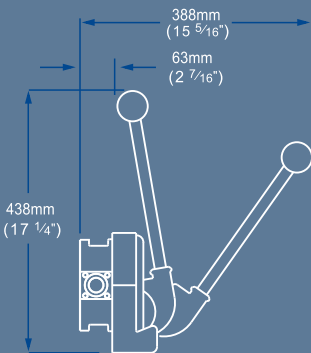

Front View



BP4402
Standard
Side View

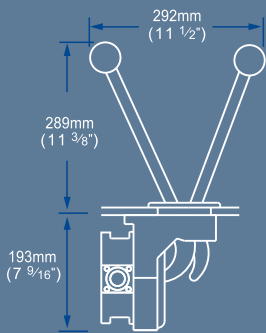

BP4410
Thru Deck/Bulkhead
Side View

Gusher® Titan

Powerful, Lightweight Bilge And Waste Pump

- High flow rate: 105 ltrs (28 US gals) per minute
- Clamp ring easily removed for pump head rotation and quick maintenance
- Tough, lightweight (1.5 kg / 3.3 lbs) proven design
- Bulkhead and thru deck models
- Suitable for use on boats over 12 m (40 ft)

Typical Uses

- Emergency bilge pump out
- Holding tank pump out
- Toilet flush

Model Specifications

Model	On Deck BP4402	Thru Deck / Bulkhead BP4410
Product Code	BP4402	BP4410
Weight	1.5 kg (3.3 lbs)	1.85 kg (4.1 lbs)
Hose Connections	38 mm (1½") Smooth Hose Connections	
Materials	Pump Body: Glass-filled Polypropylene, Clamp Ring: Acetal Diaphragm and Valves: Neoprene, (Nitrile option available) Operating Lever: Glass-filled Nylon, Gaiter: EPDM Fasteners: Stainless Steel	
Materials In Contact With Fluid	Glass-filled Polypropylene, Acetal, Neoprene, Nitrile	
Service Kits	AK4400 - Neoprene Parts AK4419 - Nitrile Parts for Oil and Diesel Contains: Diaphragm, Valves, Seals AS4412 - Clamping Plates Kit AS4406 - Std Lever Kit AS4407 - Std Clamping Ring Kit AS4408 - Underdeck Operating Lever Kit AS3725 - Gaiter Kit for Deckplates	
Accessories	DP8904 - Deck Plate Kit for BP4410 only AS4405 - Spare Handle	
Maximum Suction Lift	4 m (13.5 ft)	
Maximum Discharge Head	4 m (13.5 ft)	

Performance Data

	BP4402 / BP4410	BP4402 / BP4410
Suction Lift	1 m (3 ft)	2 m (6 ft)
Discharge Head	0.5 m (1.5 ft)	0.5 m (1.5 ft)
45 Strokes per Minute	67 ltrs (18 US gals)	65 ltrs (17 US gals)
70 Strokes per Minute	105 ltrs (28 US gals)	98 ltrs (26 US gals)

Skin fitting 38mm (1½")SF5425

