



Gulper® Grouper Fishbox Discharge Pump

Thank you for purchasing this Whale® product. For over 60 years, Whale has led the way in the design and manufacture of freshwater and waste systems including: pumps, plumbing faucets, showers for low voltage applications.

1. Specifications

Model	Gulper Grouper Mk 1 with bronze gearwheel		Gulper Grouper Mk 2 with plastic gearwheel	
Product Code	BP4572	BP4574	BP4672	BP4674
Voltage	12 V d.c.	24 V d.c.	12 V d.c.	24 V d.c.
Flow Rate Per Minute	25.5 ltrs (6.75 US gals)		18 ltrs (4.75 US gals)	
Recommended Fuse Size	10 amp Automotive	5 amp Automotive	10 amp Automotive	5 amp Automotive
Minimum Wire Size	1.5mm ² (16 AWG)			
Weight	1.6kg (3.5 lbs)			
Hose Connections	25mm (1") or 38mm (1½")			
Materials	Pump Body: Aluminium, Glass-filled Nylon, Diaphragm: Santoprene® Clamp Ring: Acetal, Valves: Nitrile®, Feet: EPDM Gearwheel: Bronze, Fasteners: Stainless Steel, Brass		Pump Body: Aluminium, Glass-filled Nylon, Diaphragm: Santoprene® Clamp Ring: Acetal Valves: Nitrile®, Feet: EPDM Gearwheel: Delrin, Fasteners: Stainless Steel, Brass	
Maximum Suction Lift	0.5 m (1.7 ft)		1m (3.3 ft)	
Max Discharge Head	3 m (10 ft)		2m (6.6 ft)	
Max Suction Lift and Discharge Head (Combined)	3 m (10 ft)		3m (10 ft)	
Dry Running Current	5 amps	2.5 amps	4 amps	2 amps

2. To The User

Read the following carefully before installation.

WARNING: Please note that incorrect installation may invalidate the warranty.

3. To The Installer

Check that the product is suitable for the intended application, follow these installation instructions and ensure all relevant personnel read the points listed below. Also ensure that these operating instructions are passed on to the end user.

4. Application

The Gulper® Grouper diaphragm pump has been designed to pump water and small solids from a fish box overboard. If it is intended for use for any other purpose or with any other liquid, it is the user's responsibility to ensure that the pump is suitable for the intended use and, in particular, that the materials are fully compatible with the liquids to be used.

5. Warnings

1. This pump **must not** be mounted below the water line.
2. Not suitable for pumping flammable liquids, diesel, chemicals etc.
3. **NOTE:** Pump capacity is not sufficient to prevent flooding from rapid accumulation of water due to storms, rough weather and/ or rapid leaks created by hull damage and or unsafe navigational conditions.
4. With all applications, it is important that a system of safe working practice is applied to installation, use and maintenance. Electric supply **must be** turned off and waste water system is drained prior to installation.
5. In order to securely fasten the unit, ensure that the mounting surface is a minimum thickness of 19mm (3/4") (when fitted with the screws supplied).
6. **NOTE Do not** screw directly to the hull - the pump **must be** mounted on a bulkhead or on an additional board.
7. **NOTE Do not** unscrew the rear section, as interference with the internal electrics will render the pump unfit for use and invalidate the warranty. This is a non-serviceable part of the pump.
8. **WARNING:** Fire hazard. Wiring must comply with applicable electrical standards and include a properly rated fuse or circuit breaker (see section 7) Improper wiring can cause a fire resulting in injury or death. Switch off the power while making connections.



Suggested wiring information is given as a guide only. For full information, refer to the USCG, ABYC and ISO regulations for marine applications and wiring gauges, connectors and fuse protection.

6. Installation

Note: Incorrect installation will invalidate warranty.

Preparation - Always disconnect power sources before installing.

6.i Location

- Choose a position to mount the pump that is dry and away from standing water.
- The pump may be mounted on a horizontal or vertical surface.
- When mounted vertically ensure that the pump head is lower than the pump body (see Fig 1).

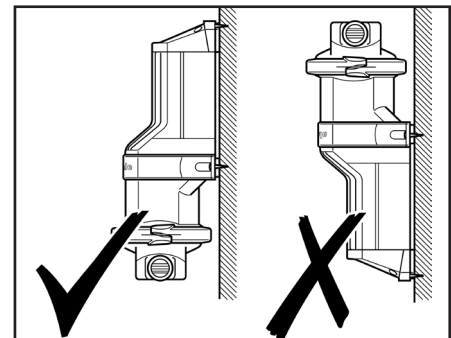

Figure 1 - Pump Orientation

6.ii Mounting Instructions

- The Whale® Gulper® Grouper pump **must be** installed at or below the level of the fish box drain. When mounting, position the pump on the intended surface then mark the 4 hole positions using the pump feet.
- The pump head may be rotated to suit the hose connections; this is achieved by loosening the screw which holds the clamping ring and rotating the pump head (Fig 2).
- Once the position for the four mounting feet is marked, drill four pilot holes of 3.2mm(1/8"). Use four No.8 self-tappers and washers to secure the pump.
- Inspect and ensure that the tricuspid valves are seated on both inlet and outlet ports.

NOTE: Both valves must "point" in the same direction.

- Install ports to the pump head (see Fig 3).
- In retail, 2 x 25mm (1") ports and 2 x 38mm (1 1/2") ports are supplied to suit your installation. For optimum performance, Whale recommend using a 38mm (1 1/2") port on the inlet and 25mm (1") port on the outlet connected with reinforced hose.

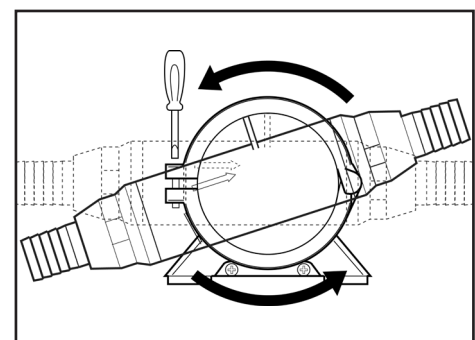

Figure 2 - Rotating Pump Head

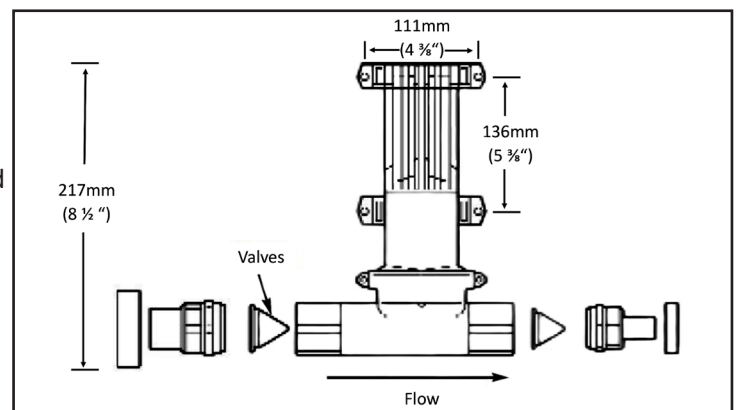

Figure 3 - Gulper Grouper Dimensional Diagram

7. Electrical Connections

NOTE If you are not familiar with applicable electrical standards, ensure that the unit is installed by a qualified electrician / technician.

WARNING: Fire hazard. Wiring must comply with applicable electrical standards and include a properly rated fuse or circuit breaker. Improper wiring can cause a fire resulting in injury or death.

NOTE Switch off the power prior to making connections. Suggested wiring information is given as a guide only. For full information, refer to the USCG, ABYC and ISO regulations for marine applications and wiring gauges, connectors and fuse protection.

- The polarity is indicated by coloured cable (Positive: red, Negative: black). The pump is protected against reverse polarity connection with a diode unless fitted with a Deutsch connector.
- Minimum wire size is to be 1.5mm² or 16 AWG.

NOTE Undersized wire reduces voltage under load at the pump, thus giving poor performance and potential motor failure.

- To control the pump, an in-line switch should be fitted between the positive live terminal on the battery and the positive lead on the pump. If using an automatic switch (such as a float switch) an isolator switch must also be fitted.

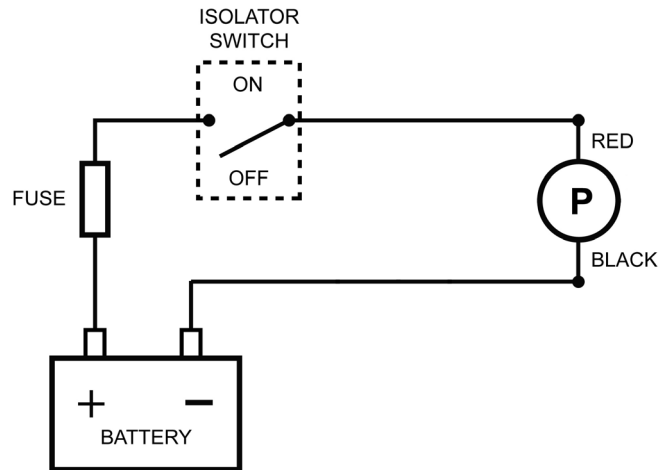

Figure 4 - Wiring

Circuit Breaker / In-Line Fuse Assembly:

The purpose of this fuse is to protect the pump from serious damage in the event of system blockages, therefore please ensure all valves are fully open before operating the pump.

1. If the circuit breaker trips, or the fuse blows, check:
 - a) All system valves / stop cocks are open (if installed).
 - b) The inlet and outlet ports are not blocked.
 - c) The remainder of the system is not blocked in anyway.
2. For 12 V d.c. models, use a 10 Amp automotive fuse. For 24 V d.c. models, use a 5 Amp automotive fuse.

8. Maintenance

This Whale® Gulper® Grouper is designed to only require minimal maintenance.

WARNING: Before servicing pump, turn off pump and drain water from system. Ensure that the pump is disconnected from electrics and plumbing during maintenance.

Optimal Performance

- Ensure this product is clear of debris.
- Flush with water after each use.
- Check wire connections once per season.
- Check / tighten hose clamps on elbow connections once per season.

Annual checks

- Whale advise that the boat's plumbing system is checked annually for leaks and obstructions and a pump electrics check **must be** conducted by a qualified electrician.

To inspect or replace the diaphragm, the user must firstly remove the pump head clamping ring. This is done by unscrewing the clamping screw. This will release the pump head, and allow easy access to the diaphragm.

- If diaphragm shows signs of wear, damage or cracks it should be replaced (using Service Kit AK1557). If the diaphragm needs replaced, undo the nut in the centre of the diaphragm and remove the diaphragm plate and diaphragm.

NOTE The centre pin may be in one of several positions; (this will not affect replacement of the diaphragm).

- When replacing, the diaphragm can be fitted either cup up or down.
- Refit the clamping plate making sure the rounded outside edge faces the diaphragm, also ensure that the outer sealing edge of the diaphragm is located securely in the grooves between the body and gear housing (failure to do this will cause the pump NOT to prime).
- Refit clamping rings and tighten screws.

To inspect or replace the tricuspid valve(s), unscrew either or both housings to expose the valve(s). If a valve shows signs of wear or damage, replace and re-assemble housings ensuring that the valves and diaphragm remain correctly seated.

9. Troubleshooting

Problem	Possible Causes	Solution
Motor runs but pump fails to work	Pump is blocked	Check the hoses, pump head and valves for blockages and clean if necessary
	Tricuspid valves are inverted	Check if the valves are inverted and if so replace the valves
Electric motor does not operate	Isolator switch is not active	Turn the isolator switch on
	Incorrect voltage to the pump	Check the battery is the correct voltage - 12 V or 24 V d.c.
	Fuse has blown	Replace the fuse or reset the circuit breaker

10. Winterizing

NOTE When winterizing, fully drain system.

Whale® does not cover damage, caused by the system not being not fully drained for winterizing.