

Smartbail Manual Bilge Pump



Installation Guidelines for:

Model Number	BP5012	Smartbail with 1" and 1 1/2" port option (retail packed)
Model Number	BP5010B	Smartbail with 1" Ports (bulk packed)
Model Number	BP5021B	Smartbail with 1 1/2" Ports (bulk packed)

Please ensure all relevant personnel read the points listed below before installation of the pump and this is passed on to the end user.

Application

The Whale Smartbail bilge pump is designed to pump standing water when installed through the bulkhead (see fig.1 below). Output capacity depends on installation conditions and pumping rate. **WARNING:** Capacity may not be sufficient to cope with a rapid influx of water.

With all applications it is important that a system of safe working practice is applied to installation, use and maintenance.

If this pump is intended for use for any other purpose outside of the stated guidelines or with any other liquid, it is the user's responsibility to ensure that the pump is suitable for the intended use, and in particular, that the materials are fully compatible with the liquids to be used.

Before Installation

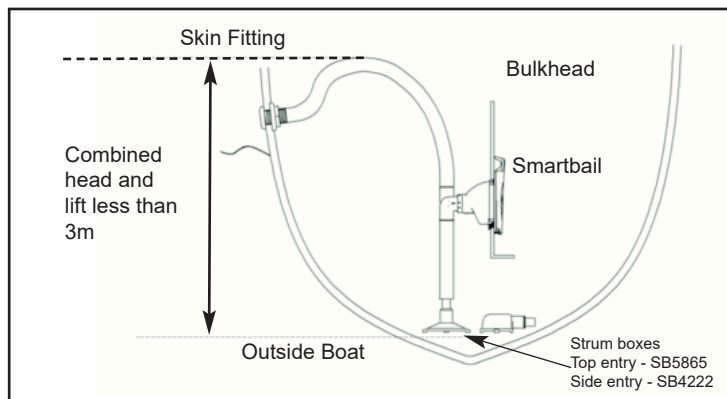

Fig.1 Typical Installation

1. Ensure that there is enough room behind the bulkhead for full depth of the pump when installed. This must include space for inlet and outlet hoses. (See Fig. 2 for maximum dimensions).

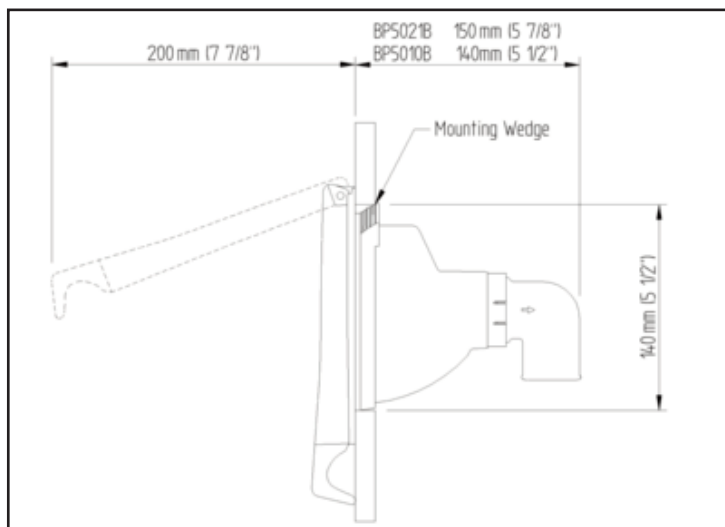

Fig.2 Maximum Dimensions

2. Ensure that enough space is available when the pump is installed in order to operate it with the pump handle fully open. (See fig.3 for recommended mounting positions).

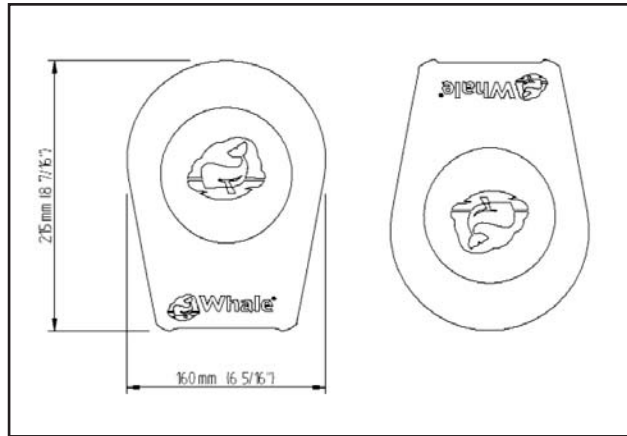

Fig.3 Recommended Mounting Positions

Mounting

1. Select a suitable flat location on the bulkhead and cut out a circular hole diameter 140mm (5½").
2. Place pump through hole and push into position. Either pushing up or down depending on mounting orientation (see fig 4a and b).

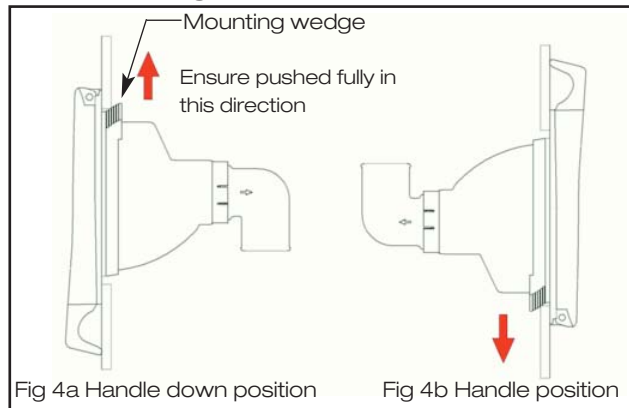

Fig.4 Mounting Pump With Wedge

3. Ensure that the mounting wedge is fully engaged with the bulkhead.
4. Open handle and mark the position of the 4 fixing screw holes on the bulkhead (see fig.5). **Note** – The pump **must be** installed using 4 screws.

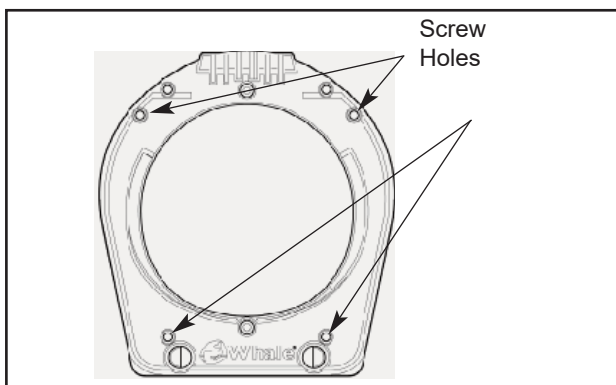

Fig.5 View Of Mounting Positions (Ommiting The Handle)

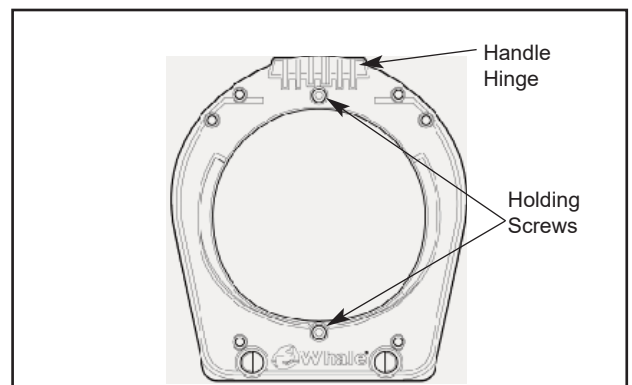

Fig.6

5. Remove pump and drill 4 holes at these marked positions. See table below for recommended screw holes and sizes:

Pilot Drill Hole	Self-tapping Screw
Diameter 3.5 mm	Diameter 5 mm

6. Place pump in position and attach to bulkhead using 4 self tapping screws.

Plumbing

1. Attach inlet/outlet hoses to appropriate elbow at the rear of the pump with stainless steel worm drive clips.

Note:

Both inlet and outlet elbows can be attached to either port. It is very important that the correct valve is installed with the correct port (see fig. 7). See icon on side of each port to confirm the correct valve has been installed with correct port (flat valve on inlet and tricuspid valve on outlet).

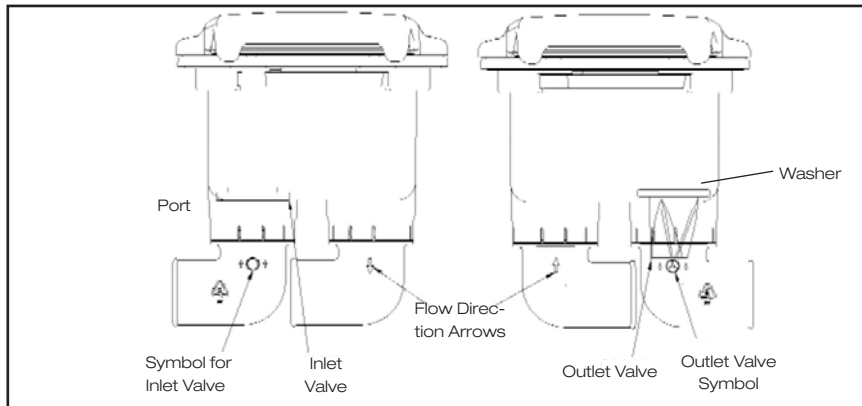

Fig.7 Valves/ Elbow Combination

Symbol	Valve	Flow Direction/ Elbow
	Tricuspid	Outlet Elbow
	Flap	Inlet Elbow

2. It is recommended that the inlet and outlet hoses are restrained a minimum of 300mm (11 3/4") away from the pump to avoid undue stress on the inlet and outlet ports.

For installations where it is necessary to remove elbows before plumbing, the following additional steps are required:

3. The elbows can be removed and hoses attached prior to installation by turning the elbows to a point where the outlet/inlet elbow directly faces the other elbow and then pulling out. See fig. 8 (below).
4. If the elbows have been removed, re-attach simply by pressing the elbow into its correct port until it "clicks" into place.

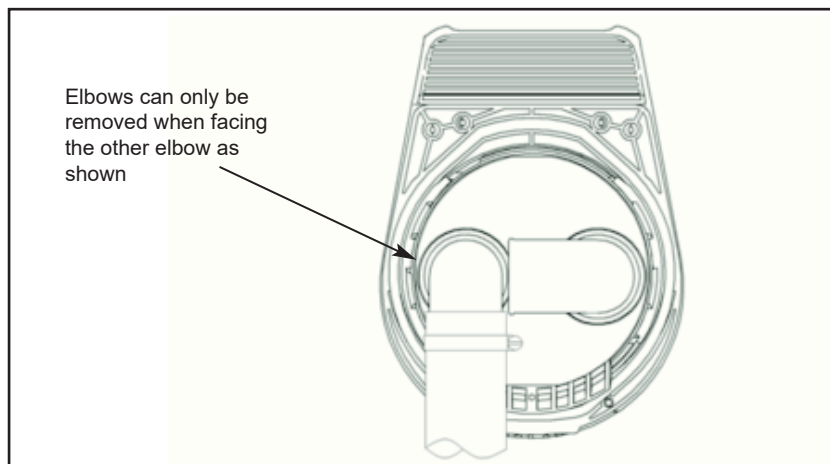

Fig.8 Disconnection Position of Elbows

Technical Specifications

	Whale Smartbail
Product Code	BP5010B, BP5021B
Weight	0.6 kg
Hose Connections	BP5010B - 25 mm ports (1") BP5021B - 38 mm ports (1 1/2")
Materials	Glass-filled Polypropylene, Stainless Steel, Nitrile, Santoprene®
Materials In Contact With Fluid	Pump body: Glass-filled Polypropylene Inlet and outlet valves: Nitrile Diaphragm: Santoprene®
Service Kit	AK5010 - Diaphragm, valves and seals

Performance Data

Maximum Head		3m (9.8ft)			
Maximum Lift (self-priming)		3m (9.8ft)			
Maximum Combined Head and Lift		3m (9.8ft)			
Product Code		BP5010B		BP5021B	
Port Size		25 mm (1")		38 mm (1 1/2")	
Lift	Head	Flow Rate at 45 Strokes/min	Flow Rate at 60 Strokes/min	Flow Rate at 45 Strokes/min	Flow Rate at 60 Strokes/min
0 m (0 ft)	0 m (0 ft)	38.5 ltrs/min 10.2 US gals/min	51.3 ltrs/min 13.6 US gals/min	43.5 ltrs/min 11.5 US gals/min	58 ltrs/min 15.3 US gals/min
0 m (0 ft)	1 m (3 ft)	32.75 ltrs/min 8.7 US gals/min	43.6 ltrs/min 11.5 US gals/min	43.5 ltrs/min 11.5 US gals/min	58 ltrs/min 15.3 US gals/min

Performance data is based on factory test at specified lift and head and is typical of what may reasonably be achieved. Actual performance may vary depending on installation and operating conditions.

Standards Applied: ISO15083

Operation

1. To operate the pump, open the cover by gripping the handle.
2. The pump is then ready for instant operation.
3. After use, push firmly to lock the handle in the closed position.

Maintenance

Regular inspection of the pump is recommended. Rubber components should be replaced if worn or every three years.

Service kit number - AK5010.

Replacing the Diaphragm:

1. Press out hinge pin in illustrated direction using appropriate force (then slide off handle). Care should be taken to keep the retaining washer in a safe place (see fig. 9).
2. Remove pump from bulkhead by removing mounting screws and disconnecting mounting wedge (see fig 5).

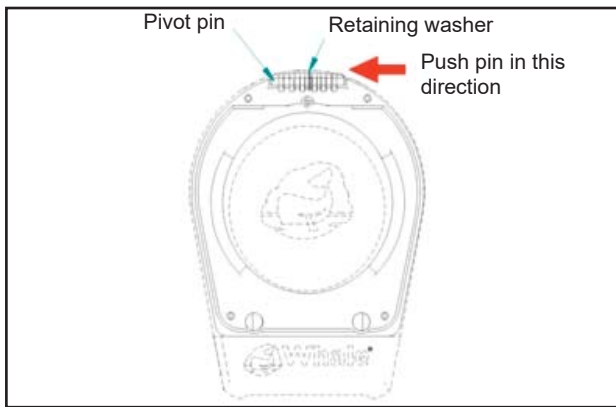

Fig.9

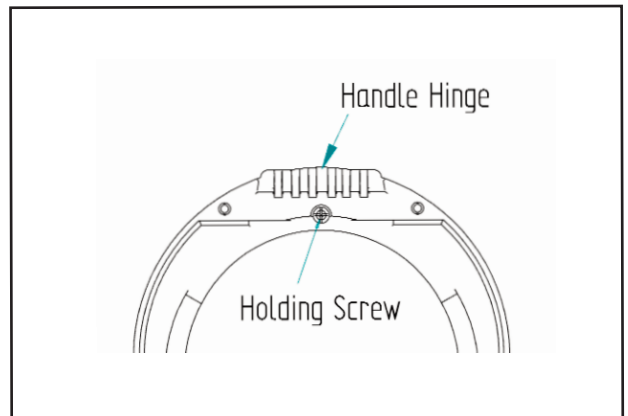

Fig.10

3. Remove holding screws (see fig.10).
4. Rotate the front of the pump anti-clockwise until it reaches a stop (approx. 35 degrees) and lift off front part of the pump body.
5. The diaphragm can now be removed.
6. To install the new diaphragm ensure it is placed in the correct location (See fig.11). A small amount of lubricant e.g. vegetable oil applied to the edge of the diaphragm may ease installation.
7. Once replacement diaphragm is installed, re-attach the front of the pump and rotate clockwise until it reaches a stop (approx. 35 degrees).
8. Re-attach the handle by reconnecting the hinge, pressing the pin through the retaining washer (See fig. 9).
9. Re-mount the pump as per previous mounting instructions.

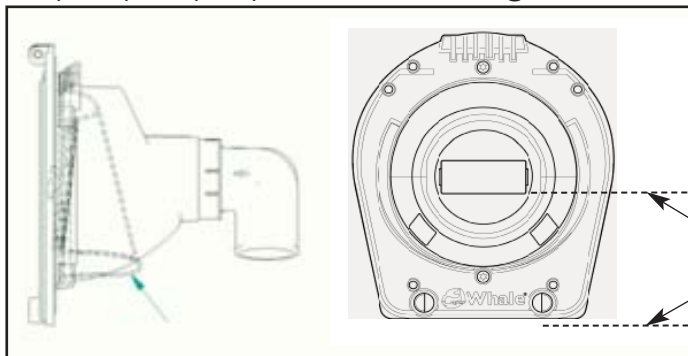

Fig.11

Replacing Valves:

1. Remove pump from bulkhead by unscrewing mounting screws and disconnecting mounting wedge.
2. Disconnect hose from elbows.
3. Remove elbows from ports (see Fig.8).
4. It is very important that the elbows are re-installed with the correct valves inside the correct ports (see fig 7).
5. Ensure the washer on the outlet valve is removed and placed on the replacement valve.
6. To re-install the elbow after replacing the valve, simply press the elbows into the ports till they "click" into place.

Winterisation: To avoid damage as a result of freezing, drain all water in the pipework and pump chamber.