



Automatic Pressure Pump Range

4 chamber design delivers smooth consistent flow.



Anti-vibration feet for reduced noise

FREE

Inlet filter for pump protection

4 chamber pump head ensures smooth constant flow

Powerful performance

- High flow rates at a variety of outlets
- Smooth constant flow
- Self-priming up to 3m (10ft)
- Quiet operation
- Plug 'n' Play easy installation - Suitable For 15mm Quick Connect plumbing or ½" threaded hose connections
- For use with salt or fresh water

Designed for the harsh environment

- Fully sealed protective motor housing - IP65 Rated - No water ingress
- Integrated protected pressure switch
- Runs dry without damage
- Inlet strainer protects pump from debris

Automatic Pressure Pump Range

4 chamber design delivers smooth consistent flow.

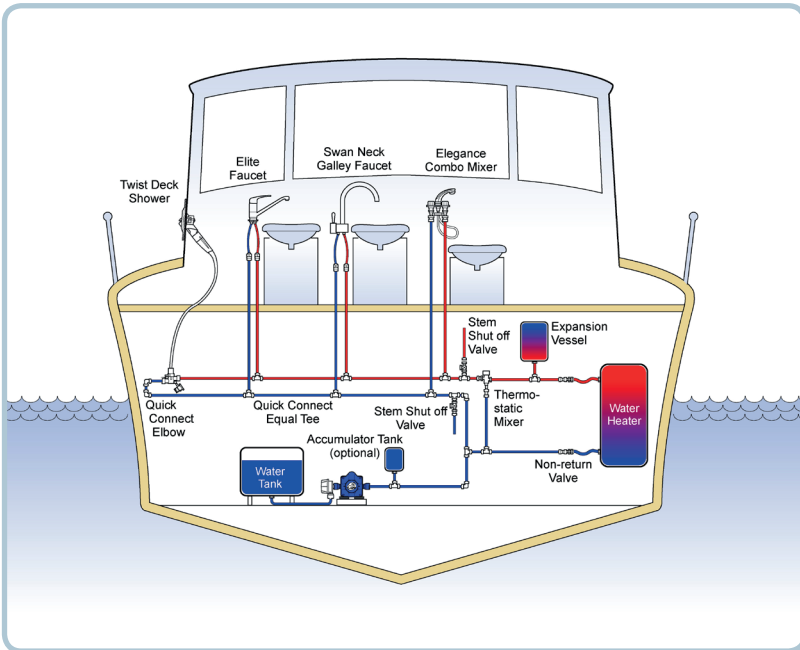

Typical Installation

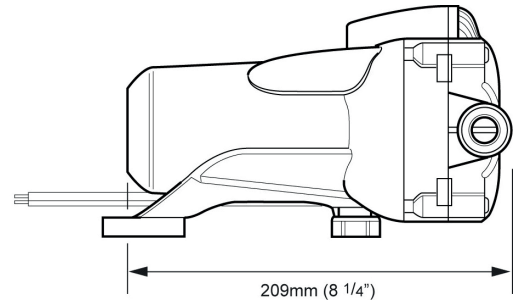
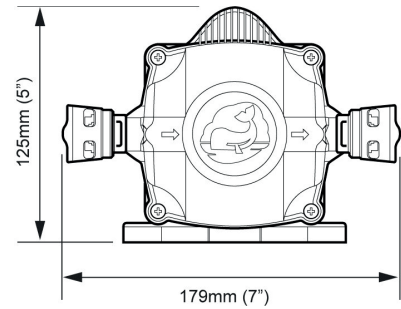

Dimensions

Specification				
Product Code	FW0814	FW1214	FW1215	FW1225
Open Flow Rate (per min)	8 ltrs (2.0 US GPM)		11.5 ltrs (3.0 US GPM)	
Number of Outlets	1 - 2 outlets		3 - 4 outlets	
Voltage	12 V d.c.			24 V d.c.
Max. System Pressure	2 bar (30 psi)		3 bar (45 psi)	
Hose Connections	Whale® Quick Connect 15mm Female Connections 2 x 1/2" Threaded Connectors and 2 x 1/2" Barbed Connectors included			
Recommended Fuse Size	5 Amp Automotive	7.5 Amp Automotive	7.5 Amp Automotive	5 Amp Automotive
Current Draw	4 amps	6 amps	6 amps	3.5 amps
Weight	1.5 kg (3.3 lbs)			