



# INSTALLATION INSTRUCTIONS

## Model 125 DOMINATOR

Your choice of a Wolo horn is a perfect choice to compliment your vessel or vehicle. Wolo horn's are manufactured with the finest quality materials and every horn is inspected and tested before being packaged. Precision workmanship and quality components will assure years of dependable service.

### MOUNTING

1. Locate the desired area you wish to mount the Dominator Horn. For best results, the front of the horn should be unobstructed so that the horn's sound can project straight ahead. Use the horn's gasket as a template, mark hole locations and drill to size. (See Fig. A.)

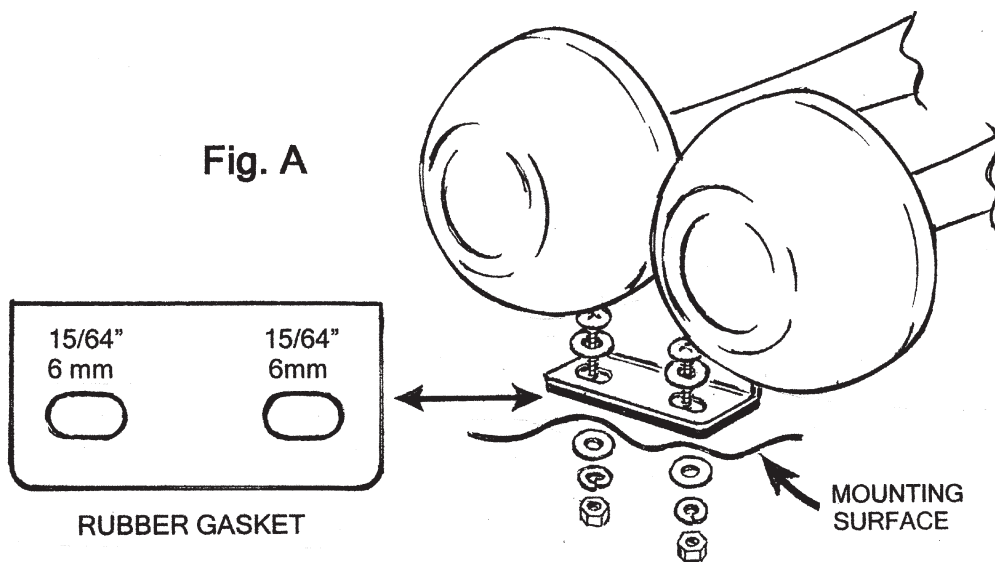

2. Mark the wire hole location if the horn's wire is going to pass through the mounting surface and drill to size. (See Fig. C)

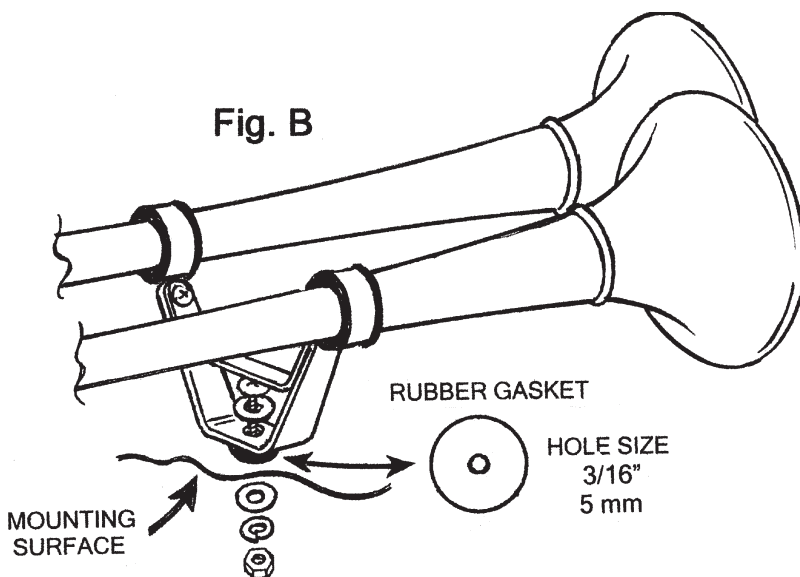

**IMPORTANT:** Make sure the hole is free of any burrs that could cut into the horn's wire. For roof mount mounting, to prevent water leaks, it is recommended that silicon or a waterproof sealer be placed on the wire at the point of entry into the roof.

3. Secure the horn using the hardware provided. Tighten screws evenly to prevent damage to the horn. (See Fig. A.) **IMPORTANT:** Be sure to use the rubber gasket to protect against water leaks.
4. Push the front bracket forward until it is tight. Use the bracket as a template, mark hole location and drill to size. (See Fig. B).
5. Secure the front trumpet bracket to the location using the hardware provided. Tighten screw evenly. **IMPORTANT:** Be sure to use the rubber gasket to protect against water leaks.

# WIRING

## WIRING to New Horn Button Switch (See Fig. C)

6. Connect one wire from each horn to (+) 12-volts positive, the battery, alternator, etc. A 8 amp inline fuse should be used (not included.)
7. Connect the horn switch (not provided) to the other black wire of each horn.
8. Connect the horn switch's other wire to ground, under any metal bolt that is clean of paint and rust.

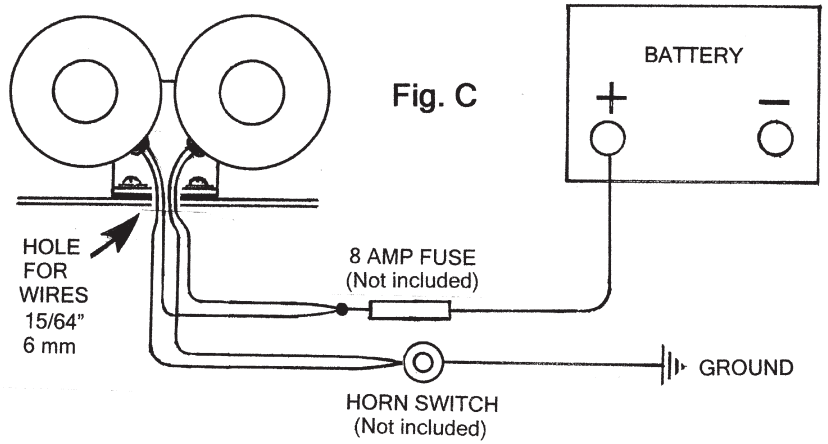

## WIRING to Factory Horn System With Two (2) Wires (See Fig. D)

9. If the factory horn has two wire terminals, remove the wires from the factory horn and connect one wire to each of The Dominator horns. Installation is complete.

## WIRING to Factory Horn System With One (1) Wire (See Fig. E)

10. If the factory horn has one wire terminal, remove the wire from the factory horn and connect to one wire of each of The Dominator horns.
11. The other horn wire from each of The Dominator horns is connected to ground, under any metal bolt that is clean of paint and rust. Installation is complete.

**IMPORTANT: Make sure all wires are secured and connections are properly taped.**

