

⚠️ DANGER

HAZARD OF FIRE, ELECTRIC SHOCK, EXPLOSION, OR ARC FLASH

This Guide is in addition to, and incorporates by reference, the relevant product manuals for each product in the Freedom XC/X series. Before reviewing this guide you must read the relevant product manuals. Unless specified, information on safety, specifications, installation, and operation is as shown in the primary documentation received with the product. Ensure you are familiar with that information before proceeding.

Failure to follow these instructions will result in death or serious injury.

1

⚠️ DANGER
HAZARD OF FIRE, ELECTRIC SHOCK, EXPLOSION, OR ARC FLASH

- Use of an accessory not recommended or sold by the manufacturer may result in a risk of fire, electric shock, or injury to persons.
- Disconnect all DC and AC sources that are powering the Freedom series inverter and any connected equipment before installing the GFCI device.
- Do not tamper with the connectors provided with the cables on the inverter and the GFCI device.
- Do not damage the connector or cables when cutting the cable tie.
- Do not install the GFCI device with a damaged connector or cables.
- Replace the cover plate before operating, if the GFCI device is not installed.

Failure to follow these instructions will result in death or serious injury.

2

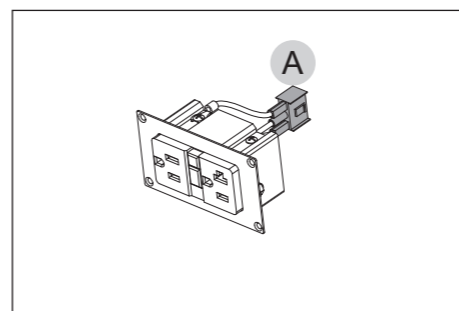

Take the GFCI device out of its box. It comes with an attached connector **A**. You will need the following tools.

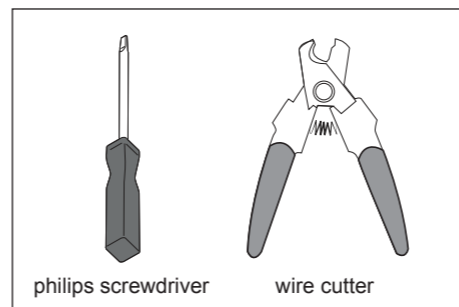

3

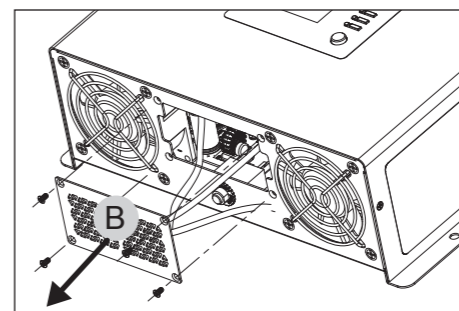

Remove the four screws and detach the GFCI cover plate **B** from the inverter unit. Set aside the screws.

4

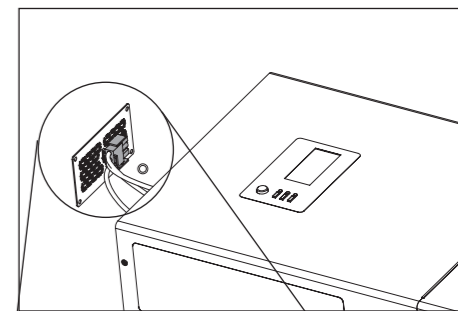

Cut the cable tie holding the unit's GFCI connector **C** to the GFCI cover plate **B**.

5

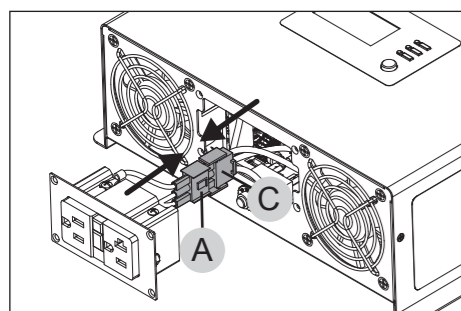

Attach the two connectors together **A** → **C**.

6

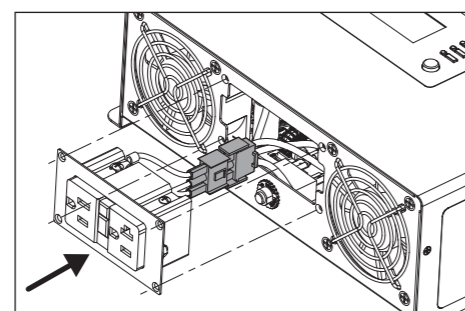

Mount the GFCI device onto the inverter unit.

7

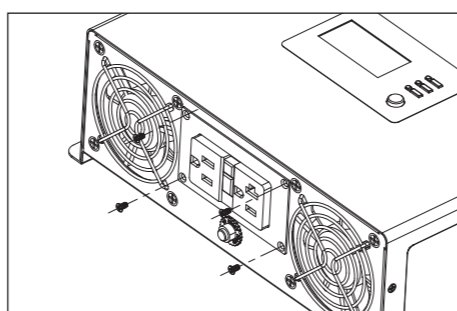

Secure the GFCI device to the inverter unit with the four screws from step 3.

Avoid damaging the screw heads when fastening. Do not over-tighten.

8

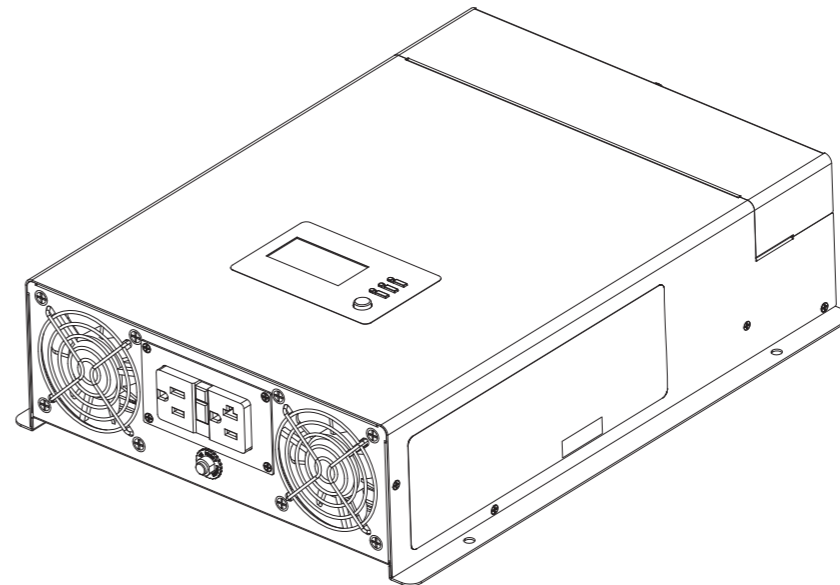

Freedom XC unit with the GFCI device installed.

